

# CATALOGO GENERALE '18/19





**TUSCANIA**  
ceramiche

Stile di vita italiano.  
*Invidiato ed imitato in tutto il mondo.  
Stile e Design, un'eccellenza da sempre riconosciuta  
al nostro paese, che detiene la leadership creativa e  
qualitativa anche nel mondo ceramico.*

---

Italian lifestyle.  
*Envied and copied around the world.  
Italy has always been recognised for its excellence  
in style and design, and as a leader in creativity  
and quality, also in the world of ceramics.*

Style de vie italien.  
*Envie et imité dans le monde entier.  
Style et design, une excellence reconnue dans notre pays qui se place aux  
premiers rangs de la créativité  
et de la qualité, y compris dans l'univers céramique.*

Italienischer Lebensstil.  
*Weltweit beneidet und imitiert.  
Stil und Design, hervorragende Eigenschaften,  
die unserem Land schon immer anerkannt wurden, das die kreative und  
qualitative Leadership auch  
in der Welt der Keramik in den Händen hält.*



Indice  
Index  
Index  
Inhaltsverzeichnis

agadir	124	manhattan <b>NEW</b>	410
atelier <b>NEW</b>	46	meteora <b>NEW</b>	24
atelier FP2 <b>NEW</b>	338	meteora FP2 <b>NEW</b>	348
athena <b>NEW</b>	202	mini mosaico	418
bark	288	my s'tile <b>NEW</b>	38
basic	112	my s'tile FP2 <b>NEW</b>	340
beton floor easy collection <b>NEW</b>	320	modern easy collection	322
beton wall <b>NEW</b>	390	navajo	264
bricks	196	nido d'ape	418
camelot	298	north wind floor	254
carociment	120	north wind wall	378
chalet	284	north wind FP2	368
cor-stone	160	piasentina	216
cor-stone FP2	354	pierre bleue	144
cruz easy collection <b>NEW</b>	328	pierre bleue FP2	352
crystal easy collection	324	quarzo	192
decapé floor	222	rall	334
decapé wall <b>NEW</b>	374	re-wood	230
decapé FP2	364	sardegna 20x20	402
dhoga	292	scratch	76
durango	164	shine	62
durango FP2	356	shiny marble <b>NEW</b>	398
edelweiss	170	sparkly	188
edelweiss FP2	358	sparkly FP2	362
eternity	116	stardust <b>NEW</b>	210
etruria	174	technika	84
feel <b>NEW</b>	54	technika FP2	344
fjord	246	terraforte	182
fjord FP2	366	terraforte FP2	360
grey soul	90	terre toscane	306
grey soul FP2	346	thunderwood	270
gushure <b>NEW</b>	242	thunderwood FP2	370
kouros	280	tomahawk <b>NEW</b>	152
industrial	332	trame	98
jamaica	394	trevi easy collection	326
le leghe	14	tribeca <b>NEW</b>	136
level floor	68	unico	236
level wall	382	victoria	386
limestone <b>NEW</b>	130	woody floor	276
limestone FP2 <b>NEW</b>	342		

lettura del catalogo reading the catalogue la lecture du catalogue benützung des kataloges	4
floor: indice per formato format index index des formats formateverzeichnis	6
floor: indice cromatico chromatic index index chromatique chromatischer index	8
wall: indice per formato format index index des formats formateverzeichnis	373
simbologia caratteristiche tecniche symboles technical characteristics symboles des caracteristiques techniques symbole technischen eigenschaften	428
consigli di posa laying recommendations conseils de pose ratschläge für die verlegung	437
consigli per la stuccatura e la pulizia dopo posa recommendations for grouting and cleaning after installation conseils pour le stucage et le nettoyage après la pose ratschläge für die verfugung und erste reinigung nach der verlegung	439
pulizia e manutenzione dei prodotti Tuscania cleaning and care of Tuscania products nettoyage et entretien des articles Tuscania reinigung und pflege der produkte von Tuscania	442
avvertenze warning instructions instructions hinweise	450
coefficiente di attrito (scivolosità) coefficient of friction (slipperiness) coefficient de frottement (antidérapant) rutschfestigkeit	451
listello coprispigolo edge-protection batten baguette d'angle randabdeckleiste	452
certificazioni certifications certifications zertifizierungen	453
legenda legend légend zeichenerklärung	453
condizioni generali di vendita general conditions of sale conditions générales de vente allgemeine verkaufsbedingungen	454
tabella pesi ed imballi sizes weight and packaging mesures poids et emballages tabelle der gewichte und verpackungen	456

Indice sezioni  
Section index  
Index sections  
Inhaltsverzeichnis abschnitte

effetto metallo metal-look . effet métallique . metalloptik	12	effetto cotto cotto-look . effet cotto . cottooptik	296
le leghe	14	camelot	298
		terre toscane	306
effetto cemento concrete-look . effet ciment . zementoptik	22	easy collection	318
agadir	124	beton floor easy collection <b>NEW</b>	320
atelier <b>NEW</b>	46	cruz easy collection <b>NEW</b>	328
basic	112	crystal easy collection	324
carociment	120	modern easy collection	322
eternity	116	trevi easy collection	326
feel <b>NEW</b>	54	technical project	330
grey soul	90	atelier FP2 <b>NEW</b>	338
level floor	68	cor-stone FP2	354
meteora <b>NEW</b>	24	decapé FP2	364
my s'tile <b>NEW</b>	38	durango FP2	356
scratch	76	edelweiss FP2	358
shine	62	fjord FP2	366
technika	84	grey soul FP2	346
trame	98	industrial	332
effetto pietra stone-look . effet pierre . steinoptik	128	limestone FP2 <b>NEW</b>	342
bricks	196	meteora FP2 <b>NEW</b>	348
cor-stone	160	my s'tile FP2 <b>NEW</b>	340
durango	164	north wind FP2	368
edelweiss	170	pierre bleue FP2	352
etruria	174	rall	334
limestone <b>NEW</b>	130	sparkly FP2	362
pierre bleue	144	technika FP2	344
quarzo	192	terraforte FP2	360
sparkly	188	thunderwood FP2	370
terraforte	182		
tomahawk <b>NEW</b>	152	rivestimenti	372
tribeca <b>NEW</b>	136	wall tiles . faiences . wandfliesen	
effetto marmo marble-look . effet marbre . marmooptik	200	beton wall <b>NEW</b>	390
athena <b>NEW</b>	202	decapé wall <b>NEW</b>	374
piasentina	216	jamaica	394
stardust <b>NEW</b>	210	level wall	382
effetto legno wood-look . effet bois . holzoptik	220	manhattan	410
bark	288	mini mosaico	418
chalet	284	nido d'ape	418
decapé floor	222	north wind wall	378
dhoga	292	sardegna 20x20	402
fjord	246	shiny marble <b>NEW</b>	398
gushure <b>NEW</b>	242	victoria	386
kouros	280		
navajo	264		
north wind floor	254		
re-wood	230		
thunderwood	270		
unico	236		
woody floor	276		

lettura del catalogo

reading the catalogue . la lecture du catalogue . benützung des kataloges

# 1 LE LEGHE

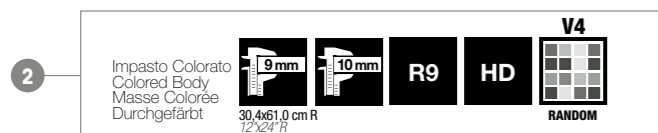

3 **R** Rettificato - Rectified

4 platino



11	L7S9	122,6x122,6 cm 48"x48"	R	00,00*
	L8S7	80x160 cm 31"x62"	R	00,00*
	J2S2	61,3x122,6 cm 24"x48"	R	00,00*
	J1S7	61,0x61,0 cm 24"x24"	R	00,00*
	L7S8	61,0x61,0 cm 24"x24" OUTDOOR	R	00,00*
	J9S4	30,4x61,0 cm 12"x24"	R	00,00*

7 decori - decors - décors - dekors  
mosaico monocolore 81 tessere 3x3 \* 00,00/PZ e/o \* 00,00/MQ  
30x30 cm 12"x12"

4 platino



5 pezzi speciali - special pieces - pièces spéciales - formteile



5  
4 platino  
7 battiscopa **R** \* 0,00/PZ  
6,5x61,0 cm R 2 1/2"x24" R  
4 platino

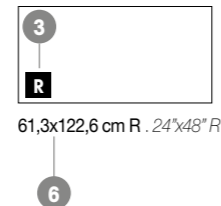

- 1 Nome serie  
Series name  
Nom série  
Serienbezeichnung
- 2 Caratteristiche tecniche  
Technical characteristics  
Caractéristiques techniques  
Technische daten
- 3 Finitura  
Product types  
Finition produit  
Ausführung des Produkts
- 4 Colore  
Colour  
Couleur  
Farbe
- 5 Tacche colore  
Colour samples  
Couleurs disponibles  
Farbmuster
- 6 Formati  
Sizes  
Formats  
Formate
- 7 Descrizione articolo  
Product types  
Description de l'article  
Beschreibung des artikel
- 8 Prezzo/ € Mq  
Price/ € Sq.Mt.  
Prix/ € Mq  
Preis/ € Qm
- 9 Pz/scatola  
Pieces/box  
Pièces/bôte  
Stücke/karton
- 10 Prezzo/ € Pz  
Price/ € Pieces  
Prix/ € Pièces  
Preis/ € Stücke
- 11 Codice web per disponibilità articolo  
Web code for article availability.  
Code Web pour disponibilité de l'article.  
Webcode für Artikelverfügbarkeit.

\* I prezzi potrebbero subire variazioni che verranno prontamente comunicate.  
Prices may be subject to variations that will be promptly communicated.  
Les prix pourront subir des variations que nous Vous communiquerons sans faute.  
Die Preise können weitere änderungen haben, werden umgehend mitgeteilt.

# floor

## signs of style

Tuscania: i pavimenti

*Numerose linee di pavimenti e con differenti caratteristiche tecniche ed estetiche per soddisfare le diverse esigenze di gusto e di stile.*

*Una ricca varietà di prodotti per interno ed esterno adatti ad interpretare la modernità per utilizzi diversi, il privato e il pubblico, la nuova architettura ed il recupero conservativo.*

Tuscania: floor tiles

*A wide range of floors-coverings with different technical and aesthetic characteristics to satisfy diverse needs for taste and style.*

*A full line of products for interiors and exteriors that interprets modernity for different uses, private and public, new architecture and conservative restoration.*

Tuscania et le monde des sols

*De nombreuses lignes pour l'aménagement des sols avec différentes caractéristiques techniques et esthétiques afin de satisfaire les goûts et les styles les plus éclectiques.*

*Une gamme riche en produits pour l'intérieur et l'extérieur adéquats pour interpréter les désirs de modernité dans des utilisations diverses, le privé, le public, la nouvelle architecture et la restauration conservative.*

Tuscania die Fußböden

*Zahlreiche Linien für Fußböden mit unterschiedlichen technischen und ästhetischen Eigenschaften, um den verschiedensten Design- und Stilanforderungen gerecht zu werden.*

*Eine reiche Auswahl an Produkten für Innen- u. Aussenbereiche, geeignet um die Moderne Architektur, im privaten sowie öffentlichen Bereichen, zu interpretieren.*

**T**  
**TUSCANIA**  
ceramiche



Grey

TRAME JUTA GRIGIO pag. 98	METEORA GRIGIO pag. 24	CRUZ GRIGIO pag. 328	LE LEGHE PLATINO pag. 14	FEEL ASH pag. 54
ATELIER BRUN pag. 46	GREY SOUL DARK pag. 90	BASIC COLD pag. 112	DHOGA GRIGIO pag. 292	TRIBECA GREY pag. 136
METEORA MIX pag. 24	INDUSTRIAL GRIGIO pag. 332	GREY SOUL MID pag. 90	TERRAFORTE CENERE pag. 182	ATELIER GRIS pag. 46
MY S'TILE GREY pag. 38	NAVAJO GREY pag. 264	ETRURIA GRIGIO pag. 174	CHALET GREY pag. 284	TOMAHAWK GREY pag. 000
SHINE GREY pag. 62	RE-WOOD GREY pag. 230	STARDUST GREY pag. 210	FJORD GRA pag. 246	PIERRE BLEUE CLAIR pag. 144
NAVAJO MELANGE pag. 264	UNICO CENERE pag. 236	FEEL LIGHT pag. 54	MODERN GREY pag. 322	DURANGO GREY pag. 164
LIMESTONE ASH pag. 130	DECAPÉ GRIGIO pag. 222	CRYSTAL GRIGIO pag. 324	SCRATCH GREY pag. 76	LEVEL GREY pag. 68
COR-STONE GREY pag. 160	KOUROS GREY pag. 280	WOODY FLOOR GRIGIO pag. 276	ETERNITY pag. 116	CAROCIMENT GRIS pag. 120
QUARZO GRIGIO pag. 192	FEEL GREY pag. 54	GREY SOUL LIGHT pag. 90	TECHNIKA GRIGIO pag. 84	PIASENTINA LIGHT GREY pag. 216
ETRURIA CENERE pag. 174	TERRAFORTE GRIGIO pag. 182	LE LEGHE STAGNO pag. 14	NORTH WIND GREY pag. 254	RALL GRIGIO pag. 334
BARK GRIGIO pag. 288	EDELWEISS GREY pag. 170	BRICKS GREY pag. 196	ATHENA GRIGIO pag. 202	
	BETON GRIS pag. 320			
	PIERRE BLEUE GLACE pag. 144			

Black - Anthracite

DHOGA NERO pag. 292	LE LEGHE NIELLO pag. 14
PIERRE BLEUE FONCÉ pag. 144	PIERRE BLEUE ANTIQUE pag. 144
PIASENTINA DARK GREY pag. 216	LEVEL ANTHRACITE pag. 68
FEEL DARK pag. 54	SHINE ANTHRACITE pag. 62
TRIBECA DARK GREY pag. 136	EDELWEISS COAL pag. 170
LIMESTONE COAL pag. 130	MODERN BLACK pag. 322
COR-STONE DARK pag. 160	TOMAHAWK CHARCOAL pag. 152
TECHNIKA ANTHRACITE pag. 84	
LEVEL DARK GREY pag. 68	
ATHENA NERO pag. 202	

Blue - Green

LE LEGHE COBALTO pag. 14
TOMAHAWK BLUE pag. 152
UNICO INDACO pag. 236
GUSHURE LIGHT NAVY pag. 242
RALL AZZURRO pag. 334
RALL GIADA pag. 334

White

RE-WOOD WHITE pag. 230	TERRAFORTE BIANCO pag. 182
TRIBECA WHITE pag. 136	SHINE WHITE pag. 62
MY S'TILE WHITE pag. 38	TECHNIKA BIANCO pag. 84
EDELWEISS WHITE pag. 170	CHALET WHITE pag. 284
STARDUST WHITE pag. 210	DECAPÉ BIANCO pag. 222
TRAME JUTA BIANCO pag. 98	KOUROS WHITE pag. 280
BRICKS WHITE pag. 196	BARK BIANCO pag. 288
ATHENA BIANCO pag. 202	ATELIER BLANC pag. 46
SCRATCH WHITE pag. 76	DHOGA BIANCO pag. 292
LEVEL WHITE pag. 68	BETON BLANC pag. 320
PIASENTINA WHITE pag. 216	LIMESTONE ICE pag. 130
RALL NEVE pag. 334	METEORA BIANCO pag. 24
AGADIR BIANCO pag. 124	GREY SOUL WHITE pag. 90
	TOMAHAWK WHITE pag. 152

Beige

<b>WOODY FLOOR NOCE</b> pag. 276	<b>MY S'TILE CAMEL</b> pag. 38	<b>TECHNIKA TAUPE</b> pag. 84	<b>GUSHURE NUT</b> pag. 242	<b>MY S'TILE SAND</b> pag. 38
<b>FJORD HONNING</b> pag. 246	<b>ATELIER GREIGE</b> pag. 46	<b>SCRATCH TAUPE</b> pag. 76	<b>INDUSTRIAL PANNA</b> pag. 332	<b>GREY SOUL SAND</b> pag. 90
<b>CHALET SAND</b> pag. 284	<b>UNICO BEIGE</b> pag. 236	<b>SHINE SAND</b> pag. 62	<b>QUARZO BEIGE</b> pag. 192	<b>TRIBECA BEIGE</b> pag. 136
<b>NAVAJO BROWN</b> pag. 264	<b>INDUSTRIAL BEIGE</b> pag. 332	<b>SCRATCH CREAM</b> pag. 76	<b>DURANGO MEDIUM</b> pag. 164	<b>EDELWEISS BEIGE</b> pag. 170
<b>DURANGO WALNUT</b> pag. 164	<b>BETON MARRON</b> pag. 320	<b>BASIC WARM</b> pag. 112	<b>TERRAFORTE DORATO</b> pag. 182	<b>FEEL ALMOND</b> pag. 54
<b>DECAPÉ MIELE</b> pag. 222	<b>NAVAJO SAND</b> pag. 264	<b>METEORA BEIGE</b> pag. 24	<b>ETRURIA BEIGE</b> pag. 174	<b>CRYSTAL BEIGE</b> pag. 324
<b>CRUZ BEIGE</b> pag. 328	<b>LIMESTONE BEIGE</b> pag. 130	<b>PIASENTINA MARFIL</b> pag. 216	<b>BARK BEIGE</b> pag. 288	<b>TREVI BEIGE</b> pag. 326
<b>NORTH WIND OAK</b> pag. 254	<b>WOODY FLOOR BEIGE</b> pag. 276	<b>RALL BEIGE</b> pag. 334	<b>RALL GIALLO</b> pag. 334	<b>ATHENA ALMOND</b> pag. 202
<b>STARDUST ALMOND</b> pag. 210	<b>TECHNIKA BEIGE</b> pag. 84			<b>TREVI ALMOND</b> pag. 326
<b>CRUZ CREMA</b> pag. 328	<b>STARDUST WALNUT</b> pag. 210			
	<b>BETON TAUPE</b> pag. 320			
	<b>MODERN BEIGE</b> pag. 322			
	<b>CAROCIMENT BEIGE</b> pag. 120			

Red

<b>THUNDERWOOD FIERYCHERRY</b> pag. 270
<b>LE LEGHE BRONZO</b> pag. 14
<b>METEORA COTTO</b> pag. 24
<b>CAMELOT COTTO</b> pag. 298
<b>TERRE TOSCANE VOLTERRA</b> pag. 306
<b>TERRAFORTE CUOIO</b> pag. 182
<b>CAMELOT TRAMONTO</b> pag. 298
<b>RALL ARANCIO</b> pag. 334
<b>TERRE TOSCANE SAN GIMIGNANO</b> pag. 306
<b>BRICKS CLASSIC</b> pag. 196
<b>TERRE TOSCANE VINCI</b> pag. 306
<b>CAMELOT BEIGE</b> pag. 298
<b>RALL ROSATO</b> pag. 334

Brown

<b>RE-WOOD MORO</b> pag. 230	<b>DECAPÉ MORO</b> pag. 222	<b>KOUROS BROWN</b> pag. 280
<b>NORTH WIND MELANGE</b> pag. 254	<b>KOUROS SAND</b> pag. 280	<b>THUNDERWOOD THUNDERSTRUCK</b> pag. 270
<b>ETRURIA COTTO</b> pag. 174	<b>DECAPÉ NOCE</b> pag. 222	<b>NORTH WIND BROWN</b> pag. 254
<b>TERRE TOSCANE MONTALCINO</b> pag. 306	<b>TERRAFORTE TORTORA</b> pag. 182	<b>BARK NOCE</b> pag. 288
<b>TERRAFORTE RUGGINE</b> pag. 182		<b>FJORD BRUN</b> pag. 246
<b>SPARKLY RUGGINE</b> pag. 188		<b>CHALET BROWN</b> pag. 284
<b>DHOGA SABBIA</b> pag. 292		

Ivory

<b>UNICO AVORIO</b> pag. 236
<b>WOODY FLOOR AVORIO</b> pag. 276
<b>FJORD VIT</b> pag. 246
<b>DURANGO WASHED</b> pag. 164
<b>THUNDERWOOD SANDSTORM</b> pag. 270
<b>GUSHURE BONE</b> pag. 242
<b>NORTH WIND IVORY</b> pag. 254

effetto metallo  
metal-look . effet métallique . metalloptik



Le leghe | 14

*Grès porcellanato*  
*Porcelain stoneware*  
*Grès cérame coloré*  
*Feinsteinzeug*



# LE LEGHE

---

*Grès porcellanato impasto colorato*

*Color body porcelain stoneware . Grès cérame coloré dans la masse . Durchgefärbtes feinsteinzeug*

*effetto metallo  
metal-look  
effet métallique  
metalloptik*



*Questo progetto è ispirato al magico gioco cromatico dei metalli e dalle loro infinite sfumature sottolineate e generate da sorprendenti effetti luminosi.*

*Cinque finiture cromatiche, accuratamente selezionate per potenziare la bellezza del materiale ceramico.*

---

*This project is inspired by the magical colour effects of metal and its infinite nuances enriched and illuminated by beautiful light effects.*

*Five colour finishes, carefully selected to enhance the beauty of ceramic.*

---

*Ce projet s'inspire du merveilleux jeu chromatique des métaux et de leurs innombrables nuances sublimées et produites par de surprenants effets lumineux.*

*Cinq finitions chromatiques, soigneusement sélectionnées pour intensifier la beauté du matériau céramique.*

---

*Dieses Projekt inspiriert sich an dem magischen Farbspiel der Metalle und ihrer unendlichen unterstrichenen Nuancen, die von überraschenden Leuchteffekten erzeugt werden.*

*Fünf Farbangebote, die sorgfältig ausgewählt wurden, um die Schönheit der Keramik zu verstärken.*





floor: NIELLO | 61,0x61,0 cm R\_24"x24" R  
wall: STAGNO | 61,3x122,6 cm R\_24"x48" R

# LE LEGHE

Impasto Colorato  
Colored Body  
Masse Colorée  
Durchgefärbt



R9

R11

HD

outdoor

V3

HIGH

**R** Rettificato  
Rectified



\*122,6x122,6 cm R .  
48"x48" R  
\*stagno, platino



80x160 cm R . 31"x62" R



61,3x122,6 cm R . 24"x48" R

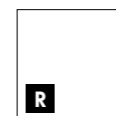

61,0x61,0 cm R . 24"x24" R  
\*61,0x61,0 cm R - outdoor .  
24"x24" R - outdoor  
\*stagno, platino



30,4x61,0 cm R . 12"x24" R

## LE LEGHE

Per la disponibilità articolo: [www.tuscaniagres.it](http://www.tuscaniagres.it)  
digitando il codice web segnalato a lato dei formati.  
For the item's availability: [www.tuscaniagres.it](http://www.tuscaniagres.it)  
type the web code reported next to the sizes.  
Pour vérifier la disponibilité de l'article: [www.tuscaniagres.it](http://www.tuscaniagres.it)  
en saisissant le code web indiqué à coté des formats.  
Für die Artikelverfügbarkeit: [www.tuscaniagres.it](http://www.tuscaniagres.it)  
web code eingeben, an der Seite von Formaten angedeutet.

## stagno



L8S0	122,6x122,6 cm 48"x48"	R	54,02
L8S5	80x160 cm 31"x62"	R	52,47
J2S0	61,3x122,6 cm 24"x48"	R	44,75
J1S5	61,0x61,0 cm 24"x24"	R	37,04
L7S7	61,0x61,0 cm 24"x24" OUTDOOR	R	38,58
J9S1	30,4x61,0 cm 12"x24"	R	33,95

## cobalto



L8S6	80x160 cm 31"x62"	R	52,47
J2S1	61,3x122,6 cm 24"x48"	R	44,75
J1S6	61,0x61,0 cm 24"x24"	R	37,04
J9S2	30,4x61,0 cm 12"x24"	R	33,95

## platino



L7S9	122,6x122,6 cm 48"x48"	R	54,02
L8S7	80x160 cm 31"x62"	R	52,47
J2S2	61,3x122,6 cm 24"x48"	R	44,75
J1S7	61,0x61,0 cm 24"x24"	R	37,04
L7S8	61,0x61,0 cm 24"x24" OUTDOOR	R	38,58
J9S4	30,4x61,0 cm 12"x24"	R	33,95

## niello



L8S8	80x160 cm 31"x62"	R	52,47
J2S3	61,3x122,6 cm 24"x48"	R	44,75
J1S8	61,0x61,0 cm 24"x24"	R	37,04
J9S5	30,4x61,0 cm 12"x24"	R	33,95

## bronzo



L8S4	80x160 cm 31"x62"	R	52,47
J2S4	61,3x122,6 cm 24"x48"	R	44,75
J1S9	61,0x61,0 cm 24"x24"	R	37,04
J9S3	30,4x61,0 cm 12"x24"	R	33,95

# LE LEGHE

LE LEGHE

decori - decors - décors - dekors

mosaico monocolore 81 tessere 3x3 - 30x30 cm 12"x12"  13,27/PZ



mosaico asimmetrico 18 pz - 30x30 cm 12"x12"  13,27/PZ



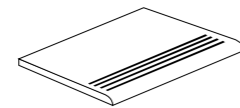

pezzi speciali - special pieces - pièces spéciales - formteile



step  
30,4x61,0 cm R 12"x24" R  15,45/PZ

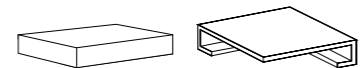

stagno  
cobalto  
platino  
niello  
bronzo



battiscopa   
6,5x122,6 cm R 2 1/2"x48" R  9,26/PZ

vista frontale  
angolare costa retta dx/sx  
30,5x122,6x4 cm 12"x48"x1 3/4"  
34x34x4 cm 13"x13"x1 3/4"

vista dal retro

 200,62/PZ  
 103,40/PZ

stagno  
cobalto  
platino  
niello  
bronzo

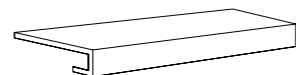

gradino costa retta   
30,5x122,6x4 cm 12"x48"x1 3/4"  
34x61,0x4 cm 13"x24"x1 3/4"

 163,58/PZ  
 83,33/PZ

stagno  
cobalto  
platino  
niello  
bronzo

Note - Notes - Notes - Anmerkungen

I battiscopa vengono venduti a pz. e a scatola completa. Tutti gli altri pezzi speciali vengono venduti al pezzo. I gradini vengono prodotti solo su ordinazione (tempo minimo di consegna 20 gg lavorativi).  
Skirtings are sold by piece and full boxes. All other special trims are sold by piece. Steps are produced only on request (minimum delivery terms of 20 days).  
Les plinthes sont vendues la pièce et par boîte complète. Les autres pièces spéciales sont vendus la pièce. Le plat de marche sont produit sur demande (délai minimum de 20 jours).  
Die Sockelleisten werden pro Stk. und Vollen Kartons verkauft. Stufen und Stufenecken werden nur auf Bestellung produziert (Lieferzeiten mindesten 20 arbeitstagen ab Auftragserteilung).

indoor: PLATINO | 61,0x61,0 cm R\_24"x24" R  
outdoor: TERRAFORTE CENERE FP2 | 61,5x61,5 cm NS/BD\_24"x24" NS/BD



effetto cemento  
concrete-look . effet ciment . zementoptik



Agadir	124
Atelier	46
Basic	112
Carociment	120
Eternity	116
Feel	54
Grey Soul	90
Level Floor	68
Meteora	24
My S'tile	38
Scratch	76
Shine	62
Technika	84
Trame	98

*Grès porcellanato*  
*Porcelain stoneware*  
*Grès cérame coloré*  
*Feinsteinzeug*

  
**TUSCANIA**  
ceramiche

# METEORA

---

*Grès porcellanato impasto colorato*

*Color body porcelain stoneware . Grès cérame coloré dans la masse . Durchgefärbtes Feinsteinzeug*

*effetto cemento  
concrete-look  
effet ciment  
zementoptik*



*Una linea di alto impatto estetico,  
risultato di un ricercato progetto basato su una tecnologia  
d'avanguardia specifica per gli alti spessori.*

*La materia ceramica si modifica e si evolve secondo schemi tradizionali  
che hanno come termine di paragone la pietra naturale.*

---

*A captivating line resulting from a detailed project based  
on cutting-edge technology specific for high thicknesses.*

*The ceramic material changes and evolves according  
to traditional schemes inspired by natural stone.*

*Une ligne esthétiquement très impactante, issue d'un projet complexe basé  
sur une technologie de pointe, spécifique pour les épaisseurs majorées.*

*La matière céramique change et évolue selon des schémas  
traditionnels inspirés de la pierre naturelle.*

*Eine Serie mit einem hohen ästhetischen Eindruck, Ergebnis eines  
erlesenen Projekts, das sich auf eine spezifische fortschrittliche  
Technologie für hohe Stärken stützt.*

*Die Materie Keramik ändert und entwickelt sich gemäß  
traditionellen Schemen, die als Inspiration Naturstein nutzen.*











# METEORA

Impasto Colorato  
Colored Body  
Masse Colorée  
Durchgefärbt

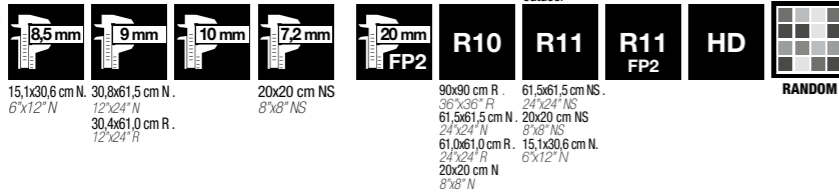

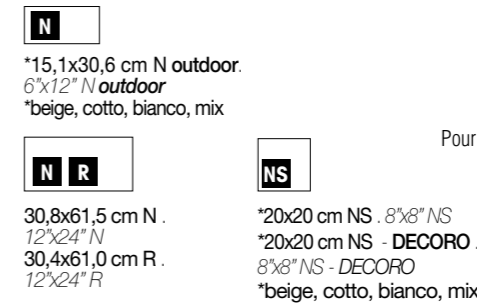
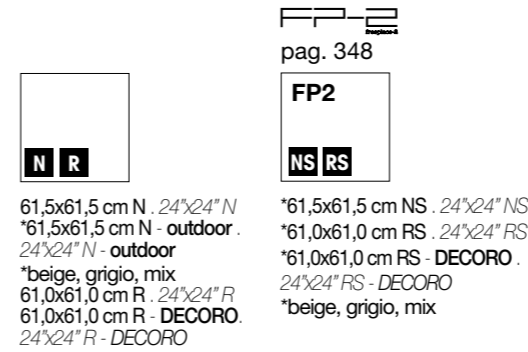
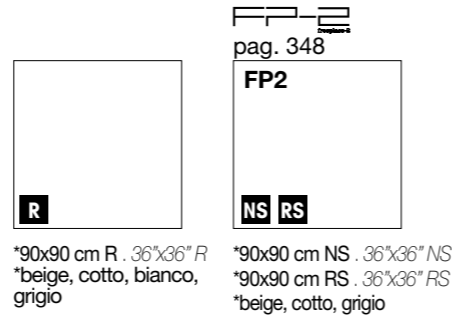

**N** Naturale Natural  
**NS** Naturale/Strutturato Natural/Textured  
**R** Rettificato Rectified  
**RS** Rettificato/Strutturato Rectified/Textured



**METEORA**  
Per la disponibilità articolo: [www.tuscaniagres.it](http://www.tuscaniagres.it)  
digitando il codice web segnalato a lato dei formati.  
For the item's availability: [www.tuscaniagres.it](http://www.tuscaniagres.it)  
type the web code reported next to the sizes.  
Pour vérifier la disponibilité de l'article: [www.tuscaniagres.it](http://www.tuscaniagres.it)  
en saisissant le code web indiqué à côté des formats.  
Für die Artikelverfügbarkeit: [www.tuscaniagres.it](http://www.tuscaniagres.it)  
web code eingeben, an der Seite von Formaten angedeutet.

## beige

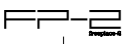

L4T1	90x90 cm 36"x36"	R	44,75
L2T5	61,5x61,5 cm 24"x24"	N	29,32
L3T9	61,5x61,5 cm 24"x24" OUTDOOR	N	30,86
L3T0	61,0x61,0 cm 24"x24"	R	37,04
L3T3	61,0x61,0 cm 24"x24" DECORO	R	60,49
L9W0	30,8x61,5 cm 12"x24"	N	24,69
L9W5	30,4x61,0 cm 12"x24"	R	33,95
L0U6	20x20 cm 8"x8" 	NS	24,07
L0U2	20x20 cm 8"x8"  DECORO	NS	27,78
L1U1	15,1x30,6 cm 6"x12" OUTDOOR	N	25,62
			
L5T9	90x90 cm 36"x36" FP2	NS	61,73
L5T4	90x90 cm 36"x36" FP2	RS	74,08
L6T2	61,5x61,5 cm 24"x24" FP2	NS	55,56
L6T5	61,0x61,0 cm 24"x24" FP2	RS	67,90
L7W2	61,0x61,0 cm 24"x24" DECORO FP2	RS	77,16



## cotto



L4T2	90x90 cm 36"x36"	R	44,75
L2T6	61,5x61,5 cm 24"x24"	N	29,32
L3T1	61,0x61,0 cm 24"x24"	R	37,04
L3T6	61,0x61,0 cm 24"x24" DECORO	R	60,49
L9W1	30,8x61,5 cm 12"x24"	N	24,69
L9W6	30,4x61,0 cm 12"x24"	R	33,95
L9T0	20x20 cm 8"x8" 	NS	24,07
L0U1	20x20 cm 8"x8"  DECORO	NS	27,78
L1U4	15,1x30,6 cm 6"x12" OUTDOOR	N	25,62
			
L6T0	90x90 cm 36"x36" FP2	NS	61,73
L5T5	90x90 cm 36"x36" FP2	RS	74,08

## bianco



L9X0	90x90 cm 36"x36"	R	44,75
L2T3	61,5x61,5 cm 24"x24"	N	29,32
L2T8	61,0x61,0 cm 24"x24"	R	37,04
L3T4	61,0x61,0 cm 24"x24" DECORO	R	60,49
L9W2	30,8x61,5 cm 12"x24"	N	24,69
L9W7	30,4x61,0 cm 12"x24"	R	33,95
J3R8	20x20 cm 8"x8" 	NS	24,07
L0U4	20x20 cm 8"x8"  DECORO	NS	27,78
L1U3	15,1x30,6 cm 6"x12" OUTDOOR	N	25,62

## grigio



L4T3	90x90 cm 36"x36"	R	44,75
L2T7	61,5x61,5 cm 24"x24"	N	29,32
L4T0	61,5x61,5 cm 24"x24" OUTDOOR	N	30,86
L4T2	61,0x61,0 cm 24"x24"	R	37,04
L3T7	61,0x61,0 cm 24"x24" DECORO	R	60,49
L9W3	30,8x61,5 cm 12"x24"	N	24,69
L9W8	30,4x61,0 cm 12"x24"	R	33,95
			
L5T7	90x90 cm 36"x36" FP2	NS	61,73
L5T6	90x90 cm 36"x36" FP2	RS	74,08
L6T3	61,5x61,5 cm 24"x24" FP2	NS	55,56
L0U7	61,0x61,0 cm 24"x24" FP2	RS	67,90
L7W3	61,0x61,0 cm 24"x24" DECORO FP2	RS	77,16

## mix



L2T4	61,5x61,5 cm 24"x24"	N	29,32
L3T8	61,5x61,5 cm 24"x24" OUTDOOR	N	30,86
L2T9	61,0x61,0 cm 24"x24"	R	37,04
L3T5	61,0x61,0 cm 24"x24" DECORO	R	60,49
L9W4	30,8x61,5 cm 12"x24"	N	24,69
L9W9	30,4x61,0 cm 12"x24"	R	33,95
L3R7	20x20 cm 8"x8" 	NS	24,07
L0U5	20x20 cm 8"x8"  DECORO	NS	27,78
L1U5	15,1x30,6 cm 6"x12" OUTDOOR	N	25,62
			
L6T1	61,5x61,5 cm 24"x24" FP2	NS	55,56
L6T4	61,0x61,0 cm 24"x24" FP2	RS	67,90
L7W4	61,0x61,0 cm 24"x24" DECORO FP2	RS	77,16

# METEORA

decori - decors - décors - dekors

decoro 61,0x61,0 cm 24"x24" **R** - 20x20 cm 8"x8" **NS** - 61,0x61,0 cm 24"x24" FP2 **RS**

20 soggetti diversi, miscelazione casuale. Disponibile in tutti i colori. - 20 assorted motifs, random mix. Available in all colours.

20 sujets différents, mélange aléatoire. Disponible dans toutes les gammes de couleur. - 20 verschiedene Motive, Zufallsmischung. In allen Farben verfügbar.

grigio



L3T7 | 61,0x61,0 cm 24"x24" **mix** **R**

FP2

L7W3 | 61,0x61,0 cm 24"x24" FP2 **mix** **RS**

# METEORA

decori - decors - décors - dekors

decoro 61,0x61,0 cm 24"x24" **R** - 20x20 cm 8"x8" **NS** - 61,0x61,0 cm 24"x24" FP2 **RS**

20 soggetti diversi, miscelazione casuale. Disponibile in tutti i colori. - 20 assorted motifs, random mix. Available in all colours.

20 sujets différents, mélange aléatoire. Disponible dans toutes les gammes de couleur. - 20 verschiedene Motive, Zufallsmischung. In allen Farben verfügbar.

beige



L3T3 | 61,0x61,0 cm 24"x24" **mix** **R**

L0U2 | 20x20 cm 8"x8" **7,2mm** **mix** **NS**

FP2

L7W2 | 61,0x61,0 cm 24"x24" FP2 **mix** **RS**

cotto



L3T6 | 61,0x61,0 cm 24"x24" **mix** **R**

L0U1 | 20x20 cm 8"x8" **7,2mm** **mix** **NS**

bianco



L3T4 | 61,0x61,0 cm 24"x24" **mix** **R**

L0U4 | 20x20 cm 8"x8" **7,2mm** **mix** **NS**

FP2

L7W3 | 61,0x61,0 cm 24"x24" FP2 **mix** **RS**

grigio



L3T7 | 61,0x61,0 cm 24"x24" **mix** **R**

FP2

L7W3 | 61,0x61,0 cm 24"x24" FP2 **mix** **RS**

mix



L3T5 | 61,0x61,0 cm 24"x24" **mix** **R**

L0U5 | 20x20 cm 8"x8" **7,2mm** **mix** **N**

FP2

L7W4 | 61,0x61,0 cm 24"x24" FP2 **mix** **RS**

# METEORA

decori - decors - décors - dekors

mosaico mix 81 tessere 3x3 - 30x30 cm 12"x12"  13,27/PZ

mix cold  
bianco/grigio/mix



mix warm  
bianco/beige/cotto



mosaico asimmetrico 18 pz - 30x30 cm 12"x12"  13,27/PZ

beige

cotto

bianco

grigio

mix



pezzi speciali - special pieces - pièces spéciales - formteile



beige



cotto





bianco



grigio



mix

battiscopa  
6,5x61,5 cm N 2 1/2"x24" N  4,78/PZ  
6,5x20 cm N 2 1/2"x8" N  2,31/PZ

beige

cotto

bianco

grigio

mix



beige



cotto



bianco



grigio



mix

elemento "L" monolitico outdoor  
15x30x4 cm 6"x12"x1 3/4"  10,80/PZ

beige

cotto

bianco

grigio

mix

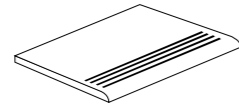

step  
30,8x61,5 cm 12"x24"  15,45/PZ

beige

cotto

bianco

grigio

mix

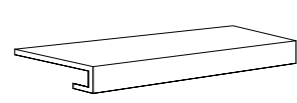

gradino costa retta  83,33/PZ  
34x61,5x4 cm 13"x24"x1 3/4"

beige

cotto

bianco

grigio

mix

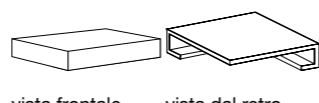

vista frontale vista dal retro  
angolare costa retta dx/sx  
34x34x4 cm 13"x13"x1 3/4"  103,40/PZ

beige

cotto

bianco

grigio

mix

Note - Notes - Notes - Anmerkungen

I battiscopa vengono venduti a pz. e a scatola completa. Tutti gli altri pezzi speciali vengono venduti al pezzo. I gradini vengono prodotti solo su ordinazione (tempo minimo di consegna 20 gg lavorativi).

Skirtings are sold by piece and full boxes. All other special trims are sold by piece. Steps are produced only on request (minimum delivery terms of 20 days).

Les plinthes sont vendues la pièce et par boîte complète. Les autres pièces spéciales sont vendues la pièce. Le plat de marche sont produit sur demande (délai minimum de 20 jours).

Die Sockelleisten werden pro Stk. und Vollen Kartons verkauft. Stufen und Stufenecken werden nur auf Bestellung produziert (Lieferzeiten mindesten 20 arbeitstagen ab Auftragserteilung).

# METEORA

sviluppo grafico . design development

mix - 20x20 cm 8"x8"  N



bianco - 20x20 cm 8"x8"  N



MIX | 20x20 cm NS outdoor\_8"x8" NS outdoor



# MY S'TILE

---

*Grès porcellanato impasto colorato*  
*Color body porcelain stoneware . Grès cérame coloré dans la masse . Durchgefärbtes Feinsteinzeug*

*effetto cemento*  
*concrete-look*  
*effet ciment*  
*zementoptik*

MY CAMEL MY SAND MY WHITE MY GREY



*Pensata per i grandi progetti residenziali pubblici e privati grazie all'opzione "outdoor" ed alla disponibilità di numerosi formati sviluppati su quattro colori, questa linea si presenta sobria, essenziale e rigorosamente minimale.*

*Al passo con gli stili ed i gusti dell'abitare contemporaneo trasforma le superfici donando loro un effetto estetico di grande equilibrio*

---

*Designed for large projects both in the home and in public spaces thanks to the "outdoor" option and the availability of numerous formats in four colours, this line is simple, essential and strictly minimalist.*

*In line with the styles and tastes of contemporary living, it transforms any surface, creating a very harmonious overall effect.*

*Conçue pour les grands projets résidentiels publics et privés grâce à l'option "outdoor" et à la disponibilité de nombreux formats développés sur quatre couleurs, cette ligne se présente comme sobre, essentielle et rigoureusement minimaliste.*

*En phase avec les styles et les goûts de l'habitat contemporain elle transforme les surfaces en leur conférant un effet esthétique de grand équilibre.*

*Diese Kollektion ist dank der „Outdoor“-Option und der Verfügbarkeit zahlreicher Größen in vier Farben für große öffentliche und private Wohnprojekte ideal. Die Linie ist schlicht, essentiell und verkörpert strikt den Minimalstil. Im Einklang mit den Stilen und Geschmäckern des zeitgenössischen Wohnens verwandelt „My s'tile“ Oberflächen und verleiht ihnen eine ästhetische Wirkung von großer Ausgewogenheit.*





# MY S'TILE

Impasto Colorato  
Colored Body  
Masse Colorée  
Durchgefärbt



**R** Rettificato  
Rectified

**RS** Rettificato/Strutturato  
Rectified/Textured

# MY S'TILE

Per la disponibilità articolo: [www.tuscaniagres.it](http://www.tuscaniagres.it)  
digitando il codice web segnalato a lato dei formati.  
For the item's availability: [www.tuscaniagres.it](http://www.tuscaniagres.it)  
type the web code reported next to the sizes.  
Pour vérifier la disponibilité de l'article: [www.tuscaniagres.it](http://www.tuscaniagres.it)  
en saisissant le code web indiqué à côté des formats.  
Für die Artikelverfügbarkeit: [www.tuscaniagres.it](http://www.tuscaniagres.it)  
web code eingeben, an der Seite von Formaten angedeutet.

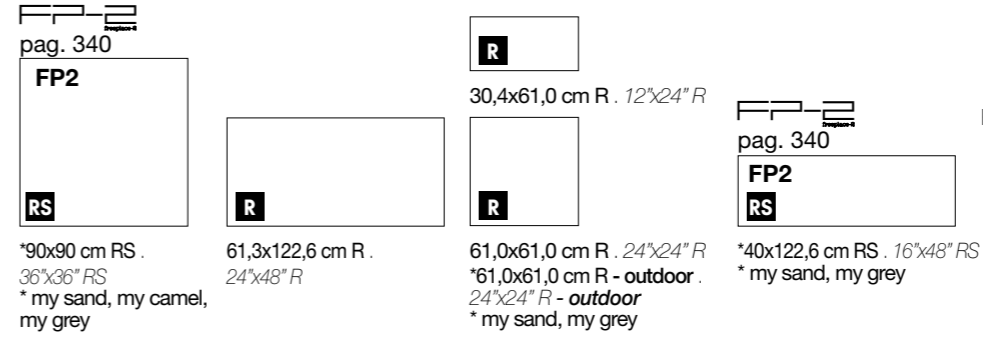
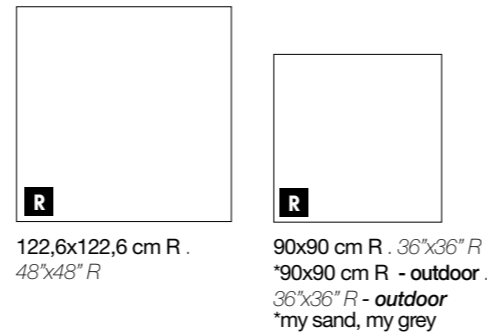

## my camel



L9S6	122,6x122,6 cm 48"x48"	<b>R</b>	54,02
L4T5	90x90 cm 36"x36"	<b>R</b>	44,75
L8V8	61,3x122,6 cm 24"x48"	<b>R</b>	44,75
L8V2	61,0x61,0 cm 24"x24"	<b>R</b>	37,04
L9V2	30,4x61,0 cm 12"x24"	<b>R</b>	33,95
<b>FP2</b>			
L9V9	90x90 cm 36"x36" FP2	<b>RS</b>	74,08

## my sand



L9S8	122,6x122,6 cm 48"x48"	<b>R</b>	54,02
L4T7	90x90 cm 36"x36"	<b>R</b>	44,75
L4T8	90x90 cm 36"x36" OUTDOOR	<b>R</b>	46,30
L9V0	61,3x122,6 cm 24"x48"	<b>R</b>	44,75
L8V4	61,0x61,0 cm 24"x24"	<b>R</b>	37,04
L8V7	61,0x61,0 cm 24"x24" OUTDOOR	<b>R</b>	38,58
L9V4	30,4x61,0 cm 12"x24"	<b>R</b>	33,95
<b>FP2</b>			
L9V8	90x90 cm 36"x36" FP2	<b>RS</b>	74,08
L9V7	40x122,6 cm 16"x48" FP2	<b>RS</b>	72,54

## my white



L9S5	122,6x122,6 cm 48"x48"	<b>R</b>	54,02
L4T4	90x90 cm 36"x36"	<b>R</b>	44,75
L9V1	61,3x122,6 cm 24"x48"	<b>R</b>	44,75
L8V5	61,0x61,0 cm 24"x24"	<b>R</b>	37,04
L9V5	30,4x61,0 cm 12"x24"	<b>R</b>	33,95

## my grey



L9S7	122,6x122,6 cm 48"x48"	<b>R</b>	54,02
L4T6	90x90 cm 36"x36"	<b>R</b>	44,75
L4T9	90x90 cm 36"x36" OUTDOOR	<b>R</b>	46,30
L8V9	61,3x122,6 cm 24"x48"	<b>R</b>	44,75
L8V3	61,0x61,0 cm 24"x24"	<b>R</b>	37,04
L8V6	61,0x61,0 cm 24"x24" OUTDOOR	<b>R</b>	38,58
L9V3	30,4x61,0 cm 12"x24"	<b>R</b>	33,95
<b>FP2</b>			
L0W0	90x90 cm 36"x36" FP2	<b>RS</b>	74,08
L9V6	40x122,6 cm 16"x48" FP2	<b>RS</b>	72,54

# MY S'TILE

MY S'TILE

decori - decors - décors - dekors

mosaico monocolore 81 tessere 3x3 - 30x30 cm 12"x12"  **13,27/PZ**



mosaico asimmetrico 18 pz - 30x30 cm 12"x12"  **13,27/PZ**



pezzi speciali - special pieces - pièces spéciales - formteile



**battiscopa**  **9,26/PZ**  
 6,5x122,6 cm R 2 1/2"x48" R  
 my camel  
 my sand  
 my white  
 my grey



**elemento "L" monolitico outdoor**  
 15x61x4 cm 6"x24"x1 3/4"  
**33,95/PZ**  
 my sand  
 my grey

**vista frontale** **vista dal retro**  
**angolare costa retta dx/sx**  
 30,5x122,6x4 cm 12"x48"x1 3/4" **200,62/PZ**  
 34x34x4 cm 13"x13"x1 3/4" **103,40/PZ**  
 my camel  
 my sand  
 my white  
 my grey

**step**  
 30,4x61,0 cm 12"x24" **15,45/PZ**  
 my camel  
 my sand  
 my white  
 my grey

**gradino costa retta**   
 30,5x122,6x4 cm 12"x48"x1 3/4" **163,58/PZ**  
 34x61,0x4 cm 13"x24"x1 3/4" **83,33/PZ**  
 my camel  
 my sand  
 my white  
 my grey

Note - Notes - Notes - Anmerkungen

I battiscopa vengono venduti a pz. e a scatola completa. Tutti gli altri pezzi speciali vengono venduti al pezzo. I gradini vengono prodotti solo su ordinazione (tempo minimo di consegna 20 gg lavorativi).  
 Skirtings are sold by piece and full boxes. All other special trims are sold by piece. Steps are produced only on request (minimum delivery terms of 20 days).  
 Les plinthes sont vendues la pièce et par boîte complète. Les autres pièces spéciales sont vendues la pièce. Le plat de marche sont produit sur demande (délai minimum de 20 jours).  
 Die Sockelleisten werden pro Stk. und Vollen Kartons verkauft. Stufen und Stufenecken werden nur auf Bestellung produziert (Lieferzeiten mindesten 20 arbeitstagen ab Auftragserteilung).

MY GREY | 122,6x122,6 cm R\_48"x48" R





# ATELIER

*Grès porcellanato impasto colorato*

*Color body porcelain stoneware . Grès cérame coloré dans la masse . Durchgefärbtes Feinsteinzeug*

*effetto cemento  
concrete-look  
effet ciment  
zementoptik*



*Il design ceramico si sta rivolgendo sempre più spesso e con indiscusso successo anche ai grandi formati pavimentali.*

*Non fa eccezione questa serie pensata per definire spazi decorativi particolarmente raffinati anche su vaste superfici. Le quattro colorazioni di base sono affiancate da moduli di eguale misura decorati con una texture geometrica leggerissima, tono su tono ed a tutto campo. Il risultato scenografico è inedito ed imprevedibile, in ogni caso molto piacevole.*

*Ceramic design is moving more and more and with undisputed success also to large slabs for flooring.*

*This series, designed to define particularly sophisticated decorative spaces even over vast surfaces, is no exception. The four basic shades are matched with modules in the same size, decorated with an ultra-light geometric texture, tone-on-tone, over the entire surface. The result is stunning, unusual and unexpected, and always pleasant.*

*Le design céramique s'adresse de plus en plus souvent et avec un succès indéniable aux grands formats pour sols.*

*N'y fait pas exception cette série conçue pour définir des espaces décoratifs particulièrement raffinés même sur des surfaces étendues. Les quatre colorations de base sont complétées par des modules de mesure identique décorés avec une texture géométrique très légère, ton sur ton et sur toute la superficie.*

*Auch das keramische Design wendet sich immer häufiger und mit unbestreitbarem Erfolg den großformatigen Bodenplatten zu. Diese Serie bildet da keine Ausnahme. Sie ist dafür bestimmt, auch auf großen Flächen besonders edle Dekorationsbereiche zu definieren. Die vier Grundfarben werden durch gleich große Module ergänzt, die mit einer sehr leichten geometrischen Textur, Ton-in-Ton und flächendeckend verziert sind. Ein spektakuläres Ergebnis, das nicht nur neuartig und überraschend ist, sondern auch sehr behaglich wirkt.*





# ATELIER

Impasto Colorato  
Colored Body  
Masse Colorée  
Durchgefärbt



30,4x61,0 cm R  
12"x24" R

**R** Rettificato  
Rectified

**RS** Rettificato/Strutturato  
Rectified/Textured

greige



L6V2	90x90 cm 36"x36"	<b>R</b>	44,75
L7W7	90x90 cm 36"x36" OUTDOOR	<b>R</b>	46,30
L6V6	90x90 cm 36"x36" DECORO	<b>R</b>	60,49
L7V0	61,3x122,6 cm 24"x48"	<b>R</b>	44,75
L5V4	61,0x61,0 cm 24"x24"	<b>R</b>	37,04
L5V8	61,0x61,0 cm 24"x24" DECORO	<b>R</b>	46,30
L7V5	30,4x61,0 cm 12"x24"	<b>R</b>	33,95

L7V9	90x90 cm 36"x36" FP2	<b>RS</b>	74,08
------	----------------------	-----------	-------

FP2  
pag. 338

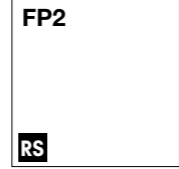

90x90 cm RS  
36"x36" RS

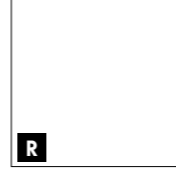

90x90 cm R . 36"x36" R  
90x90 cm R - DECORO . 36"x36" - DECORO  
\*90x90 cm R - outdoor . 36"x36" R - outdoor  
\*greige, brun, gris

brun



L6V4	90x90 cm 36"x36"	<b>R</b>	44,75
L7W9	90x90 cm 36"x36" OUTDOOR	<b>R</b>	46,30
L6V8	90x90 cm 36"x36" DECORO	<b>R</b>	60,49
L7V1	61,3x122,6 cm 24"x48"	<b>R</b>	44,75
L5V6	61,0x61,0 cm 24"x24"	<b>R</b>	37,04
L6V0	61,0x61,0 cm 24"x24" DECORO	<b>R</b>	46,30
L7V6	30,4x61,0 cm 12"x24"	<b>R</b>	33,95

L8V0	90x90 cm 36"x36" FP2	<b>RS</b>	74,08
------	----------------------	-----------	-------

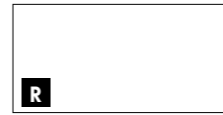

61,3x122,6 cm R . 24"x48" R



61,0x61,0 cm R . 24"x24" R  
61,0x61,0 cm R - DECORO .  
24"x24" R - DECORO

blanc

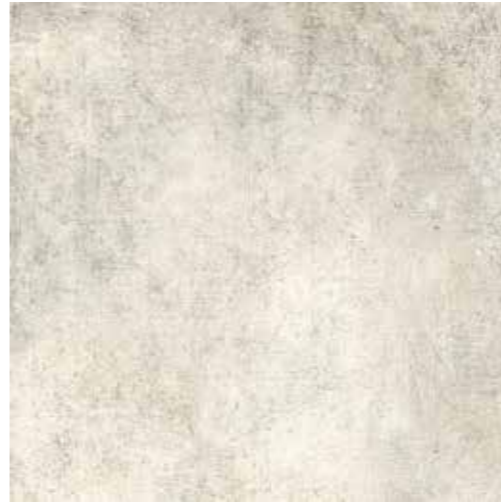

L6V3	90x90 cm 36"x36"	<b>R</b>	44,75
L6V7	90x90 cm 36"x36" DECORO	<b>R</b>	60,49
L7V2	61,3x122,6 cm 24"x48"	<b>R</b>	44,75
L5V5	61,0x61,0 cm 24"x24"	<b>R</b>	37,04
L5V9	61,0x61,0 cm 24"x24" DECORO	<b>R</b>	46,30
L7V4	30,4x61,0 cm 12"x24"	<b>R</b>	33,95

L7V8	90x90 cm 36"x36" FP2	<b>RS</b>	74,08
------	----------------------	-----------	-------



30,4x61,0 cm R . 12"x24" R

gris



L6V5	90x90 cm 36"x36"	<b>R</b>	44,75
L7W8	90x90 cm 36"x36" OUTDOOR	<b>R</b>	46,30
L6V9	90x90 cm 36"x36" DECORO	<b>R</b>	60,49
L7V3	61,3x122,6 cm 24"x48"	<b>R</b>	44,75
L5V7	61,0x61,0 cm 24"x24"	<b>R</b>	37,04
L6V1	61,0x61,0 cm 24"x24" DECORO	<b>R</b>	46,30
L7V7	30,4x61,0 cm 12"x24"	<b>R</b>	33,95

L8V1	90x90 cm 36"x36" FP2	<b>RS</b>	74,08
------	----------------------	-----------	-------

decori - decors - décors - dekors

**decoro** 90x90 cm 36"x36" 16 soggetti diversi, miscelazione casuale. Disponibile in tutti i colori. - 16 assorted motifs, random mix. Available in all colours.  
16 sujets différents, melange aleatoire. Disponible dans toutes les gammes de couleur. - 16 verschiedene Motive, Zufallsmischung. In allen Farben verfügbar.  
61,0x61,0 cm 24"x24" **R** 25 soggetti diversi, miscelazione casuale. Disponibile in tutti i colori. - 25 assorted motifs, random mix. Available in all colours.  
25 sujets différents, melange aleatoire. Disponible dans toutes les gammes de couleur. - 25 verschiedene Motive, Zufallsmischung. In allen Farben verfügbar.

greige



L6V6	90x90 cm 36"x36"	<b>R</b>	
L5V8	61,0x61,0 cm 24"x24"	<b>R</b>	

brun



L6V8	90x90 cm 36"x36"	<b>R</b>	
L6V0	61,0x61,0 cm 24"x24"	<b>R</b>	

decori - decors - décors - dekors

**decoro** 90x90 cm 36"x36" 16 soggetti diversi, miscelazione casuale. Disponibile in tutti i colori. - 16 assorted motifs, random mix. Available in all colours.  
16 sujets différents, melange aleatoire. Disponible dans toutes les gammes de couleur. - 16 verschiedene Motive, Zufallsmischung. In allen Farben verfügbar.  
61,0x61,0 cm 24"x24" **R** 25 soggetti diversi, miscelazione casuale. Disponibile in tutti i colori. - 25 assorted motifs, random mix. Available in all colours.  
25 sujets différents, melange aleatoire. Disponible dans toutes les gammes de couleur. - 25 verschiedene Motive, Zufallsmischung. In allen Farben verfügbar.

blanc



L6V7	90x90 cm 36"x36"	<b>R</b>	
L5V9	61,0x61,0 cm 24"x24"	<b>R</b>	

gris



L6V9	90x90 cm 36"x36"	<b>R</b>	
L6V1	61,0x61,0 cm 24"x24"	<b>R</b>	

# ATELIER

decori - decors - décors - dekors

**decoro** 90x90 cm 36"x36" 16 soggetti diversi, miscelazione casuale. Disponibile in tutti i colori. - 16 assorted motifs, random mix. Available in all colours.  
 16 sujets différents, mélange aléatoire. Disponible dans toutes les gammes de couleur. - 16 verschiedene Motive, Zufallsmischung. In allen Farben verfügbar.  
 61,0x61,0 cm 24"x24" **R** 25 soggetti diversi, miscelazione casuale. Disponibile in tutti i colori. - 25 assorted motifs, random mix. Available in all colours.  
 25 sujets différents, mélange aléatoire. Disponible dans toutes les gammes de couleur. - 25 verschiedene Motive, Zufallsmischung. In allen Farben verfügbar.

brun

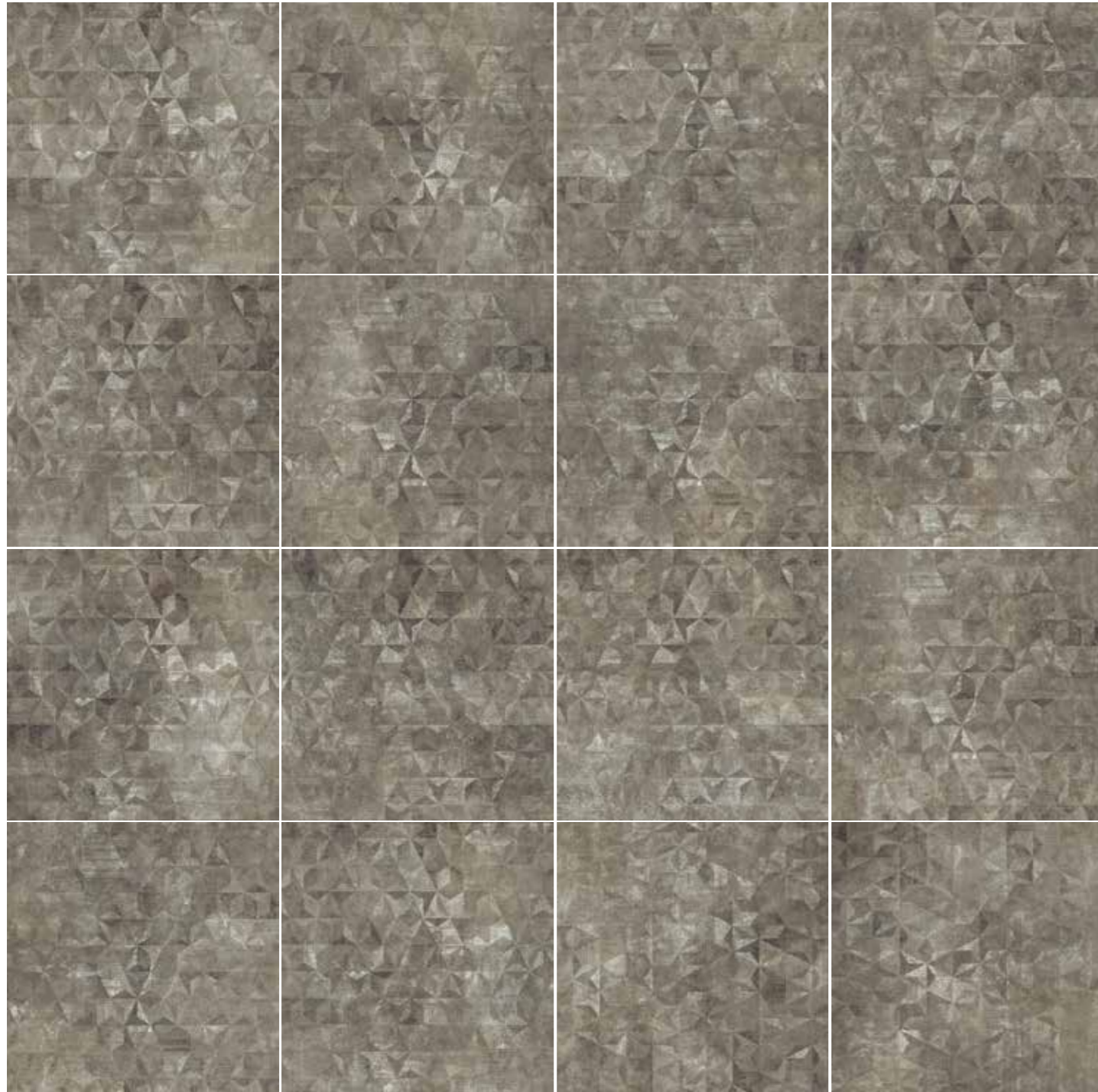

**L6V8** 90x90 cm 36"x36" **mix** **R**  
**L6V0** 61,0x61,0 cm 24"x24" **mix** **R**

ATELIER

decori - decors - décors - dekors

mosaico monocoloro 81 tessere 3x3 - 30x30 cm 12"x12" **7** **13,27/PZ**

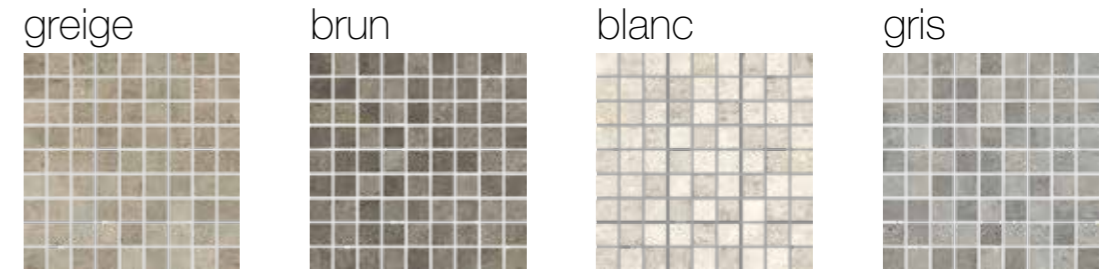

mosaico asimmetrico 18 pz - 30x30 cm 12"x12" **9** **13,27/PZ**

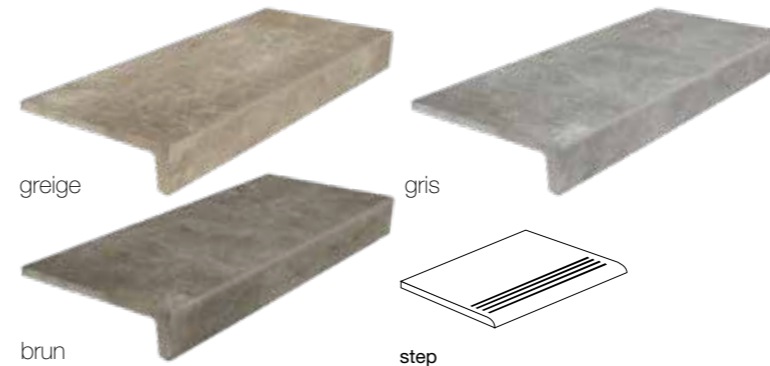
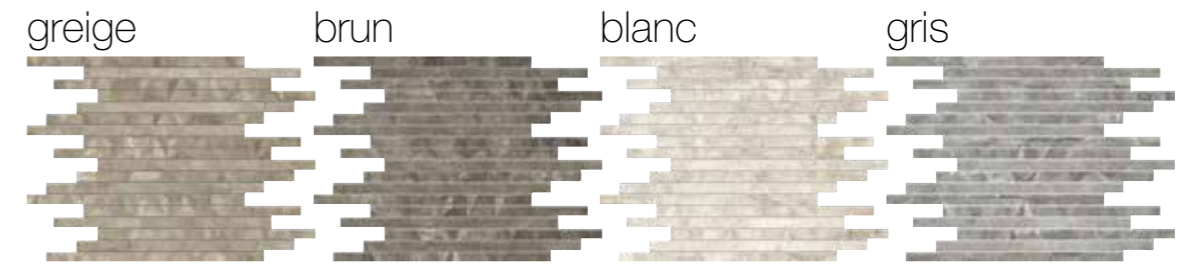

greige **33,95/PZ**  
 brun  
 greige  
 brun  
 gris

gris **15,45/PZ**  
 step 30,4x61,0 cm 12"x24"  
 greige  
 brun  
 blanc  
 gris

vista frontale **200,62/PZ**  
 angolare costa retta dx/sx 30,5x122,6x4 cm 12"x48"x1 3/4"  
 34x34x4 cm 13"x13"x1 3/4"  
 greige  
 brun  
 blanc  
 gris

vista dal retro **103,40/PZ**

gradino costa retta **163,58/PZ**  
 30,5x122,6x4 cm 12"x48"x1 3/4"  
 34x61,0x4 cm 13"x24"x1 3/4"  
 greige  
 brun  
 blanc  
 gris

pezzi speciali - special pieces -  
 pièces spéciales - formteile

greige  
 brun  
 blanc  
 gris **9,26/PZ**  
 battiscopa **10**  
 6,5x122,6 cm R 2 1/2"x48" R **R**

greige  
 brun  
 blanc  
 gris

Note - Notes - Notes - Anmerkungen

I battiscopa vengono venduti a pz. e a scatola completa. Tutti gli altri pezzi speciali vengono venduti al pezzo. I gradini vengono prodotti solo su ordinazione (tempo minimo di consegna 20 gg lavorativi).  
 Skirtings are sold by piece and full boxes. All other special trims are sold by piece. Steps are produced only on request (minimum delivery terms of 20 days).  
 Les plinthes sont vendues la pièce et par boîte complète. Les autres pièces spéciales sont vendus la pièce. Le plat de marche sont produit sur demande (délai minimum de 20 jours).  
 Die Sockelleisten werden pro Stk. und Vollen Kartons verkauft. Stufen und Stufenecken werden nur auf Bestellung produziert (Lieferzeiten mindesten 20 arbeitstagen ab Auftragserteilung).

# FEEL

---

*Grès porcellanato impasto colorato*

*Color body porcelain stoneware . Grès cérame coloré dans la masse . Durchgefärbtes Feinsteinzeug*

*effetto cemento  
concrete-look  
effet ciment  
zementoptik*

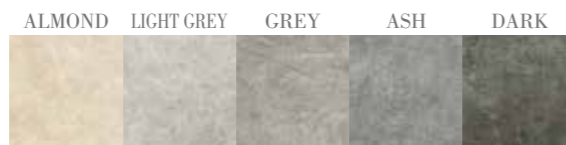

*La particolare eleganza di questa serie, che si ispira alla  
inconfondibile capacità di arredo della pietra,  
è in grado di definire interessanti soluzioni pavimentali  
per ambienti che necessitano di un forte carattere.  
I giochi superficiali, le sfumature e leggere striature sempre tono su tono  
seguono la tendenza di una moda che fa dello stile e  
dell'esclusività un elemento essenziale.*

---

*The particular elegance of this series, inspired by the  
unrivalled beauty of natural stone, can be used to create interesting flooring solutions  
for areas that require a bold touch of personality.*

*The patterns, shading and light streaks of colour, which are always tone-on-tone,  
follow the latest trends in fashion and have all the exclusivity of an essential element*

*L'élégance particulière de cette série, qui s'inspire de  
l'incomparable capacité d'ameublement de la pierre,  
est en mesure de définir d'intéressantes solutions pour sols  
dans des pièces qui appellent un fort caractère.*

*Les jeux de surface, les nuances et légères striures, toujours ton sur ton,  
suivent la tendance d'une mode qui fait du style et de l'exclusivité un élément essentiel*

*Die besondere Eleganz dieser Serie, für die das besondere Potenzial des Natursteins  
als Vorbild dient, schafft interessante Lösungen für Bodenbeläge in Räumen, die  
einen starken Charakter erfordern. Spiele mit Schattierungen und Nuancen und  
leichten Streifen auf der Oberfläche, stets Ton-in-Ton, liegen ganz im Trend. Stil und  
Exklusivität werden hier zu einem wesentlichen Element.*





# FEEL

Impasto Colorato  
Colored Body  
Masse Colorée  
Durchgefärbt



30,8x61,5 cm N  
12"x24" N  
30,4x61,0 cm R  
12"x24" R

outdoor

HIGH



Naturale  
Natural



Rettificato  
Rectified



61,5x61,5 cm N . 24"x24" N  
61,0x61,0 cm R . 24"x24" R



30,8x61,5 cm N . 12"x24" N  
30,4x61,0 cm R . 12"x24" R  
\*30,8x61,5 cm N - outdoor .  
12"x24" N - outdoor .  
\*grey, ash

## light grey

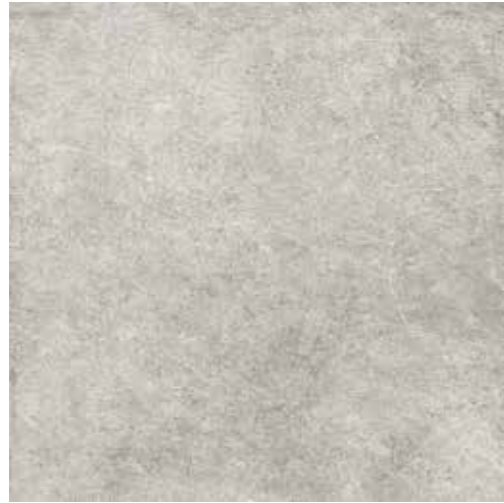

LOW1	61,5x61,5 cm 24"x24"	N	29,32
L1S4	61,0x61,0 cm 24"x24"	R	37,04
L6Q7	30,8x61,5 cm 12"x24"	N	24,69
LOR8	30,4x61,0 cm 12"x24"	R	33,95

## grey



LOW2	61,5x61,5 cm 24"x24"	N	29,32
L1S3	61,0x61,0 cm 24"x24"	R	37,04
L6Q6	30,8x61,5 cm 12"x24"	N	24,69
LON7	30,8x61,5 cm 12"x24" OUTDOOR	N	26,23
LOR7	30,4x61,0 cm 12"x24"	R	33,95

## ash

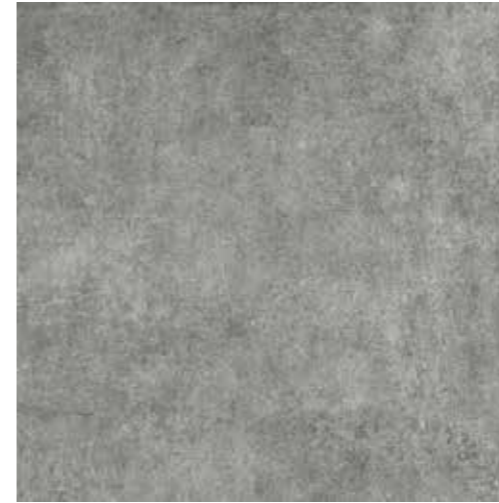

LOW4	61,5x61,5 cm 24"x24"	N	29,32
L1S2	61,0x61,0 cm 24"x24"	R	37,04
L6Q4	30,8x61,5 cm 12"x24"	N	24,69
LOW6	30,8x61,5 cm 12"x24" OUTDOOR	N	26,23
LOR5	30,4x61,0 cm 12"x24"	R	33,95

## dark



LOW3	61,5x61,5 cm 24"x24"	N	29,32
L1S6	61,0x61,0 cm 24"x24"	R	37,04
L6Q5	30,8x61,5 cm 12"x24"	N	24,69
LOR6	30,4x61,0 cm 12"x24"	R	33,95

## almond



LOW5	61,5x61,5 cm 24"x24"	N	29,32
L1S5	61,0x61,0 cm 24"x24"	R	37,04
L6Q3	30,8x61,5 cm 12"x24"	N	24,69
LOR4	30,4x61,0 cm 12"x24"	R	33,95

# FEEL

Per la disponibilità articolo: [www.tuscaniagres.it](http://www.tuscaniagres.it)  
digitando il codice web segnalato a lato dei formati.  
For the item's availability: [www.tuscaniagres.it](http://www.tuscaniagres.it)  
type the web code reported next to the sizes.  
Pour vérifier la disponibilité de l'article: [www.tuscaniagres.it](http://www.tuscaniagres.it)  
en saisissant le code web indiqué à coté des formats.  
Für die Artikelverfügbarkeit: [www.tuscaniagres.it](http://www.tuscaniagres.it)  
web code eingeben, an der Seite von Formaten angedeutet.

# FEEL

FEEL

decori - decors - décors - dekors

mosaico monocolor 36 tessere 5x5 - 30x30 cm 12"x12"  13,27/PZ

almond



light grey



grey



ash

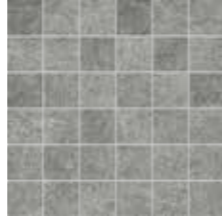

dark

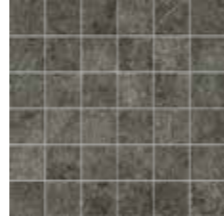

pezzi speciali - special pieces - pièces spéciales - formteile



almond



light grey



grey



ash



dark

**battiscopa**  **4,78/PZ**  
6,5x61,0 cm R 21/2"x24" R

almond  
light grey  
grey  
ash  
dark



grey



ash

**elemento "L" monolitico outdoor**  
15x61x4 cm 6"x24"x1 3/4" **33,95/PZ**

grey  
ash

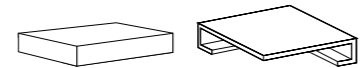

**vista frontale** **vista dal retro**  
angolare costa retta dx/sx  
34x34x4 cm 13"x13"x1 3/4" **103,40/PZ**

almond  
light grey  
grey  
ash  
dark

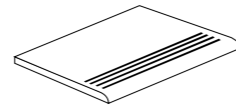

**step**  
30,8x61,5 cm 12"x24" **15,45/PZ**

almond  
light grey  
grey  
ash  
dark

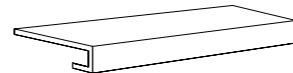

**gradino costa retta**  **83,33/PZ**  
34x61,0x4 cm 13"x24"x1 3/4"

almond  
light grey  
grey  
ash  
dark

Note - Notes - Notes - Anmerkungen

I battiscopa vengono venduti a pz. e a scatola completa. Tutti gli altri pezzi speciali vengono venduti al pezzo. I gradini vengono prodotti solo su ordinazione (tempo minimo di consegna 20 gg lavorativi).  
Skirtings are sold by piece and full boxes. All other special trims are sold by piece. Steps are produced only on request (minimum delivery terms of 20 days).  
Les plinthes sont vendues la pièce et par boîte complète. Les autres pièces spéciales sont vendues la pièce. Le plat de marche sont produit sur demande (délai minimum de 20 jours).  
Die Sockelleisten werden pro Stk. und Vollen Kartons verkauft. Stufen und Stufenecken werden nur auf Bestellung produziert (Lieferzeiten mindesten 20 arbeitstagen ab Auftragserteilung).

floor: ASH | 61,0x61,0 cm R\_24"x24" R  
wall: MANHATTAN BIANCO CRAQUELE | 7,5x30 cm\_3"x12"





# SHINE

---

*Grès porcellanato impasto colorato*

*Color body porcelain stoneware . Grès cérame coloré dans la masse . Durchgefärbtes Feinsteinzeug*

*effetto cemento  
concrete-look  
effet ciment  
zementoptik*



*Le misurate e ricercate variazioni cromatiche tipiche delle superfici in cemento creano un sorprendente risultato estetico di sapore decisamente hi-tech. Una ricchissima gamma di formati studiati su quattro colori che si prestano ad infinite soluzioni di posa.*

---

*The measured and refined colour variations typical of concrete surfaces create a beautiful aesthetic result with an extremely hi-tech feel. A wide range of formats in four colours that offer an infinite variety of laying schemes.*

*Modérées et raffinées, les variations chromatiques qui d'ordinaire caractérisent les surfaces en béton, créent un étonnant rendu esthétique résolument hi-tech. Une gamme de formats richissime, élaborée en quatre couleurs qui se prêtent à une infinité de calepinages.*

*Die typischen gemäßigten und erlesenen Farbvariationen der Zementoberflächen bilden ein überraschendes ästhetisches Ergebnis mit einem entschiedenen Hi-Tech-Stil. Ein reiches Angebot an Formaten mit vier Farben, die sich für unendliche Verlegungslösungen anbieten.*





# SHINE

Impasto Colorato  
Colored Body  
Masse Colorée  
Durchgefärbt



**R** Rettificato  
Rectified

sand



L0T8	90x90 cm 36"x36"	R	44,75
J1R9	75x75 cm 30"x30"	R	40,12
J5R6	61,3x122,6 cm 24"x48"	R	44,75
J2R3	61,0x61,0 cm 24"x24"	R	37,04
L1T2	61,0x61,0 cm 24"x24" OUTDOOR	R	38,58
J2R7	30,4x61,0 cm 12"x24"	R	33,95

grey



L1T0	90x90 cm 36"x36"	R	44,75
J2R1	75x75 cm 30"x30"	R	40,12
J5R8	61,3x122,6 cm 24"x48"	R	44,75
J2R5	61,0x61,0 cm 24"x24"	R	37,04
L1T3	61,0x61,0 cm 24"x24" OUTDOOR	R	38,58
J2R9	30,4x61,0 cm 12"x24"	R	33,95

white



L0T9	90x90 cm 36"x36"	R	44,75
J2R0	75x75 cm 30"x30"	R	40,12
J5R7	61,3x122,6 cm 24"x48"	R	44,75
J2R4	61,0x61,0 cm 24"x24"	R	37,04
J2R8	30,4x61,0 cm 12"x24"	R	33,95

anthracite



L1T1	90x90 cm 36"x36"	R	44,75
J2R2	75x75 cm 30"x30"	R	40,12
J5R9	61,3x122,6 cm 24"x48"	R	44,75
J2R6	61,0x61,0 cm 24"x24"	R	37,04
L1T4	61,0x61,0 cm 24"x24" OUTDOOR	R	38,58
J2R0	30,4x61,0 cm 12"x24"	R	33,95

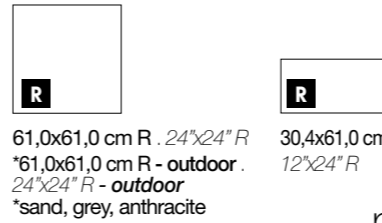
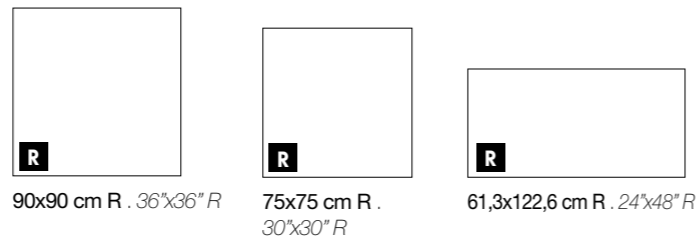

sand



sand

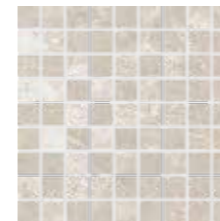

sand



white



white

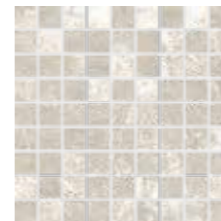

white



grey



grey



grey



anthracite



anthracite

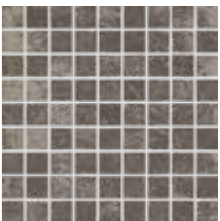

anthracite



mosaico monocolore 36 tessere 5x5 - 30x30 cm 12"x12" 13,27/PZ

mosaico monocolore 81 tessere 3x3 - 30x30 cm 12"x12" 13,27/PZ

mosaico asimmetrico 18 pz - 30x30 cm 12"x12" 13,27/PZ

pezzi speciali - special pieces - pièces spéciales - fornteile

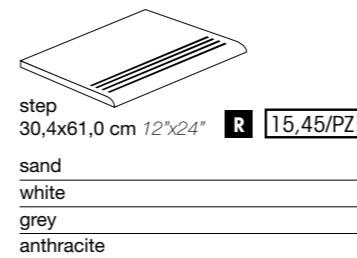

step  
30,4x61,0 cm 12"x24" **R** 15,45/PZ

sand  
white  
grey  
anthracite

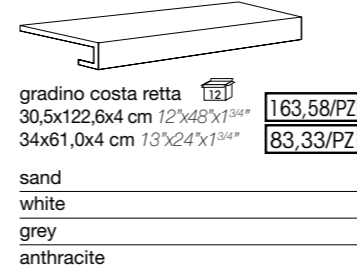

gradino costa retta   
30,5x122,6x4 cm 12"x48"x1<sup>3/4</sup>" **163,58/PZ**  
34x61,0x4 cm 13"x24"x1<sup>3/4</sup>" **83,33/PZ**

sand  
white  
grey  
anthracite

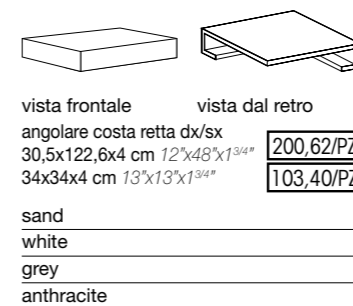

vista frontale vista dal retro  
angolare costa retta dx/sx  
30,5x122,6x4 cm 12"x48"x1<sup>3/4</sup>" **200,62/PZ**  
34x34x4 cm 13"x13"x1<sup>3/4</sup>" **103,40/PZ**

sand  
white  
grey  
anthracite



battiscopa   
6,5x122,6 cm R 2<sup>1/2</sup>"x48" R **R** 9,26/PZ

sand  
white  
grey  
anthracite

SHINE  
Per la disponibilità articolo: [www.tuscaniagres.it](http://www.tuscaniagres.it)  
digitando il codice web segnalato a lato dei formati.  
For the item's availability: [www.tuscaniagres.it](http://www.tuscaniagres.it)  
type the web code reported next to the sizes.  
Pour vérifier la disponibilité de l'article: [www.tuscaniagres.it](http://www.tuscaniagres.it)  
en saisissant le code web indiqué à coté des formats.  
Für die Artikelverfügbarkeit: [www.tuscaniagres.it](http://www.tuscaniagres.it)  
web code eingeben, an der Seite von Formaten angedeutet.

decori - decors - décors - dekors

I battiscopa vengono venduti a pz. e a scatola completa. Tutti gli altri pezzi speciali vengono venduti al pezzo. I gradini vengono prodotti solo su ordinazione (tempo minimo di consegna 20 gg lavorativi).  
Skirtings are sold by piece and full boxes. All other special trims are sold by piece. Steps are produced only on request (minimum delivery terms of 20 days).  
Les plinthes sont vendues la pièce et par boîte complète. Les autres pièces spéciales sont vendus la pièce. Le plat de marche sont produit sur demande (délai minimum de 20 jours).  
Die Sockelleisten werden pro Stk. und Vollen Kartons verkauft. Stufen und Stufenecken werden nur auf Bestellung produziert (Lieferzeiten mindesten 20 arbeitstagen ab Auftragserteilung).

# LEVEL

---

*Grès porcellanato impasto colorato*

*Color body porcelain stoneware . Grès cérame coloré dans la masse . Durchgefärbtes Feinsteinzeug*

*effetto cemento  
concrete-look  
effet ciment  
zementoptik*



*Un fondo ardesia impreziosito da nuance e striature superficiali tono su tono.*

*Graffiti multiformi, scritte metropolitane, numeri e timbri affiorano con leggera delicatezza dai decori.*

*Un materiale metropolitano per eccellenza che trasmette creatività e dinamismo ai moderni spazi abitativi.*

*A slate background embellished by nuances and tone-on-tone surface streaks.*

*Multifaceted graffiti, metropolitan writings, numbers and stamps emerge delicately from the decorations.*

*An excellent metropolitan material that adds creativity and dynamism to modern living spaces.*

*Un fond ardoise enrichi de nuances et de jaspures superficielles ton sur ton.*

*Multiformité des graffitis, urbanité des inscriptions, chiffres et tampons se montrent presque avec réserve sur les décors.*

*Urbanité d'un matériau qui transmet aux habitations modernes autant de créativité que de dynamisme.*

*Ein schiefergrauer Untergrund, der mit Nuancen und Ton-auf-Ton – Oberflächenstreifen aufgewertet ist.*

*Mehrförmige Graffiti, metropolitane Beschriftungen, Nummern und Einprägungen erscheinen mit der leichten Sanftheit der Dekorationen.*

*Ein absolut metropolitanes Material, das den modernen Wohnbereichen Kreativität und Dynamismus verleiht.*





# LEVEL

Impasto Colorato  
Colored Body  
Masse Colorée  
Durchgefärbt



R9

HD



V4

RANDOM

30,8x61,5 cm N  
12"x24" N  
30,4x61,0 cm R  
12"x24" R

**N** Naturale  
Natural

**R** Rettificato  
Rectified

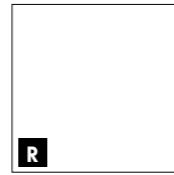

90x90 cm R . 36"x36" R



80x160 cm R . 31"x62" R



61,3x122,6 cm R . 24"x48" R  
61,3x122,6 cm R - DECORO  
24"x48" R - DECORO



61,5x61,5 cm N . 24"x24" N  
61,0x61,0 cm R . 24"x24" R



30,8x61,5 cm N . 12"x24" N  
30,4x61,0 cm R . 12"x24" R  
30,4x61,0 cm R - DECORO  
12"x24" R - DECORO

## LEVEL

Per la disponibilità articolo: [www.tuscaniagres.it](http://www.tuscaniagres.it)  
digitando il codice web segnalato a lato dei formati.  
For the item's availability: [www.tuscaniagres.it](http://www.tuscaniagres.it)  
type the web code reported next to the sizes.  
Pour vérifier la disponibilité de l'article: [www.tuscaniagres.it](http://www.tuscaniagres.it)  
en saisissant le code web indiqué à coté des formats.  
Für die Artikelverfügbarkeit: [www.tuscaniagres.it](http://www.tuscaniagres.it)  
web code eingeben, an der Seite von Formaten angedeutet.

white



L1T5	90x90 cm 36"x36"	R	44,75
L1T9	80x160 cm 31"x62"	R	52,47
J8O4	61,3x122,6 cm 24"x48"	R	44,75
JOP9	61,3x122,6 cm 24"x48" DECORO	R	66,36
J8O1	61,5x61,5 cm 24"x24"	N	29,32
J9O4	61,0x61,0 cm 24"x24"	R	37,04
J7O4	30,8x61,5 cm 12"x24"	N	24,69
J1R2	30,4x61,0 cm 12"x24"	R	33,95
L2W8	30,4x61,0 cm 12"x24" DECORO	R	43,21

grey



L1T6	90x90 cm 36"x36"	R	44,75
L2T0	80x160 cm 31"x62"	R	52,47
J8O5	61,3x122,6 cm 24"x48"	R	44,75
JOP8	61,3x122,6 cm 24"x48" DECORO	R	66,36
J8O0	61,5x61,5 cm 24"x24"	N	29,32
J6K3	61,0x61,0 cm 24"x24"	R	37,04
J7O5	30,8x61,5 cm 12"x24"	N	24,69
J1R3	30,4x61,0 cm 12"x24"	R	33,95
L2W9	30,4x61,0 cm 12"x24" DECORO	R	43,21

dark grey



L1T7	90x90 cm 36"x36"	R	44,75
L2T1	80x160 cm 31"x62"	R	52,47
J8O6	61,3x122,6 cm 24"x48"	R	44,75
JOP7	61,3x122,6 cm 24"x48" DECORO	R	66,36
J7O9	61,5x61,5 cm 24"x24"	N	29,32
J9O6	61,0x61,0 cm 24"x24"	R	37,04
J7O6	30,8x61,5 cm 12"x24"	N	24,69
J4S6	30,4x61,0 cm 12"x24"	R	33,95
L3W0	30,4x61,0 cm 12"x24" DECORO	R	43,21

anthracite



L1T8	90x90 cm 36"x36"	R	44,75
L2T2	80x160 cm 31"x62"	R	52,47
J8O7	61,3x122,6 cm 24"x48"	R	44,75
JOP6	61,3x122,6 cm 24"x48" DECORO	R	66,36
J7O8	61,5x61,5 cm 24"x24"	N	29,32
J9O7	61,0x61,0 cm 24"x24"	R	37,04
J7O7	30,8x61,5 cm 12"x24"	N	24,69
J6Q4	30,4x61,0 cm 12"x24"	R	33,95
L3W1	30,4x61,0 cm 12"x24" DECORO	R	43,21

rivestimento coordinato - matching wall tiles - faiences coordonnées - koordinierte wandfliesen:

LEVEL 20x50 cm 8"x20" - Bicottura tradizionale . Traditional double fired . Traditionnelle double feu . Zweibrandfliesen - pag. 382

white



grey



# LEVEL

decori - decors - décors - dekors

decoro 61,3x122,6 cm 24"x48" **R** - 30,4x61,0 cm 12"x24" **R**

white



J0P9 61,3x122,6 cm 24"x48" **R**  
L2W8 30,4x61,0 cm 12"x24" **R**

grey



J0P8 61,3x122,6 cm 24"x48" **R**  
L2W9 30,4x61,0 cm 12"x24" **R**

dark grey



J0P7 61,3x122,6 cm 24"x48" **R**  
L3W0 30,4x61,0 cm 12"x24" **R**

anthracite



J0P6 61,3x122,6 cm 24"x48" **R**  
L3W1 30,4x61,0 cm 12"x24" **R**

# LEVEL

decori - decors - décors - dekors

mosaico monocolor 36 tessere 5x5 - 30x30 cm 12"x12" **7** **13,27/PZ**

white

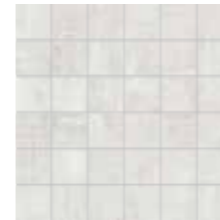

grey



dark grey



anthracite



white



grey



dark grey

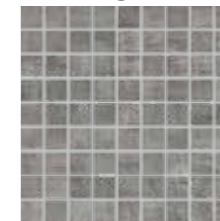

anthracite

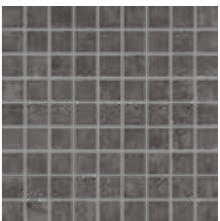

mosaico monocolor 81 tessere 3x3 - 30x30 cm 12"x12" **9** **13,27/PZ**

white



grey



dark grey



anthracite



mosaico asimmetrico 18 pz - 30x30 cm 12"x12" **9** **13,27/PZ**

pezzi speciali - special pieces - pièces spéciales - formteile

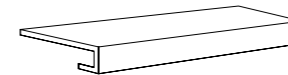

gradino costa retta **12**  
30,5x122,6x4 cm 12"x48"x1<sup>3</sup>/<sub>4</sub>" **163,58/PZ**  
34x61,5x4 cm 13"x24"x1<sup>3</sup>/<sub>4</sub>" **83,33/PZ**

white  
grey  
dark grey  
anthracite



vista frontale  
angolare costa retta dx/sx  
30,5x122,6x4 cm 12"x48"x1<sup>3</sup>/<sub>4</sub>" **200,62/PZ**  
34x34x4 cm 13"x13"x1<sup>3</sup>/<sub>4</sub>" **103,40/PZ**

white  
grey  
dark grey  
anthracite

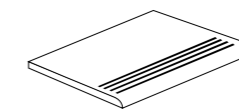

step  
30,8x61,5 cm 12"x24" **15,45/PZ**

white  
grey  
dark grey  
anthracite



white  
grey  
dark grey  
anthracite

battiscopa **12**  
6,5x61,5 cm 2<sup>1</sup>/<sub>2</sub>"x24" **4,78/PZ**

white  
grey  
dark grey  
anthracite

Note - Notes - Notes - Anmerkungen

I battiscopa vengono venduti a pz. e a scatola completa.  
Tutti gli altri pezzi speciali vengono venduti al pezzo. I gradini vengono prodotti solo su ordinazione (tempo minimo di consegna 20 gg lavorativi).  
Skirtings are sold by piece and full boxes.  
All other special trims are sold by piece.  
Steps are produced only on request (minimum delivery terms of 20 days).  
Les plinthes sont vendues la pièce et par boîte complete.  
Les autres pièces spéciales sont vendus la pièce.  
Le plat de marche sont produit sur demande (délai minimum de 20 jours).  
Die Sockelleisten werden pro Stk. und Vollen Kartons verkauft.  
Stufen und Stufenecken werden nur auf Bestellung produziert (Lieferzeiten mindesten 20 arbeitstagen ab Auftragserteilung).

# SCRATCH

*Grès porcellanato impasto colorato*  
*Color body porcelain stoneware . Grès cérame coloré dans la masse . Durchgefärbtes feinsteinzeug*

*effetto cemento*  
*concrete-look*  
*effet ciment*  
*zementoptik*



rivestimento coordinato - matching wall tiles - faïences coordonnées - koordinierte wandfliesen: **SCRATCH**



*Per la gioia dei più esigenti ecco tre scelte di superfici diverse  
 ma legate tra loro dagli stessi colori di fondo.*

*Una tipologia superficiale nuvolata, una in tinta unita  
 ed una in leggero bassorilievo.*

*Ed ecco che l'atmosfera d'insieme diventa essenziale  
 per un risultato finale impensabile.*

*To the joy of the most demanding people, three different surfaces  
 bound together by the same base colours.*

*One cloudy surface finish, one plain and one with light bas-relief.  
 Making the overall atmosphere essential, with an unimagined end result.*

*Pour la joie des plus exigeants, voici trois choix de surfaces différentes,  
 mais liées entre elles par les mêmes couleurs du fond.*

*Une typologie de surface rubanée, une autre dans une teinte unie et la dernière en léger bas-relief.  
 Et voici que l'atmosphère générale devient essentielle pour un résultat final impensable.*

*Zur Freude der anspruchsvollsten Kunden stehen hier drei unterschiedliche Oberflächen zur  
 Auswahl, die durch gleichfarbige Grundfliesen miteinander verbunden sind.*

*Eine melierte Oberfläche, eine einfarbige und eine in einem leichten Flachrelief.  
 Die Verbindung führt zu einem unerwarteten und überraschenden Gesamtergebnis.*







wall: NATURAL GREY | 30,4x61,0 cm R\_12"x24" R - MATT GREY e WHITE | 30,4x61,0 cm R\_12"x24" R  
floor: EMOTION GREY | 61,0x61,0 cm R\_24"x24" R

# SCRATCH

Impasto Colorato  
Colored Body  
Masse Colorée  
Durchgefärbt



**R** Rettificato  
Rectified

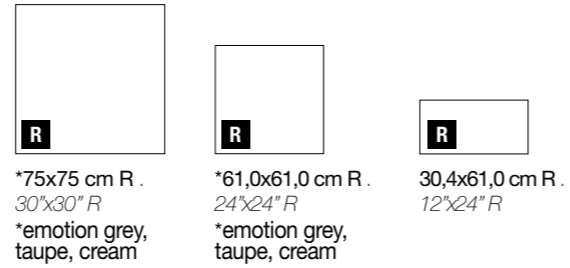

\*75x75 cm R .  
30"x30" R  
\*emotion grey,  
taupe, cream

\*61,0x61,0 cm R .  
24"x24" R  
\*emotion grey,  
taupe, cream

30,4x61,0 cm R .  
12"x24" R

SCRATCH

Per la disponibilità articolo: [www.tuscaniagres.it](http://www.tuscaniagres.it)  
digitando il codice web segnalato a lato dei formati.  
For the item's availability: [www.tuscaniagres.it](http://www.tuscaniagres.it)  
type the web code reported next to the sizes.  
Pour vérifier la disponibilité de l'article: [www.tuscaniagres.it](http://www.tuscaniagres.it)  
en saisissant le code web indiqué à coté des formats.  
Für die Artikelverfügbarkeit: [www.tuscaniagres.it](http://www.tuscaniagres.it)  
web code eingeben, an der Seite von Formaten angedeutet.

decori - decors - décors - dekors

## emotion cream



J8Q2	75x75 cm 30"x30"	<b>R</b>	40,12
J3S4	61,0x61,0 cm 24"x24"	<b>R</b>	37,04

## emotion taupe



J8Q4	75x75 cm 30"x30"	<b>R</b>	40,12
J9P5	61,0x61,0 cm 24"x24"	<b>R</b>	37,04

## mosaico monocolor mix E/M/N 81 tessere 3x3 - 30x30 cm 12"x12"

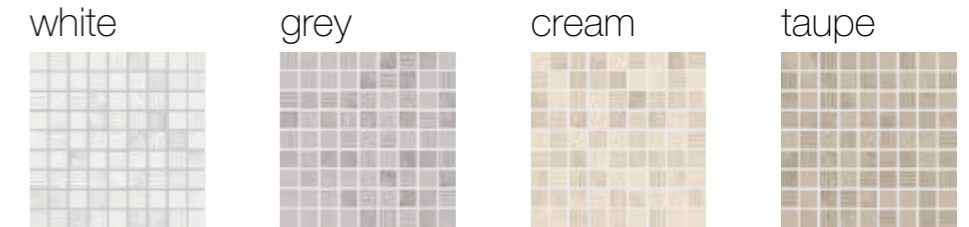

## emotion grey



J8Q3	75x75 cm 30"x30"	<b>R</b>	40,12
J5S7	61,0x61,0 cm 24"x24"	<b>R</b>	37,04

pezzi speciali - special pieces - pièces spéciales - formteile

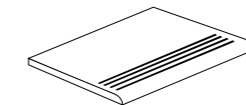

step  
30,4x61,0 cm 12"x24" **15,45/PZ**

emotion/matt white  
emotion/matt grey  
emotion/matt cream  
emotion/matt taupe

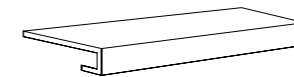

gradino costa retta   
\*34x61,0x4 cm 13"x24"x1<sup>3/4</sup>" **83,33/PZ**  
\*30,4x61,0x4 cm 12"x24"x1<sup>3/4</sup>" **83,33/PZ**

\*matt white  
\*emotion/\*matt grey  
\*emotion/\*matt cream  
\*emotion/\*matt taupe

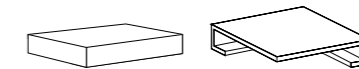

vista frontale      vista dal retro  
angolare costa retta dx/sx  
\*34x34x4 cm 13"x13"x1<sup>3/4</sup>" **103,40/PZ**  
\*30,4x30,4x4 cm 12"x12"x1<sup>3/4</sup>" **103,40/PZ**

\*matt white  
\*emotion/\*matt grey  
\*emotion/\*matt cream  
\*emotion/\*matt taupe



white



grey



cream



taupe

battiscopa   
7,5x61,0 cm R 3"x24" R **4,78/PZ**

emotion/matt white  
emotion/matt grey  
emotion/matt cream  
emotion/matt taupe

Note - Notes - Notes - Anmerkungen

I battiscopa vengono venduti a pz. e a scatola completa. Tutti gli altri pezzi speciali vengono venduti al pezzo. I gradini vengono prodotti solo su ordinazione (tempo minimo di consegna 20 gg lavorativi).  
Skirtinges are sold by piece and full boxes. All other special trims are sold by piece. Steps are produced only on request (minimum delivery terms of 20 days).  
Les plinthes sont vendues la pièce et par boîte complète. Les autres pièces spéciales sont vendus la pièce. Le plat de marche sont produit sur demande (délai minimum de 20 jours).  
Die Sockelleisten werden pro Stk. und Vollen Kartons verkauft. Stufen und Stufenecken werden nur auf Bestellung produziert (Lieferzeiten mindesten 20 arbeitstagen ab Auftragserteilung).

# SCRATCH

Impasto Colorato  
Colored Body  
Masse Colorée  
Durchgefärbt



V1



LOW  
matt, natural,  
glossy

V2



MODERATE  
emotion



matt,  
emotion



\*\*natural

**R** Rettificato  
Rectified

emotion white



I1U0 | 30,4x61,0 cm 12"x24" **R** 30,25

matt white

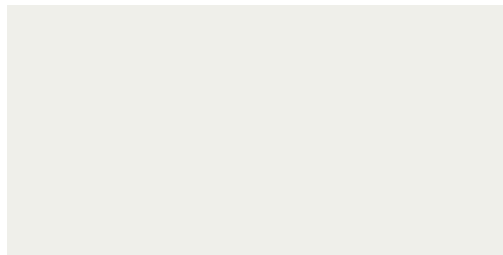

I1U4 | 30,4x61,0 cm 12"x24" **R** 29,32

\*\*natural white



I3P5 | 30,4x61,0 cm 12"x24" **R** 35,49

\*\*glossy white



I7R6 | 30,4x61,0 cm 12"x24" **R** 37,04

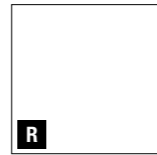

\*75x75 cm R .  
30"x30" R  
\*emotion grey,  
taupe, cream



\*61,0x61,0 cm R .  
24"x24" R  
\*emotion grey,  
taupe, cream



30,4x61,0 cm R .  
12"x24" R

emotion grey



J8Q3 | 75x75 cm 30"x30" **R** 40,12

J5S7 | 61,0x61,0 cm 24"x24" **R** 37,04

I1U2 | 30,4x61,0 cm 12"x24" **R** 30,25

matt grey

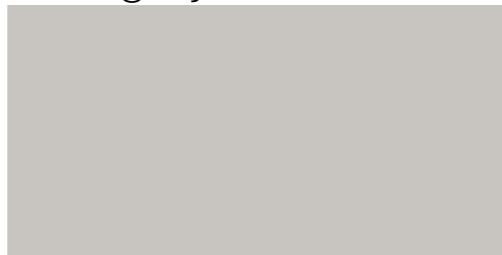

I1U6 | 30,4x61,0 cm 12"x24" **R** 29,32

\*\*natural grey



I8R2 | 30,4x61,0 cm 12"x24" **R** 35,49

emotion cream



J8Q2 | 75x75 cm 30"x30" **R** 40,12

J3S4 | 61,0x61,0 cm 24"x24" **R** 37,04

I1U1 | 30,4x61,0 cm 12"x24" **R** 30,25

matt cream

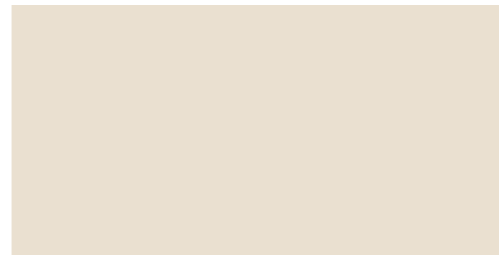

I1U5 | 30,4x61,0 cm 12"x24" **R** 29,32

\*\*natural cream

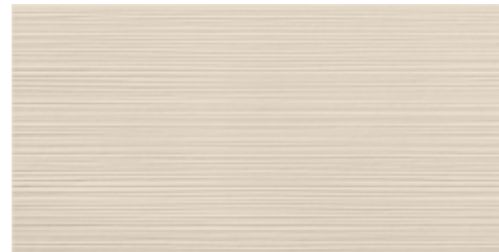

I6R2 | 30,4x61,0 cm 12"x24" **R** 35,49

emotion taupe



J8Q4 | 75x75 cm 30"x30" **R** 40,12

J9P5 | 61,0x61,0 cm 24"x24" **R** 37,04

I1U3 | 30,4x61,0 cm 12"x24" **R** 30,25

matt taupe



I1U7 | 30,4x61,0 cm 12"x24" **R** 29,32

\*\*natural taupe



I6R1 | 30,4x61,0 cm 12"x24" **R** 35,49

SCRATCH

Per la disponibilità articolo: [www.tuscaniagres.it](http://www.tuscaniagres.it)  
digitando il codice web segnalato a lato dei formati.  
For the item's availability: [www.tuscaniagres.it](http://www.tuscaniagres.it)  
type the web code reported next to the sizes.  
Pour vérifier la disponibilité de l'article: [www.tuscaniagres.it](http://www.tuscaniagres.it)  
en saisissant le code web indiqué à coté des formats.  
Für die Artikelverfügbarkeit: [www.tuscaniagres.it](http://www.tuscaniagres.it)  
web code eingeben, an der Seite von Formaten angedeutet.

\*\*Si raccomanda la posa solo a rivestimento  
It is recommended only the wall installation  
Nous conseillons de poser uniquement sur paroi  
Die Verlegung wird nur für die Wandverkleidung empfohlen

# TECHNIKA

*Grès porcellanato impasto colorato*

*Color body porcelain stoneware . Grès cérame coloré dans la masse . Durchgefärbtes Feinsteinzeug*

*effetto cemento  
concrete-look  
effet ciment  
zementoptik*



*Una scelta di particolare tendenza che mira ad esaltare un nuovo concetto di ceramica basata su materiali contemporanei come il cemento.*

*Si ottengono così pavimenti moderni ispirati allo stile industrial dove creatività e funzionalità si incontrano per un risultato estetico inconsueto e sorprendente.*

*Grazie ad una elevata resistenza tecnica, questa linea è ideale per spazi commerciali, residenziali e pubblici.*

*A particularly trendy choice that aims to exalt a new concept of ceramic based on contemporary materials such as concrete.*

*This allows modern floorings to be created that are inspired by the industrial style where creativity and practicality are combined to produce a totally unusual and astonishing effect.*

*Thanks to its superior technical resistance, this line is ideal for commercial, residential, and public spaces.*

*Un choix particulièrement tendance, qui vise à prôner un nouveau concept de céramique basé sur des matériaux contemporains tels que le béton.*

*Sont obtenus ainsi des sols modernes inspirés du style industriel où créativité et fonctionnalité se rencontrent pour un résultat esthétique inhabituel et surprenant.*

*Grâce à une résistance technique élevée, cette ligne est idéale pour les espaces commerciaux, résidentiels et publics.*

*ine Wahl, die ganz im Trend liegt und darauf abzielt, ein neues Konzept von Keramik auf der Basis von zeitgenössischen Materialien wie Zement zur Geltung zu bringen.*

*Das Ergebnis sind moderne Fußböden, die vom industriellen Stil inspiriert sind, wo sich Kreativität und Funktionalität zu einem ungewöhnlichen und überraschenden ästhetischen Ergebnis verbinden. Dank ihrer hohen technischen Beständigkeit ist diese Linie ideal für den gewerblichen, privaten und öffentlichen Bereich.*

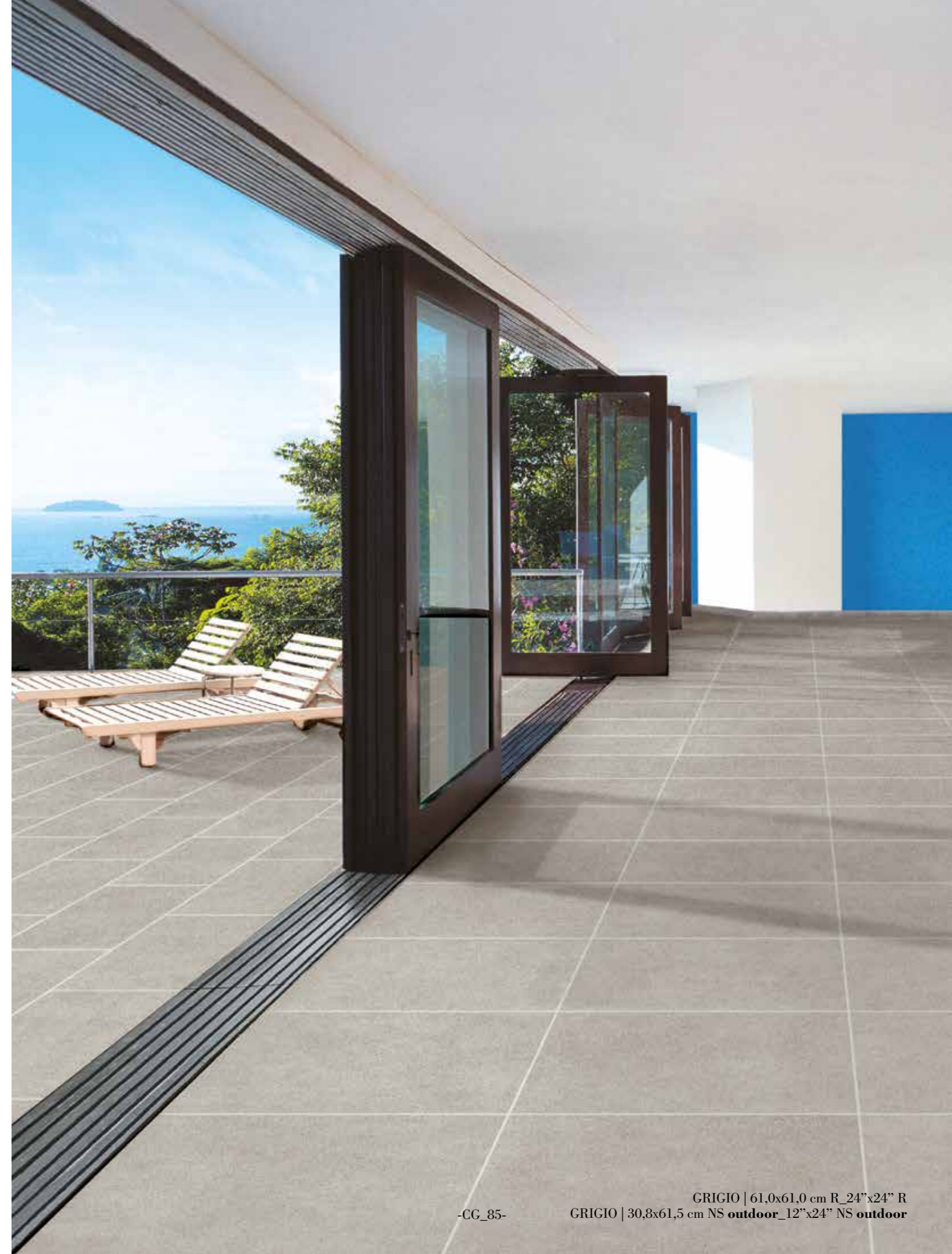

Impasto Colorato  
Colored Body  
Masse Colorée  
Durchgefärbt



45,5x45,5 cm N  
18"x18" N  
30,8x61,5 cm N  
12"x24" N  
30,4x61,0 cm R  
12"x24" R

**N** Naturale Natural  
**NS** Naturale/Strutturato Natural/Textured  
**R** Rettificato Rectified  
**RS** Rettificato/Strutturato Rectified/Textured



61,5x61,5 cm N . 24"x24" N  
\*61,5x61,5 cm NS - outdoor  
24"x24" NS - outdoor  
\*grigio, antracite  
61,0x61,0 cm R . 24"x24" R



pag. 344

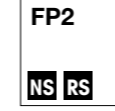

\*61,5x61,5 cm NS .  
24"x24" NS  
\*61,0x61,0 cm RS .  
24"x24" RS  
\*grigio, antracite



45,5x45,5 cm N  
18"x18" N



30,8x61,5 cm N . 12"x24" N  
\*30,8x61,5 cm NS - outdoor .  
12"x24" NS - outdoor  
\*grigio, antracite  
30,4x61,0 cm R . 12"x24" R

Per la disponibilità articolo: [www.tuscaniagres.it](http://www.tuscaniagres.it)  
digitando il codice web segnalato a lato dei formati.  
For the item's availability: [www.tuscaniagres.it](http://www.tuscaniagres.it)  
type the web code reported next to the sizes.  
Pour vérifier la disponibilité de l'article: [www.tuscaniagres.it](http://www.tuscaniagres.it)  
en saisissant le code web indiqué à côté des formats.  
Für die Artikelverfügbarkeit: [www.tuscaniagres.it](http://www.tuscaniagres.it)  
web code eingeben, an der Seite von Formaten angedeutet.

## beige



I3I2	61,5x61,5 cm 24"x24"	<b>N</b>	29,32
I3I7	61,0x61,0 cm 24"x24"	<b>R</b>	37,04
I4I6	45,5x45,5 cm 18"x18"	<b>N</b>	23,15
I2H9	30,8x61,5 cm 12"x24"	<b>N</b>	24,69
I2I6	30,4x61,0 cm 12"x24"	<b>R</b>	33,95

## taupe



I3I6	61,5x61,5 cm 24"x24"	<b>N</b>	29,32
I4I1	61,0x61,0 cm 24"x24"	<b>R</b>	37,04
I5I0	45,5x45,5 cm 18"x18"	<b>N</b>	23,15
I3H3	30,8x61,5 cm 12"x24"	<b>N</b>	24,69
I3I0	30,4x61,0 cm 12"x24"	<b>R</b>	33,95

## bianco



I3I3	61,5x61,5 cm 24"x24"	<b>N</b>	29,32
I3I8	61,0x61,0 cm 24"x24"	<b>R</b>	37,04
I4I7	45,5x45,5 cm 18"x18"	<b>N</b>	23,15
I3H0	30,8x61,5 cm 12"x24"	<b>N</b>	24,69
I2I7	30,4x61,0 cm 12"x24"	<b>R</b>	33,95

## grigio



I3I4	61,5x61,5 cm 24"x24"	<b>N</b>	29,32
J8Q6	61,5x61,5 cm 24"x24" OUTDOOR	<b>NS</b>	30,86
I3I9	61,0x61,0 cm 24"x24"	<b>R</b>	37,04
I4I8	45,5x45,5 cm 18"x18"	<b>N</b>	23,15
I3H1	30,8x61,5 cm 12"x24"	<b>N</b>	24,69
I4H8	30,8x61,5 cm 12"x24" OUTDOOR	<b>NS</b>	26,23
I2I8	30,4x61,0 cm 12"x24"	<b>R</b>	33,95



I6H9	61,5x61,5 cm 24"x24" FP2	<b>NS</b>	55,56
I5O2	61,0x61,0 cm 24"x24" FP2	<b>RS</b>	67,90

## antracite

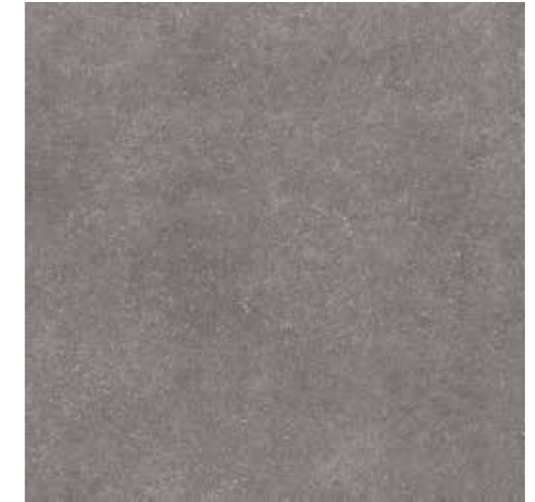

I3I5	61,5x61,5 cm 24"x24"	<b>N</b>	29,32
J8Q7	61,5x61,5 cm 24"x24" OUTDOOR	<b>NS</b>	30,86
I4I0	61,0x61,0 cm 24"x24"	<b>R</b>	37,04
I4I9	45,5x45,5 cm 18"x18"	<b>N</b>	23,15
I3H2	30,8x61,5 cm 12"x24"	<b>N</b>	24,69
I4H7	30,8x61,5 cm 12"x24" OUTDOOR	<b>NS</b>	26,23
I2I9	30,4x61,0 cm 12"x24"	<b>R</b>	33,95

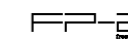

I3I1	61,5x61,5 cm 24"x24" FP2	<b>NS</b>	55,56
I8N3	61,0x61,0 cm 24"x24" FP2	<b>RS</b>	67,90

decori - decors - décors - dekors

patchwork - 30x30 cm 12"x12"  20,37/PZ



mosaico monocolore 36 tessere 5x5 - 30x30 cm 12"x12"  13,27/PZ



pezzi speciali - special pieces - pièces spéciales - formteile

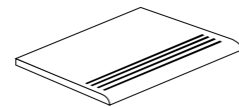

step  
30,8x61,5 cm 12"x24" **15,45/PZ**  
beige  
taupe  
bianco  
grigio  
antracite

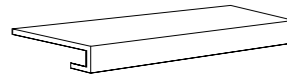

gradino costa retta  
34x61,5x4 cm 13"x24"x1 3/4" **83,33/PZ**  
beige  
taupe  
bianco  
grigio  
antracite

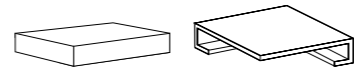

vista frontale vista dal retro  
angolare costa retta dx/sx  
34x34x4 cm 13"x13"x1 3/4" **103,40/PZ**  
beige  
taupe  
bianco  
grigio  
antracite

battiscopa  4,78/PZ  
6,5x61,5 cm 2 1/2"x24"  
beige  
taupe  
bianco  
grigio  
antracite

Note - Notes - Notes - Anmerkungen  
I battiscopa vengono venduti a pz. e a scatola completa. Tutti gli altri pezzi speciali vengono venduti al pezzo. I gradini vengono prodotti solo su ordinazione (tempo minimo di consegna 20 gg lavorativi).  
Skirtings are sold by piece and full boxes. All other special trims are sold by piece. Steps are produced only on request (minimum delivery terms of 20 days).  
Les plinthes sont vendues la pièce et par boîte complète. Les autres pièces spéciales sont vendus la pièce. Le plat de marche sont produit sur demande (délai minimum de 20 jours).  
Die Sockelleisten werden pro Stk. und Vollen Kartons verkauft. Stufen und Stufenecken werden nur auf Bestellung produziert (Lieferzeiten mindesten 20 arbeitstagen ab Auftragserteilung).

BIANCO | 61,0x61,0 cm R\_24"x24" R



# GREY SOUL

---

*Grès porcellanato impasto colorato*

*Color body porcelain stoneware . Grès cérame coloré dans la masse . Durchgefärbtes Feinsteinzeug*

*effetto cemento  
concrete-look  
effet ciment  
zementoptik*



*Un'idea per decorare la vostra casa secondo uno stile particolarmente elegante,  
contando su una larga gamma di colori e grandi formati.*

*Una serie importante che consolida una tradizione ceramica di alto livello qualitativo,  
che dialoga contemporaneamente con il gusto delle ultime tendenze abitative.*

---

*An idea for decorating your home in a particularly elegant style,  
relying on a vast range of colours and large formats.*

*An important series that consolidates the finest quality in ceramic traditions  
with the contemporary taste of the latest living trends.*

---

*Une idée pour décorer votre maison dans un style particulièrement élégant,  
en comptant sur une large gamme de couleurs et de grands formats.*

*Une série importante qui renforce une tradition céramique de haut niveau qualitatif,  
qui dialogue en même temps avec le goût des dernières tendances en matière d'habitat.*

---

*Eine Idee, um das Zuhause in einem besonders eleganten Stil zu dekorieren, der sich  
auf eine große Auswahl an Farben und Größen stützt. Eine herausragende Serie, die  
eine hochwertige keramische Tradition festigt und gleichzeitig mit dem Geschmack der  
neuesten Wohntrends in Dialog tritt.*







# GREY SOUL

Impasto Colorato  
Colored Body  
Masse Colorée  
Durchgefärbt



45,5x45,5 cm N  
18"x18" N  
30,8x61,5 cm N  
12"x24" N  
30,4x61,0 cm R  
12"x24" R

outdoor

HIGH



**N** Naturale Natural  
**NS** Naturale/Strutturato Natural/Textured  
**R** Rettificato Rectified  
**RS** Rettificato/Strutturato Rectified/Textured

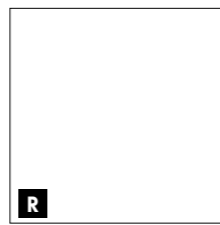

\*122,6x122,6 cm R .  
48"x48" R  
\*light, mid, dark



\*90x90 cm R . 36"x36" R  
\*light, mid, dark  
\*\*90x90 cm R - outdoor .  
36"x36" R - outdoor  
\*\*mid, dark

FP2  
pag. 346

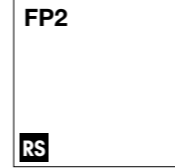

\*90x90 cm RS .  
36"x36" RS  
\*sand, mid, dark



\*80x160 cm R . 31"x62" R  
\*light, mid, dark

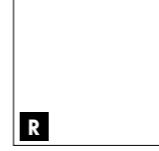

75x75 cm R .  
30"x30" R



\*61,3x122,6 cm R . 24"x48" R  
\*sand, light, mid, dark



\*45,5x45,5 cm N . 18"x18" N  
\*45,5x45,5 cm N - outdoor .  
18"x18" N - outdoor  
\*mid, dark

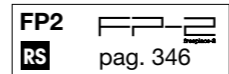

\*40x122,6 cm RS .  
16"x48" RS  
\*light, mid, dark



30,8x61,5 cm N . 12"x24" N  
30,4x61,0 cm R . 12"x24" R  
\*\*30,4x61,0 cm R . 12"x24" R  
\*\*scratch sand e light  
\*30,8x61,5 cm N - outdoor .  
12"x24" N - outdoor  
\*sand, mid, dark



61,5x61,5 cm N . 24"x24" N  
61,0x61,0 cm R . 24"x24" R  
\*61,5x61,5 cm N - outdoor .  
24"x24" N - outdoor  
\*sand, mid, dark

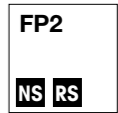

\*61,5x61,5 cm NS . 24"x24" NS  
\*61,0x61,0 cm RS . 24"x24" RS  
\*sand, light, mid, dark

FP2  
pag. 346

GREY SOUL

Per la disponibilità articolo: [www.tuscaniagres.it](http://www.tuscaniagres.it)  
digitando il codice web segnalato a lato dei formati.  
For the item's availability: [www.tuscaniagres.it](http://www.tuscaniagres.it)  
type the web code reported next to the sizes.  
Pour vérifier la disponibilité de l'article: [www.tuscaniagres.it](http://www.tuscaniagres.it)  
en saisissant le code web indiqué à coté des formats.  
Für die Artikelverfügbarkeit: [www.tuscaniagres.it](http://www.tuscaniagres.it)  
web code eingeben, an der Seite von Formaten angedeutet.

white



I6G3	75x75 cm 30"x30"	R	40,12
I9G3	61,5x61,5 cm 24"x24"	N	29,32
I1I7	61,0x61,0 cm 24"x24"	R	37,04
I2I0	30,8x61,5 cm 12"x24"	N	24,69
I7H8	30,4x61,0 cm 12"x24"	R	33,95

sand



I6G2	75x75 cm 30"x30"	R	40,12
J7M3	61,3x122,6 cm 24"x48"	R	44,75
I9G2	61,5x61,5 cm 24"x24"	N	29,32
I2I2	61,5x61,5 cm 24"x24" OUTDOOR	N	30,86
I7H6	61,0x61,0 cm 24"x24"	R	37,04
I1I9	30,8x61,5 cm 12"x24"	N	24,69
I2I1	30,8x61,5 cm 12"x24" OUTDOOR	N	26,23
I1I8	30,4x61,0 cm 12"x24"	R	33,95

FP2

L5T2	90x90 cm 36"x36" FP2	RS	74,08
I1H7	61,5x61,5 cm 24"x24" FP2	NS	55,56
I7H0	61,0x61,0 cm 24"x24" FP2	RS	67,90

scratch sand - 30,4x61,0 cm R . 12"x24" R



I3P2	30,4x61,0 cm 12"x24"	R	35,49
------	----------------------	---	-------

light



L8S9	122,6x122,6 cm 48"x48"	R	54,02
L0T2	90x90 cm 36"x36"	R	44,75
L0T5	80x160 cm 31"x62"	R	52,47
H3R8	75x75 cm 30"x30"	R	40,12
J8M2	61,3x122,6 cm 24"x48"	R	44,75
H6P5	61,5x61,5 cm 24"x24"	N	29,32
H9P6	61,0x61,0 cm 24"x24"	R	37,04
H0Q6	30,8x61,5 cm 12"x24"	N	24,69
H0Q9	30,4x61,0 cm 12"x24"	R	33,95

FP2

H3U6	61,5x61,5 cm 24"x24" FP2	NS	55,56
H3U7	61,0x61,0 cm 24"x24" FP2	RS	67,90
L8T8	40x122,6 cm 16"x48" FP2	RS	72,54

light



I3P1	30,4x61,0 cm 12"x24"	R	35,49
------	----------------------	---	-------

mid



L9S0	122,6x122,6 cm 48"x48"	R	54,02
L0T1	90x90 cm 36"x36"	R	44,75
L0T3	90x90 cm 36"x36" OUTDOOR	R	46,30
L0T6	80x160 cm 31"x62"	R	52,47
H5R5	75x75 cm 30"x30"	R	40,12
J7M8	61,3x122,6 cm 24"x48"	R	44,75
H6P6	61,5x61,5 cm 24"x24"	N	29,32
H9V9	61,5x61,5 cm 24"x24" OUTDOOR	N	30,86
H9P7	61,0x61,0 cm 24"x24"	R	37,04
I0Q5	45,5x45,5 cm 18"x18"	N	23,15
I0Q7	45,5x45,5 cm 18"x18" OUTDOOR	N	24,69
H0Q7	30,8x61,5 cm 12"x24"	N	24,69
H5U7	30,8x61,5 cm 12"x24" OUTDOOR	N	26,23
H1Q0	30,4x61,0 cm 12"x24"	R	33,95

FP2

L5T1	90x90 cm 36"x36" FP2	RS	74,08
H3U8	61,5x61,5 cm 24"x24" FP2	NS	55,56
H3U9	61,0x61,0 cm 24"x24" FP2	RS	67,90
L8T7	40x122,6 cm 16"x48" FP2	RS	72,54

dark



L9S1	122,6x122,6 cm 48"x48"	R	54,02
L0T0	90x90 cm 36"x36"	R	44,75
L0T4	90x90 cm 36"x36" OUTDOOR	R	46,30
L0T7	80x160 cm 31"x62"	R	52,47
H3R9	75x75 cm 30"x30"	R	40,12
J9M0	61,3x122,6 cm 24"x48"	R	44,75
H6P7	61,5x61,5 cm 24"x24"	N	29,32
H9V4	61,5x61,5 cm 24"x24" OUTDOOR	N	30,86
H9P5	61,0x61,0 cm 24"x24"	R	37,04
I0Q6	45,5x45,5 cm 18"x18"	N	23,15
I0Q8	45,5x45,5 cm 18"x18" OUTDOOR	N	24,69
H0Q8	30,8x61,5 cm 12"x24"	N	24,69
H5U8	30,8x61,5 cm 12"x24" OUTDOOR	N	26,23
H1Q1	30,4x61,0 cm 12"x24"	R	33,95

FP2

L5T0	90x90 cm 36"x36" FP2	RS	74,08
H4U0	61,5x61,5 cm 24"x24" FP2	NS	55,56
H4U1	61,0x61,0 cm 24"x24" FP2	RS	67,90
L8T9	40x122,6 cm 16"x48" FP2	RS	72,54



Regardez sur le site internet [www.cstb.fr](http://www.cstb.fr) s'il vous plaît

# GREY SOUL

GREY SOUL

decori - decors - décors - dekors

listello patchwork - 30,2x61,0 cm 12"x24"  **28,70/PZ**

white



sand



light



mid



dark



mosaico monocolore 36 tessere 5x5 - 30x30 cm 12"x12"  **13,27/PZ**

white



sand



light

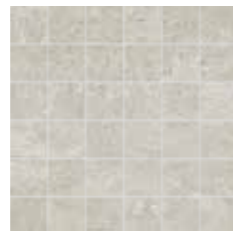

mid



dark



mosaico mix 81 tessere 3x3 - 30x30 cm 12"x12"  **13,27/PZ**

light/mid/dark



DARK | 61,5x61,5 cm N outdoor\_24"x24" N outdoor  
elemento "L" monolitico outdoor 15x61x4 cm\_6"x24"x1<sup>3/4</sup>"



pezzi speciali - special pieces -  
pièces spéciales - formteile



sand



mid



dark

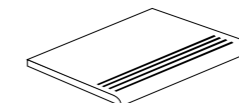

step  
30,8x61,5 cm 12"x24" **15,45/PZ**

white

sand

light

mid

dark

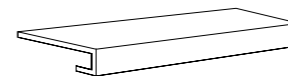

gradino costa retta   
30,5x122,6x4 cm 12"x48"x1<sup>3/4</sup>" **163,58/PZ**  
34x61,5x4 cm 13"x24"x1<sup>3/4</sup>" **83,33/PZ**

white

sand

light

mid

dark

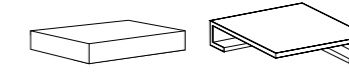

vista frontale vista dal retro  
angolare costa retta dx/sx  
30,5x122,6x4 cm 12"x48"x1<sup>3/4</sup>" **200,62/PZ**  
34x34x4 cm 13"x13"x1<sup>3/4</sup>" **103,40/PZ**

white

sand

light

mid

dark



white



sand



light



mid



dark

battiscopa   
6,5x61,5 cm 2<sup>1/2</sup>"x24" **4,78/PZ**

white

sand

light

mid

dark

Note - Notes - Notes - Anmerkungen

I battiscopa vengono venduti a pz. e a scatola completa. Tutti gli altri pezzi speciali vengono venduti al pezzo. I gradini vengono prodotti solo su ordinazione (tempo minimo di consegna 20 gg lavorativi).  
Skirtings are sold by piece and full boxes. All other special trims are sold by piece. Steps are produced only on request (minimum delivery terms of 20 days).  
Les plinthes sont vendues la pièce et par boîte complète. Les autres pièces spéciales sont vendues la pièce. Le plat de marche sont produit sur demande (délai minimum de 20 jours).  
Die Sockelleisten werden pro Stk. und Vollen Kartons verkauft. Stufen und Stufenecken werden nur auf Bestellung produziert (Lieferzeiten mindesten 20 arbeitstagen ab Auftragserteilung).

# TRAME

*Grès porcellanato smaltato*  
*Glazed porcelain stoneware . Grès cérame émaillé . Glasiertes feinsteinzeug*

*effetto cemento*  
*concrete-look*  
*effet ciment*  
*zementoptik*



*Questo progetto si esprime e si qualifica attraverso un'elevata capacità di soluzioni d'arredo derivate da una infinita gamma di potenziali trame decorative. Texture geometriche si alternano a disegni e pizzi floreali per offrire simultaneamente insolite ed affascinanti superfici coordinate pavimento- rivestimento.*

*This project comes to life through numerous decor solutions deriving from an infinite range of decorating possibilities. Geometric textures alternate with floral designs and lace to simultaneously offer unusual and fascinating coordinated floor and wall surfaces.*

*Ce projet s'exprime et se qualifie à travers son extraordinaire capacité de décor aidée par une très riche gamme de trames décoratives. Les textures géométriques s'alternent à des motifs et des dentelles de fleurs pour offrir des surfaces à la fois insolites et fascinantes, permettant de coordonner les sols et les murs.*

*Dieses Projekt qualifiziert und drückt sich durch eine hohe Fähigkeit der Einrichtungslösungen aus, die aus einem unendlichen Angebot an potentiellen dekorativen Mustern stammt. Geometrische Texturen wechseln ihre Muster und blumige Spitzen ab, um gleichzeitig ungewöhnliche, faszinierende und koordinierte Oberflächen für den Boden und Verkleidungen zu bieten.*





# TRAME mix bianco

Grès porcellanato smaltato  
Glazed porcelain stoneware  
Grès cérame émaillé  
Glasiertes Feinsteinzeug



**N** Naturale  
Natural



20x20 cm N.  
8"x8" N

juta bianco



J2S7 | 20x20 cm 8"x8" **N** 24,07

trame mix bianco



J9R9 | 20x20 cm 8"x8" **mix**

**N** 27,78

TRAME

Per la disponibilità articolo: [www.tuscaniagres.it](http://www.tuscaniagres.it) digitando il codice web segnalato a lato dei formati.  
For the item's availability: [www.tuscaniagres.it](http://www.tuscaniagres.it) type the web code reported next to the sizes.  
Pour vérifier la disponibilité de l'article: [www.tuscaniagres.it](http://www.tuscaniagres.it) en saisissant le code web indiqué à côté des formats.  
Für die Artikelverfügbarkeit: [www.tuscaniagres.it](http://www.tuscaniagres.it) web code eingeben, an der Seite von Formaten angedeutet.

MIX BIANCO | 20x20 cm N\_8"x8" N - JUTAGRIGIO | 20x20 cm N\_8"x8" N



# TRAME mix grigio

Grès porcellanato smaltato  
Glazed porcelain stoneware  
Grès cérame émaillé  
Glasiertes Feinsteinzeug

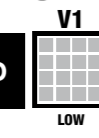

**N** Naturale  
Natural



20x20 cm N.  
8"x8" N



juta grigio



JOT2 | 20x20 cm 8"x8" **N** 24,07

wall: DAMIER BIANCO | 20x20 cm N\_8"x8" N  
MIX GRIGIO | 20x20 cm N\_8"x8" N  
floor: DAMIER BIANCO | 20x20 cm N\_8"x8" N

# TRAME

Per la disponibilità articolo: [www.tuscaniagres.it](http://www.tuscaniagres.it) digitando il codice web segnalato a lato dei formati.  
For the item's availability: [www.tuscaniagres.it](http://www.tuscaniagres.it) type the web code reported next to the sizes.  
Pour vérifier la disponibilité de l'article: [www.tuscaniagres.it](http://www.tuscaniagres.it) en saisissant le code web indiqué à côté des formats.  
Für die Artikelverfügbarkeit: [www.tuscaniagres.it](http://www.tuscaniagres.it) web code eingeben, an der Seite von Formaten angedeutet.

trame mix grigio



JOS1 | 20x20 cm 8"x8" **mix**

**N** 27,78

# TRAME mix color

Grès porcellanato smaltato  
Glazed porcelain stoneware  
Grès cérame émaillé  
Glasiertes Feinsteinzeug

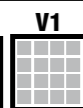

**N** Naturale  
Natural

juta bianco



J2S7 | 20x20 cm 8"x8" **N** 24,07

juta grigio

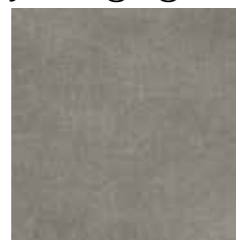

J0T2 | 20x20 cm 8"x8" **N** 24,07

trame mix color



J0S0 | 20x20 cm N 8"x8" N **mix**

**N** 27,78

## TRAME

Per la disponibilità articolo: [www.tuscaniagres.it](http://www.tuscaniagres.it) digitando il codice web segnalato a lato dei formati.  
For the item's availability: [www.tuscaniagres.it](http://www.tuscaniagres.it) type the web code reported next to the sizes.  
Pour vérifier la disponibilité de l'article: [www.tuscaniagres.it](http://www.tuscaniagres.it) en saisissant le code web indiqué à côté des formats.  
Für die Artikelverfügbarkeit: [www.tuscaniagres.it](http://www.tuscaniagres.it) web code eingeben, an der Seite von Formaten angedeutet.

MAKÒ COLOR - MIX COLOR | 20x20 cm N\_8"x8" N

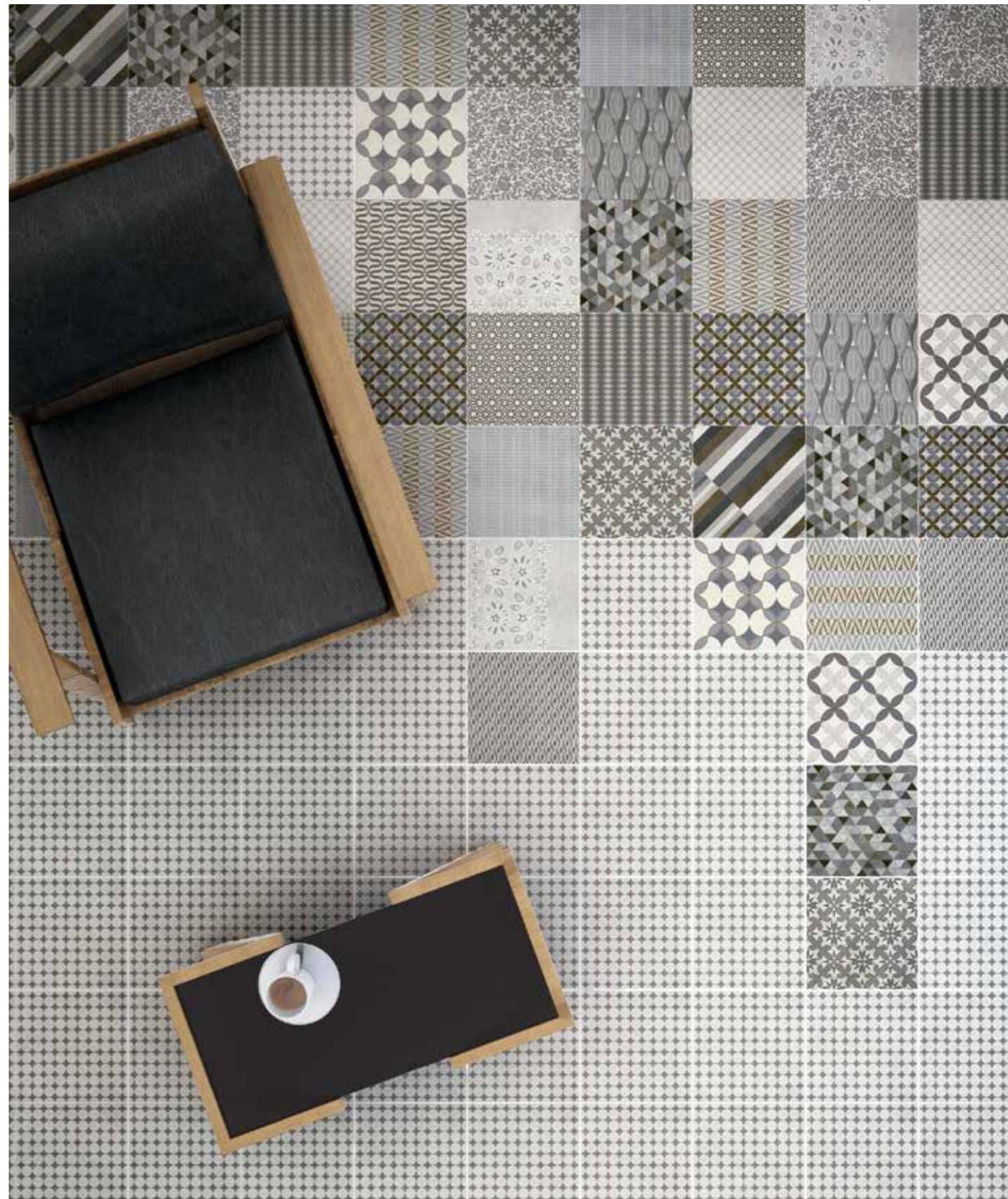

# TRAME monofaccia grigio

Grès porcellanato smaltato  
Glazed porcelain stoneware  
Grès cérame émaillé  
Glasiertes Feinsteinzeug

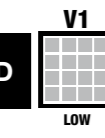

**N** Naturale  
Natural



20x20 cm N.  
8"x8" N

juta bianco



J2S7 | 20x20 cm 8"x8" **N** 24,07

juta grigio



J0T2 | 20x20 cm 8"x8" **N** 24,07

damier bianco

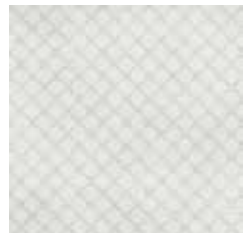

J5T3 | 20x20 cm 8"x8" **N** 27,78

damier grigio

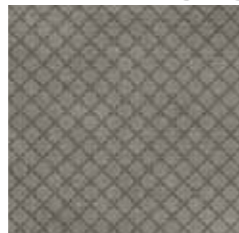

J9S9 | 20x20 cm 8"x8" **N** 27,78

clip grigio



J9S8 | 20x20 cm 8"x8" **N** 27,78

makò grigio

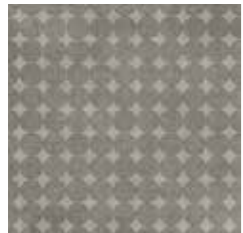

J5T7 | 20x20 cm 8"x8" **N** 27,78

tulip grigio

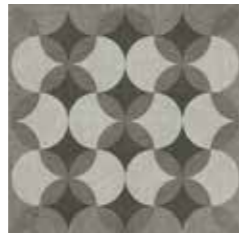

J7S7 | 20x20 cm 8"x8" **N** 27,78

iris grigio

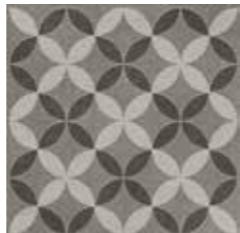

J2S5 | 20x20 cm 8"x8" **N** 27,78

TRAME  
Per la disponibilità articolo: [www.tuscaniagres.it](http://www.tuscaniagres.it) digitando il codice web segnalato a lato dei formati.  
For the item's availability: [www.tuscaniagres.it](http://www.tuscaniagres.it) type the web code reported next to the sizes.  
Pour vérifier la disponibilité de l'article: [www.tuscaniagres.it](http://www.tuscaniagres.it) en saisissant le code web indiqué à côté des formats.  
Für die Artikelverfügbarkeit: [www.tuscaniagres.it](http://www.tuscaniagres.it) web code eingeben, an der Seite von Formaten angedeutet.

JUTA GRIGIO - IRIS GRIGIO - MAKÒ GRIGIO - TULIP GRIGIO - DAMIER GRIGIO | 20x20 cm N\_8"x8" N

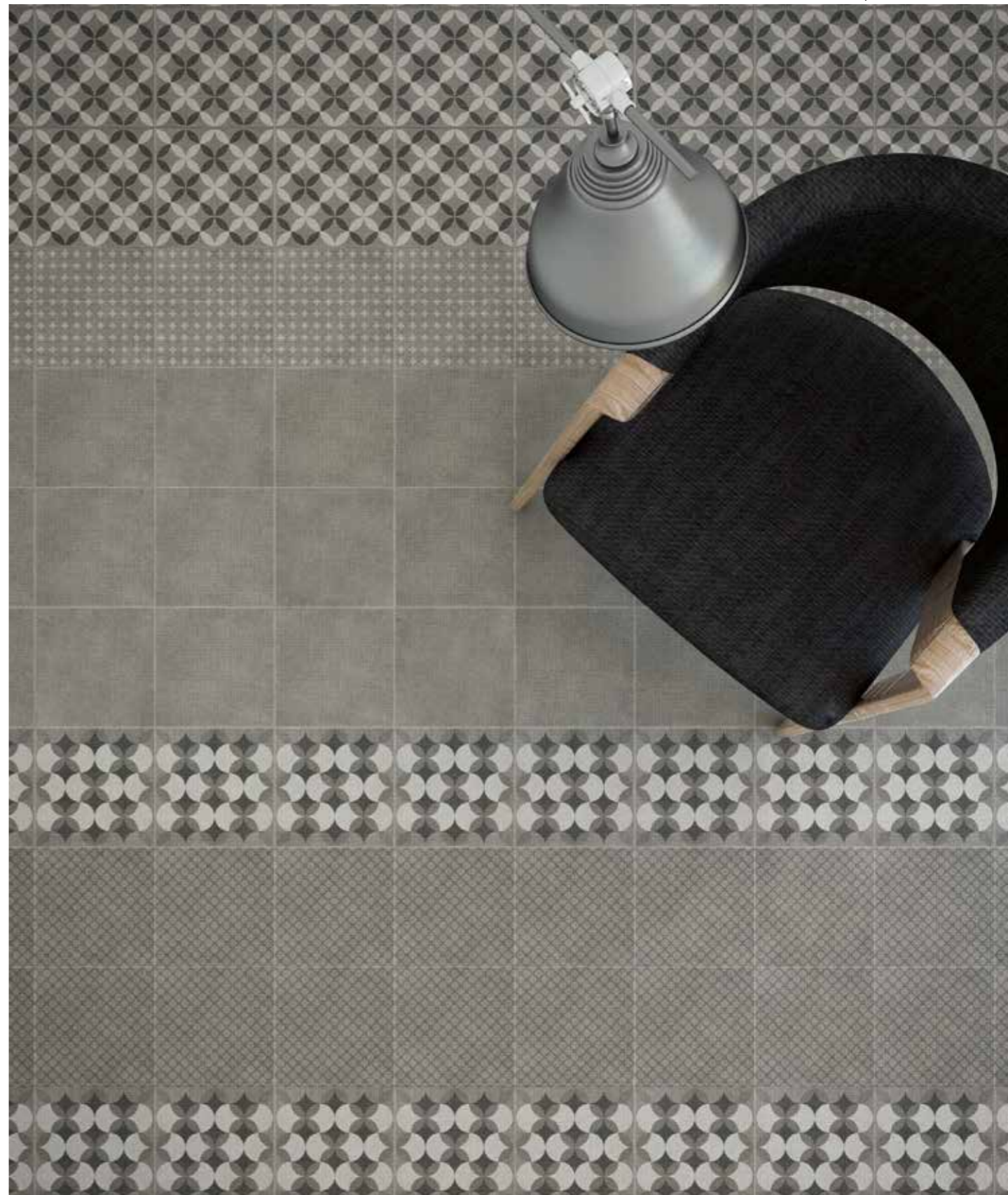



# TRAME monofaccia color

Grès porcellanato smaltato  
Glazed porcelain stoneware  
Grès cérame émaillé  
Glasiertes Feinsteinzeug

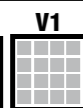

**N** Naturale  
Natural



20x20 cm N.  
8"x8" N

juta bianco



J2S7 | 20x20 cm 8"x8" **N** 24,07

juta grigio



J0T2 | 20x20 cm 8"x8" **N** 24,07

damier color



J5T4 | 20x20 cm 8"x8" **N** 27,78

clip color



J5T0 | 20x20 cm 8"x8" **N** 27,78

makò color

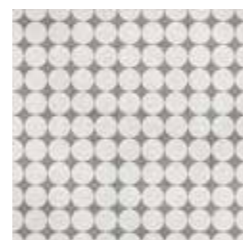

J0T3 | 20x20 cm 8"x8" **N** 27,78

tulip color



J2S6 | 20x20 cm 8"x8" **N** 27,78

iris color



J3S9 | 20x20 cm 8"x8" **N** 27,78

TRAME  
Per la disponibilità articolo: [www.tuscaniagres.it](http://www.tuscaniagres.it) digitando il codice web segnalato a lato dei formati.  
For the item's availability: [www.tuscaniagres.it](http://www.tuscaniagres.it) type the web code reported next to the sizes.  
Pour vérifier la disponibilité de l'article: [www.tuscaniagres.it](http://www.tuscaniagres.it) en saisissant le code web indiqué à côté des formats.  
Für die Artikelverfügbarkeit: [www.tuscaniagres.it](http://www.tuscaniagres.it) web code eingeben, an der Seite von Formaten angegeben.  
wall: JUTA BIANCO - TULIP COLOR - IRIS COLOR - MAKÒ COLOR | 20x20 cm N\_8"x8" N  
floor: DECAPÉ MORO | 20,3x122,6 cm R\_8"x48" R



# BASIC

*Grès porcellanato smaltato*  
*Glazed porcelain stoneware . Grès cérame émaillé . Glasiertes Feinsteinzeug*

*effetto cemento*  
*concrete-look*  
*effet ciment*  
*zementoptik*



*Trentasei texture geometriche diverse fra loro,  
definiscono un pattern decorativo intenso e colorato.  
Cerchi, quadrati, rettangoli e rombi si alternano e si incastrano tra loro  
per definire una trama fitta e regolare a tratti optical, ma sempre calda e  
piacevole, i cui toni dominanti sono a volte caldi ed a volte più freddi.*

*Thirty-six different geometrical textures defining an intense, coloured decorative pattern.  
Circles, squares, rectangles and diamonds alternate and fit together to define a thick,  
regular weave with optical, yet always warm and pleasing features,  
the dominant colours of which are now warm, now colder.*

*Trente-six textures géométriques différentes les unes des autres  
définissent un motif décoratif intense et coloré.  
Des cercles, des carrés, des rectangles et des losanges alternent et s'encastrent  
les uns dans les autres afin de définir une trame dense et régulière à effet d'optique,  
mais toujours chaude et agréable, et dont les tonalités dominantes  
sont tantôt chaudes, tantôt plus froides.*

*Sechsenddreißig verschiedene geometrische Strukturen  
definieren ein intensives und farbenfrohes Dekor.  
Kreise, Quadrate, Rechtecke und Rauten wechseln sich ab und fügen sich zu einer dichten  
und regelmäßigen Textur zusammen, manchmal im Optical-Stil, aber immer warm und  
angenehm, wobei die dominanten Töne manchmal warm und manchmal kühler sind.*



# BASIC

Grès porcellanato smaltato  
Glazed porcelain stoneware  
Grès cérame émaillé  
Glasiertes Feinsteinzeug

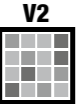

MIX  
61,0x61,0 cm R  
24"x24" R

**N** Naturale  
Natural

cold



I3N2 | 20x20 cm 8"x8" **N** [24,07]

warm



I3N3 | 20x20 cm 8"x8" **N** [24,07]

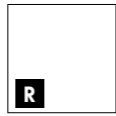

61,0x61,0 cm R  
24"x24" R  
mix



20x20 cm N . 8"x8" N

BASIC  
Per la disponibilità articolo: [www.tuscaniagres.it](http://www.tuscaniagres.it) digitando il codice web segnalato a lato dei formati.  
For the item's availability: [www.tuscaniagres.it](http://www.tuscaniagres.it) type the web code reported next to the sizes.  
Pour vérifier la disponibilité de l'article: [www.tuscaniagres.it](http://www.tuscaniagres.it) en saisissant le code web indiqué à côté des formats.  
Für die Artikelverfügbarkeit: [www.tuscaniagres.it](http://www.tuscaniagres.it) web code eingeben, an der Seite von Formaten angedeutet.

decori - decors - décors - dekors

decori - decors - décors - dekors

decoro mix



I0M3 | 20x20 cm 8"x8" **N** [27,78]

decoro mix



I9H1 | 61,0x61,0 cm 24"x24" **R** [46,30]

# ETERNITY

*Grès porcellanato smaltato*  
*Glazed porcelain stoneware . Grès cérame émaillé . Glasiertes Feinsteinzeug*

*effetto cemento*  
*concrete-look*  
*effet ciment*  
*zementoptik*



*Una serie infinita di cadenze che esaltano i diversi toni di grigio, perfettamente coordinati tra loro, attraverso la rappresentazione di decori dal sapore nostalgico e di altri tempi.*

*Anche il fondo di riferimento sembra collegarsi al passato mantenendo rigorosamente la stessa cromia delle formelle decorate.*

*An infinite, rhythmic series enhancing the many shades of grey, all perfectly coordinated, through the representation of decorations with the nostalgic flavour of yesteryear.*

*Even the base colour seems to have links with the past, keeping strictly to the same colours of the decorated tiles.*

*Une série infinie de cadences qui exaltent les différents tons de gris, parfaitement assortis entre eux, à travers la représentation de décorations à la saveur nostalgique et d'autres époques.*

*Le fond de référence semble lui aussi évoquer le passé en conservant rigoureusement la même tonalité que celle des carreaux décorés.*

*Eine unendliche Reihe von Rhythmen, die die verschiedenen Grautöne zur Geltung bringen, sie sind durch die Darstellung von nostalgischen und Vintage- Dekorationen perfekt aufeinander abgestimmt.*  
*Auch die dazugehörige Grundfliese steht ganz im Zeichen des Vintage-Flairs und ist in genau denselben Farben wie die dekorierten Fliesen erhältlich.*



# ETERNITY

Grès porcellanato smaltato  
Glazed porcelain stoneware  
Grès cérame émaillé  
Glasiertes Feinsteinzeug



**N** Naturale  
Natural

eternity



J1Q3 | 20x20 cm 8"x8" **N** 24,07



20x20 cm N . 8"x8" N

decori - decors - décors - dekors

eternity mix



J6Q1 | 20x20 cm 8"x8" **mix**

**N** 27,78

# ETERNITY

Per la disponibilità articolo: [www.tuscaniagres.it](http://www.tuscaniagres.it) digitando il codice web segnalato a lato dei formati.  
For the item's availability: [www.tuscaniagres.it](http://www.tuscaniagres.it) type the web code reported next to the sizes.  
Pour vérifier la disponibilité de l'article: [www.tuscaniagres.it](http://www.tuscaniagres.it) en saisissant le code web indiqué à côté des formats.  
Für die Artikelverfügbarkeit: [www.tuscaniagres.it](http://www.tuscaniagres.it) web code eingeben, an der Seite von Formaten angedeutet.

ETERNITY | 20x20 cm N\_8"x8" N - ETERNITY MIX | 20x20 cm N\_8"x8" N



# CAROCIMENT

*Grès porcellanato smaltato*  
*Glazed porcelain stoneware . Grès cérame émaillé . Glasiertes feinsteinzeug*

*effetto cemento*  
*concrete-look*  
*effet ciment*  
*zementoptik*



*Ecco il ritorno delle classiche “Cementine” perfettamente riproposte in tutto il loro splendore nelle grafiche e nei colori. Sedici formelle diverse ma tematicamente coordinate tra loro per creare inediti campi decorati sulle pareti di ambienti sia pubblici che privati.*

*The return to the classic “Cementine” tiles, reposed in all the splendour of their patterns and colours. Sixteen different tiles with coordinated patterns to create unique decorated fields on the walls of both public and private settings.*

*Voici le retour des “Cementine” classiques, parfaitement repropoées dans toute leur splendeur dans les graphismes et les couleurs. Seize carreaux différents mais coordonnés entre eux du point de vue de la thématique afin de créer d’inédits champs décorés sur les murs d’espaces aussi bien publics que privés.*

*Dies ist die Rückkehr der klassischen “Cementine” in ihrer ganzen Pracht, was die grafische und farbliche Gestaltung angeht. Sechzehn verschiedene, aber thematisch aufeinander abgestimmte Fliesen, mit denen ganz neuartige Dekorbereiche an den Wänden öffentlicher und privater Räume geschaffen werden können.*



# CAROCIMENT

Grès porcellanato smaltato  
Glazed porcelain stoneware  
Grès cérame émaillé  
Glasiertes Feinsteinzeug



V1



LOW  
gris, beige

V4



RANDOM  
mix



**N** Naturale  
Natural

gris



J7N3 | 20x20 cm 8"x8" **N** 24,07

beige



J8N2 | 20x20 cm 8"x8" **N** 24,07

decori - decors - décors - dekors

\*carociment mix



18V9 | 20x20 cm 8"x8" **mix**

**N** 27,78



20x20 cm N . 8"x8" N

# CAROCIMENT

Per la disponibilità articolo: [www.tuscaniagres.it](http://www.tuscaniagres.it) digitando il codice web segnalato a lato dei formati.  
For the item's availability: [www.tuscaniagres.it](http://www.tuscaniagres.it) type the web code reported next to the sizes.  
Pour vérifier la disponibilité de l'article: [www.tuscaniagres.it](http://www.tuscaniagres.it) en saisissant le code web indiqué à côté des formats.  
Für die Artikelverfügbarkeit: [www.tuscaniagres.it](http://www.tuscaniagres.it) web code eingeben, an der Seite von Formaten angedeutet.

wall: MIX | 20x20 cm N\_8"x8" N - floor: GREY SOUL MID | 75x75 cm R\_30"x30" R



\* La tonalità del materiale è da ritenersi puramente indicativa. - Please consider the shades of material as indicative only.  
La tonalité du matériel est tout à fait indicative. - Farbabweichungen sind möglich und können deshalb nicht beanstandet werden.

# AGADIR

*Grès porcellanato smaltato*  
*Glazed porcelain stoneware . Grès cérame émaillé . Glasiertes feinsteinzeug*

*effetto cemento*  
*concrete-look*  
*effet ciment*  
*zementoptik*



*Figure geometriche stilizzate si alternano armoniosamente per comporre tavolozze cromatiche calde e familiari. Il fondo, che si ispira alla pergamena antica, ne sottolinea l'esotismo rendendolo gradevole e gioiosamente abitabile.*

*Stylised geometrical figures alternate harmoniously to create warm, familiar colour palettes. The base, inspired by antiqued parchment, underlines the exotic appeal, making it pleasantly, joyfully livable.*

*Des figures géométriques stylisées alternent harmonieusement pour composer des palettes chromatiques chaudes et familières. Le fond, qui s'inspire d'un parchemin vieilli, en souligne l'exotisme en le rendant agréable et joyeusement habitable.*

*Stilisierte geometrische Figuren wechseln sich auf harmonische Weise miteinander ab und bilden warme und vertraute Farbpaletten. Die vom antiken Pergament inspirierte Grundfliese unterstreicht die exotische Wirkung und macht das Gesamtbild ausgesprochen wohnlich und fröhlich.*





# AGADIR

Grès porcellanato smaltato  
Glazed porcelain stoneware  
Grès cérame émaillé  
Glasiertes Feinsteinzeug



R9

HD

V2



MODERATE  
bianco

V4



RANDOM  
mix



WALL



FLOOR



20x20 cm N . 8"x8" N

**N** Naturale  
Natural

bianco



J9J8 | 20x20 cm 8"x8" **N** | 24,07

decori - decors - décors - dekors

agadir mix



J9J7 | 20x20 cm 8"x8" **mix**

**N** | 27,78

decoro monofaccia - 20x20 cm 8"x8"

fiordaliso



J1V9 | 20x20 cm 8"x8" **N** | 27,78

stella alpina



J1V8 | 20x20 cm 8"x8" **N** | 27,78

viola blu



L4R2 | 20x20 cm 8"x8" **N** | 27,78

giglio nero



L4R1 | 20x20 cm 8"x8" **N** | 27,78

# AGADIR

Per la disponibilità articolo: [www.tuscaniagres.it](http://www.tuscaniagres.it) digitando il codice web segnalato a lato dei formati.  
For the item's availability: [www.tuscaniagres.it](http://www.tuscaniagres.it) type the web code reported next to the sizes.  
Pour vérifier la disponibilité de l'article: [www.tuscaniagres.it](http://www.tuscaniagres.it) en saisissant le code web indiqué à côté des formats.  
Für die Artikelverfügbarkeit: [www.tuscaniagres.it](http://www.tuscaniagres.it) web code eingeben, an der Seite von Formaten angedeutet.

MIX | 20x20 cm N\_8"x8" N

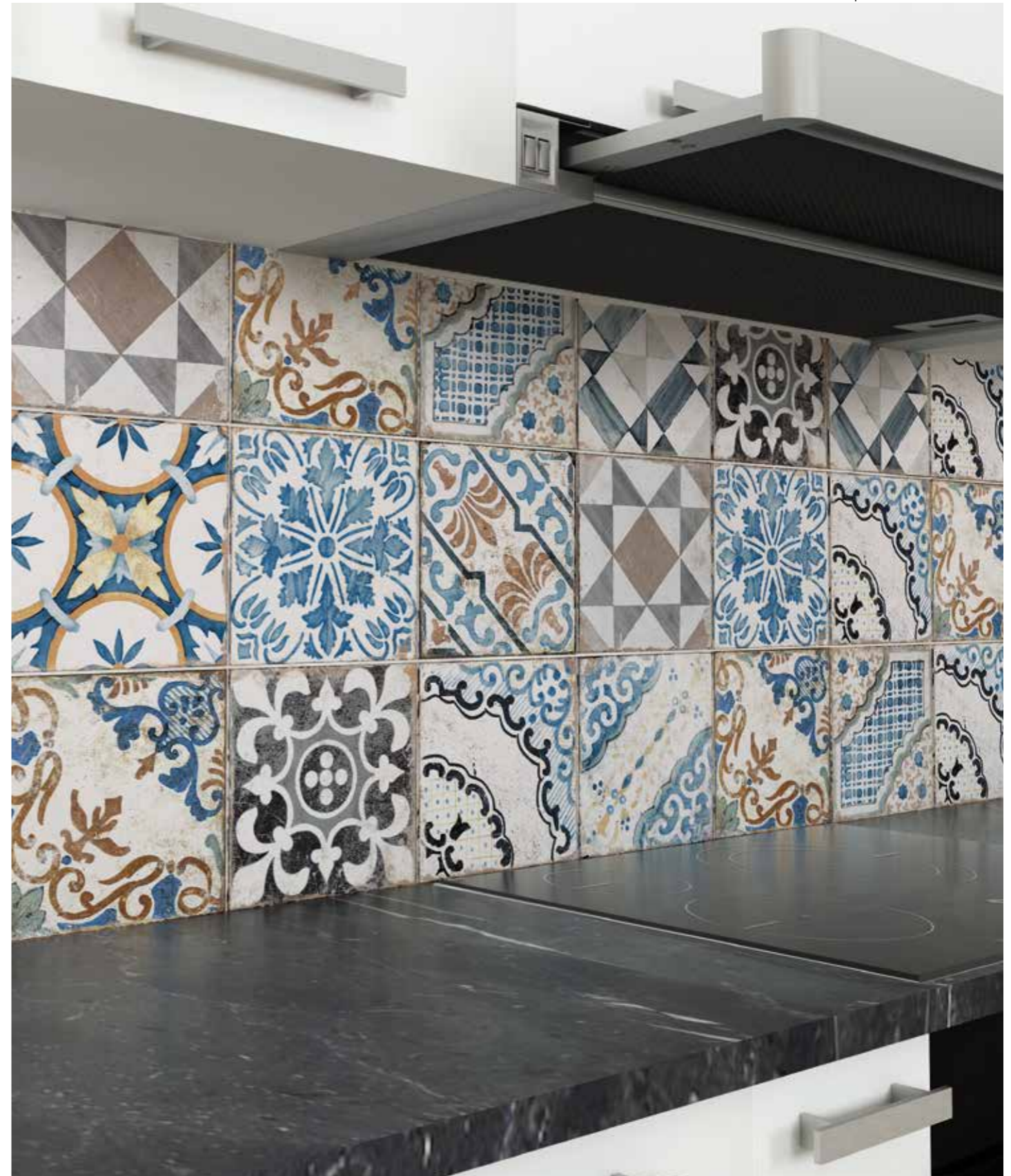

effetto pietra  
stone-look . effet pierre . steinoptik



Bricks	196
Cor-Stone	160
Durango	164
Edelweiss	170
Etruria	174
Limestone	130
Pierre Bleue	144
Quarzo	192
Sparkly	188
Terraforte	182
Tomahawk	152
Tribeca	136

*Grès porcellanato*  
*Porcelain stoneware*  
*Grès cérame coloré*  
*Feinsteinzeug*

  
**TUSCANIA**  
ceramiche

# LIMESTONE

*Grès porcellanato impasto colorato*  
*Color body porcelain stoneware . Grès cérame coloré dans la masse . Durchgefärbtes Feinsteinzeug*

*effetto pietra*  
*stone-look*  
*effet pierre*  
*steinoptik*



*Movimenti morbidi di materia vera si intrecciano a venature più o meno accentuate nel definire una pietra di particolare interesse estetico. Una speciale tecnologia digitale valorizza il prodotto definendo innumerevoli superfici tutte diverse fra loro che concorrono a comporre spazi sempre diversi ma ugualmente belli e sorprendenti.*

*Soft movements and textures entwine with vein markings that are more or less prominent to define a particularly interesting stone effect.*

*The product is enhanced by a special digital technology, defining countless surfaces that are all different and*

*used together to create spaces that are always different but just as beautiful and amazing.*

*Des mouvements souples de matière véritable s'entrecroisent à des veinures plus ou moins accentuées pour définir une pierre au singulier intérêt esthétique.*

*Une technologie numérique spéciale met en valeur le produit en définissant d'innombrables surfaces toutes distinctes les unes des autres qui participent à la composition d'espaces toujours différents mais chacun d'eux beau et surprenant à la fois.*

*Weiche Bewegungen aus echtem Material verflechten sich mit mehr oder weniger akzentuierten Äderungen und definieren so einen Naturstein von besonderem ästhetischem Wert.*

*Eine spezielle Digitaltechnik veredelt das Produkt, das unzählige unterschiedliche Oberflächen definiert, die dazu beitragen, Räume zu schaffen, die immer wieder anders, aber ebenso schön und überraschend sind.*



# LIMESTONE

Impasto Colorato  
Colored Body  
Masse Colorée  
Durchgefärbt



30,4x61,0 cm R  
12"x24" R

**R** Rettificato  
Rectified

**RS** Rettificato/Strutturato  
Rectified/Textured

## LIMESTONE

Per la disponibilità articolo: [www.tuscaniagres.it](http://www.tuscaniagres.it)  
digitando il codice web segnalato a lato dei formati.  
For the item's availability: [www.tuscaniagres.it](http://www.tuscaniagres.it)  
type the web code reported next to the sizes.  
Pour vérifier la disponibilité de l'article: [www.tuscaniagres.it](http://www.tuscaniagres.it)  
en saisissant le code web indiqué à coté des formats.  
Für die Artikelverfügbarkeit: [www.tuscaniagres.it](http://www.tuscaniagres.it)  
web code eingeben, an der Seite von Formaten angedeutet.

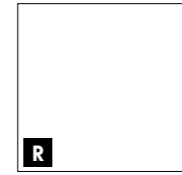

90x90 cm R . 36"x36" R

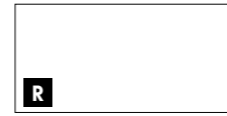

61,3x122,6 cm R . 24"x48" R

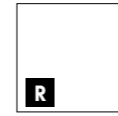

61,0x61,0 cm R .  
24"x24" R

FP2  
pag. 342

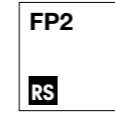

\*61,0x61,0 cm RS .  
24"x24" RS  
\*coal, beige, ash



30,4x61,0 cm R .  
12"x24" R

## ice



L3W6	90x90 cm 36"x36"	<b>R</b>	44,75
L4W0	61,3x122,6 cm 24"x48"	<b>R</b>	44,75
L3W2	61,0x61,0 cm 24"x24"	<b>R</b>	37,04
L4W4	30,4x61,0 cm 12"x24"	<b>R</b>	33,95

## coal



L3W8	90x90 cm 36"x36"	<b>R</b>	44,75
L4W2	61,3x122,6 cm 24"x48"	<b>R</b>	44,75
L3W4	61,0x61,0 cm 24"x24"	<b>R</b>	37,04
L4W6	30,4x61,0 cm 12"x24"	<b>R</b>	33,95

FP2

L5W9	61,0x61,0 cm 24"x24" FP2	<b>RS</b>	67,90
------	--------------------------	-----------	-------

## beige



L3W9	90x90 cm 36"x36"	<b>R</b>	44,75
L4W3	61,3x122,6 cm 24"x48"	<b>R</b>	44,75
L3W5	61,0x61,0 cm 24"x24"	<b>R</b>	37,04
L4W7	30,4x61,0 cm 12"x24"	<b>R</b>	33,95

FP2

L4W9	61,0x61,0 cm 24"x24" FP2	<b>RS</b>	67,90
------	--------------------------	-----------	-------

## ash



L3W7	90x90 cm 36"x36"	<b>R</b>	44,75
L4W1	61,3x122,6 cm 24"x48"	<b>R</b>	44,75
L3W3	61,0x61,0 cm 24"x24"	<b>R</b>	37,04
L4W5	30,4x61,0 cm 12"x24"	<b>R</b>	33,95

FP2

L8X9	61,0x61,0 cm 24"x24" FP2	<b>RS</b>	67,90
------	--------------------------	-----------	-------

# LIMESTONE

LIMESTONE

decori - decors - décors - dekors

mosaico monocolore 36 tessere 5x5 - 30x30 cm 12"x12"  13,27/PZ

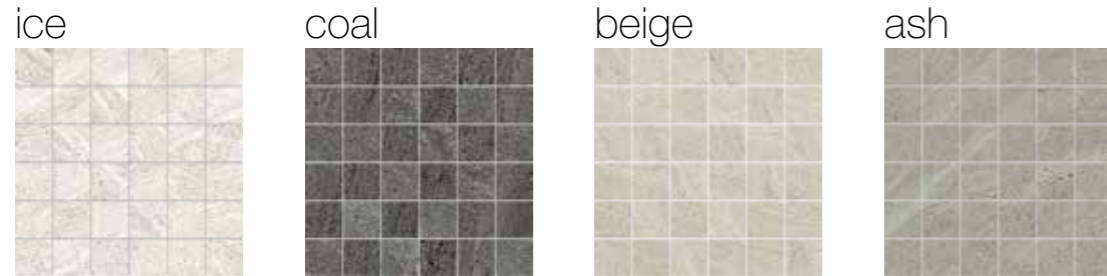

mosaico asimmetrico 18 pz - 30x30 cm 12"x12"  13,27/PZ



pezzi speciali - special pieces - pièces spéciales - formteile



battiscopa  **4,78/PZ**  
 6,5x61,0 cm R 2 1/2"x24" R  
 ice \_\_\_\_\_  
 coal \_\_\_\_\_  
 beige \_\_\_\_\_  
 ash \_\_\_\_\_

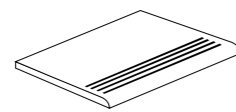

step  
 30,4x61,0 cm 12"x24" **15,45/PZ**

ice \_\_\_\_\_  
 coal \_\_\_\_\_  
 beige \_\_\_\_\_  
 ash \_\_\_\_\_

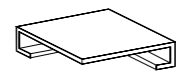
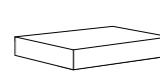

vista frontale  
 angolare costa retta dx/sx  
 30,5x122,6x4 cm 12"x48"x1 3/4" **200,62/PZ**  
 34x34x4 cm 13"x13"x1 3/4" **103,40/PZ**

ice \_\_\_\_\_  
 coal \_\_\_\_\_  
 beige \_\_\_\_\_  
 ash \_\_\_\_\_

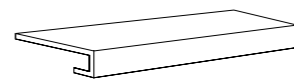

gradino costa retta   
 30,5x122,6x4 cm 12"x48"x1 3/4" **163,58/PZ**  
 34x61,0x4 cm 13"x24"x1 3/4" **83,33/PZ**

ice \_\_\_\_\_  
 coal \_\_\_\_\_  
 beige \_\_\_\_\_  
 ash \_\_\_\_\_

Note - Notes - Notes - Anmerkungen

I battiscopa vengono venduti a pz. e a scatola completa. Tutti gli altri pezzi speciali vengono venduti al pezzo. I gradini vengono prodotti solo su ordinazione (tempo minimo di consegna 20 gg lavorativi).  
 Skirtings are sold by piece and full boxes. All other special trims are sold by piece. Steps are produced only on request (minimum delivery terms of 20 days).  
 Les plinthes sont vendues la pièce et par boîte complète. Les autres pièces spéciales sont vendus la pièce. Le plat de marche sont produit sur demande (délai minimum de 20 jours).  
 Die Sockelleisten werden pro Stk. und Vollen Kartons verkauft. Stufen und Stufenecken werden nur auf Bestellung produziert (Lieferzeiten mindesten 20 arbeitstagen ab Auftragserteilung).

COAL | 61,0x61,0 cm R\_24"x24" R



# TRIBECA

*Grès porcellanato impasto colorato*  
*Color body porcelain stoneware . Grès cérame coloré dans la masse . Durchgefärbtes Feinsteinzeug*

*effetto pietra*  
*stone-look*  
*effet pierre*  
*steinoptik*



*Questa serie rappresenta un grande progetto articolato su quattro colori base la cui superficie ricalca la finezza e l'eleganza della pietra a spacco. Si avvale inoltre di accessori di alto pregio quali i mosaici esagonali ed i mosaici a tessere pluridimensionali. Perfettamente in linea con l'ultima generazione ceramica, che presta particolare attenzione agli spazi esterni, questo materiale vuole essere il protagonista indiscusso non solo delle superfici interne ma anche di quelle esterne sia pubbliche che private.*

*This series is an important project made up of four base colours, with a surface that replicas the fineness and elegance of split stone. It also combines other high-class elements, such as hexagonal mosaics and mosaics with tesserae of different dimensions. Perfectly in line with the latest generation of ceramic products that focus largely on outdoor spaces, this material aims to be the undisputed star not only for indoor surfaces but also outside, in both public spaces and outside the home.*

*Cette série représente un grand projet articulé sur quatre couleurs de base dont la surface reprend la finesse et l'élégance de la pierre fendue. Elle fait appel en outre à des accessoires de haute valeur comme les mosaïques hexagonales et les mosaïques à tesselles pluridimensionnelles. Parfaitement en accord avec la dernière génération céramique, qui accorde une attention particulière aux espaces extérieurs, ce matériau se veut le protagoniste incontesté non seulement des surfaces intérieures mais aussi extérieures qu'elles soient publiques ou privées*

*Diese Serie stellt ein umfassendes Projekt dar. Das Material ist in vier Grundfarben erhältlich, deren Oberflächen die Finesse und Eleganz von Spaltstein nachahmen. Darüber hinaus wird hochwertiges Zubehör wie sechseckige Mosaïke und mehrdimensionale Mosaikfliesen verwendet. Ganz im Sinne der neuesten Generation von Keramik, die dem Außenraum besondere Aufmerksamkeit schenkt, ist dieses Material nicht nur in Innenräumen ein Blickfang, sondern auch in öffentlichen und privaten Außenbereichen.*





# TRIBECA

Impasto Colorato  
Colored Body  
Masse Colorée  
Durchgefärbt



**NS** Naturale/Strutturato  
Natural/Textured

**RS** Rettificato/Strutturato  
Rectified/Textured

## TRIBECA

Per la disponibilità articolo: [www.tuscaniagres.it](http://www.tuscaniagres.it)  
digitando il codice web segnalato a lato dei formati.  
For the item's availability: [www.tuscaniagres.it](http://www.tuscaniagres.it)  
type the web code reported next to the sizes.  
Pour vérifier la disponibilité de l'article: [www.tuscaniagres.it](http://www.tuscaniagres.it)  
en saisissant le code web indiqué à coté des formats.  
Für die Artikelverfügbarkeit: [www.tuscaniagres.it](http://www.tuscaniagres.it)  
web code eingeben, an der Seite von Formaten angedeutet.

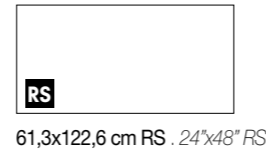

61,3x122,6 cm RS . 24"x48" RS



61,5x61,5 cm NS .  
24"x24" NS  
61,0x61,0 cm RS.  
24"x24" RS



30,8x61,5 cm NS .  
12"x24" NS  
30,8x61,5 cm NS - outdoor.  
12"x24" NS - outdoor  
30,4x61,0 cm RS .  
12"x24" RS



15,1x30,6 cm NS - outdoor.  
6"x12" NS - outdoor

white



L6W1	61,5x61,5 cm 24"x24"	NS	29,32
L8N1	61,3x122,6 cm 24"x48"	RS	44,75
L5W7	61,0x61,0 cm 24"x24"	RS	37,04
J1W7	30,8x61,5 cm 12"x24"	NS	24,69
L1W8	30,8x61,5 cm 12"x24" OUTDOOR	NS	26,23
L8K9	30,4x61,0 cm 12"x24"	RS	33,95
L1W2	15,1x30,6 cm 6"x12" OUTDOOR	NS	25,62

grey



L6W2	61,5x61,5 cm 24"x24"	NS	29,32
L8N0	61,3x122,6 cm 24"x48"	RS	44,75
L5W6	61,0x61,0 cm 24"x24"	RS	37,04
J1W8	30,8x61,5 cm 12"x24"	NS	24,69
L1W7	30,8x61,5 cm 12"x24" OUTDOOR	NS	26,23
L8K8	30,4x61,0 cm 12"x24"	RS	33,95
L1W3	15,1x30,6 cm 6"x12" OUTDOOR	NS	25,62

dark grey



L6W3	61,5x61,5 cm 24"x24"	NS	29,32
L7N9	61,3x122,6 cm 24"x48"	RS	44,75
L5W5	61,0x61,0 cm 24"x24"	RS	37,04
J1W9	30,8x61,5 cm 12"x24"	NS	24,69
L2W0	30,8x61,5 cm 12"x24" OUTDOOR	NS	26,23
L8K7	30,4x61,0 cm 12"x24"	RS	33,95
L1W6	15,1x30,6 cm 6"x12" OUTDOOR	NS	25,62

beige



L6W0	61,5x61,5 cm 24"x24"	NS	29,32
L6W7	61,3x122,6 cm 24"x48"	RS	44,75
L5W3	61,0x61,0 cm 24"x24"	RS	37,04
J6W4	30,8x61,5 cm 12"x24"	NS	24,69
L6W6	30,8x61,5 cm 12"x24" OUTDOOR	NS	26,23
L6W5	30,4x61,0 cm 12"x24"	RS	33,95
L1W1	15,1x30,6 cm 6"x12" OUTDOOR	NS	25,62



# TRIBECA

TRIBECA

decori - decors - décors - dekors

indoor: DARK GREY | 61,0x61,0 cm RS\_24"x24" RS  
 outdoor: DARK GREY | 30,4x61,0 cm RS outdoor\_12"x24" RS outdoor

mosaico esagona - 30x30 cm 12"x12"

 16,67/PZ

white

grey

dark grey

beige



mosaico basket - 30x30 cm 12"x12"

tessere: 2,3x2,3 . 1"x1" - 2,3x4,8 . 1"x2" - 4,8x4,8 . 2"x2" - 4,8x7,3 . 2"x3"  21,91/PZ

white

grey

dark grey

beige



mosaico monocolore 36 tessere 5x5 - 30x30 cm 12"x12"  13,27/PZ

white

grey

dark grey

beige

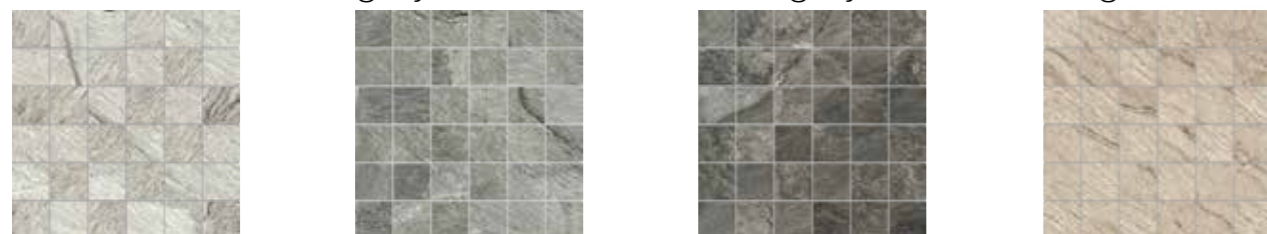

pezzi speciali - special pieces - pièces spéciales - fornteile

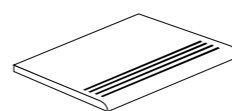

step  
30,8x61,5 cm 12"x24" **15,45/PZ**

white  
grey  
dark grey  
beige

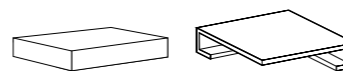

vista frontale      vista dal retro  
angolare costa retta dx/sx  
30,5x122,6x4 cm 12"x48"x1<sup>3/4</sup>" **200,62/PZ**  
34x34x4 cm 13"x13"x1<sup>3/4</sup>" **103,40/PZ**

white  
grey  
dark grey  
beige



white      grey  
dark grey      beige  
elemento "L" monolitico outdoor  
15x30x4 cm 6"x12"x1<sup>3/4</sup>" **10,80/PZ**

white  
grey  
dark grey  
beige



gradino costa retta   
30,5x122,6x4 cm 12"x48"x1<sup>3/4</sup>" **163,58/PZ**  
34x61,5x4 cm 13"x24"x1<sup>3/4</sup>" **83,33/PZ**

white  
grey  
dark grey  
beige



battiscopa   
6,5x61,5 cm 2<sup>1/2</sup>"x24" **4,78/PZ**

white  
grey  
dark grey  
beige

Note - Notes - Notes - Anmerkungen

I battiscopa vengono venduti a pz. e a scatola completa. Tutti gli altri pezzi speciali vengono venduti al pezzo. I gradini vengono prodotti solo su ordinazione (tempo minimo di consegna 20 gg lavorativi).  
 Skirtings are sold by piece and full boxes. All other special trims are sold by piece. Steps are produced only on request (minimum delivery terms of 20 days).  
 Les plinthes sont vendues la pièce et par boîte complète. Les autres pièces spéciales sont vendus la pièce. Le plat de marche sont produit sur demande (délai minimum de 20 jours).  
 Die Sockelleisten werden pro Stk. und Vollen Kartons verkauft. Stufen und Stufenecken werden nur auf Bestellung produziert (Lieferzeiten mindesten 20 arbeitstagen ab Auftragserteilung).

# PIERRE BLEUE

---

*Grès porcellanato impasto colorato*  
*Color body porcelain stoneware . Grès cérame coloré dans la masse . Durchgefärbtes Feinsteinzeug*

*effetto pietra*  
*stone-look*  
*effet pierre*  
*steinoptik*



*Il termine di paragone è una pietra naturale che attraverso l'usura dei secoli acquista forza, fascino e bellezza. Si tratta di una rappresentazione autentica, raffinata e geniale, frutto di un'evoluzione tecnologica esclusiva che riproduce alla perfezione l'essenza tradizionale di una pietra nobile.*

---

*Inspired by natural stone that acquires strength, allure and beauty through centuries of wear. An authentic, refined and ingenious representation coming from an exclusive technological evolution that beautifully replicates the traditional essence of noble stone.*

*La matière de comparaison est une pierre naturelle sur laquelle les signes d'usure laissés au fil des siècles deviennent force, charme et beauté.*

*Il s'agit d'une réplique authentique, raffinée et géniale, fruit d'une évolution technologique exclusive reproduisant à la perfection l'essence légendaire d'une pierre noble.*

*Die Inspiration für diese Kollektion ist ein Naturstein, der dank der jahrhundertelangen Abnutzung Kraft, Faszination und Schönheit erworben hat.*

*Es handelt sich um eine authentische, elegante und geniale Darstellung, das Ergebnis einer exklusiven technologischen Entwicklung, welche die traditionelle Essenz eines edlen Steins widerspiegelt.*





GLACE | 75x75 R\_30"x30" R

-CG\_146-

PIERRE BLEUE

floor: FONCÉ | 61,0x61,0 cm R\_24"x24" R  
wall: BRICKS CLASSIC | 37,5x75 cm R\_15"x30" R



-CG\_147-

# PIERRE BLEUE

Impasto Colorato  
Colored Body  
Masse Colorée  
Durchgefärbt



V3



HIGH

30,4x61,0 cm R  
12"x24" R

**NS** Naturale/Strutturato  
Natural/Textured

**R** Rettificato  
Rectified

**RS** Rettificato/Strutturato  
Rectified/Textured

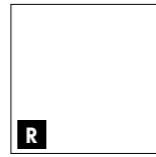

75x75 cm R . 30"x30" R



61,0x61,0 cm R .  
24"x24" R

FP2  
pag. 352

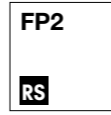

\*61,0x61,0 cm RS . 24"x24" RS  
\*clair, foncé, antique



30,4x61,0 cm R . 12"x24" R

## PIERRE BLEUE

Per la disponibilità articolo: [www.tuscaniagres.it](http://www.tuscaniagres.it)  
digitando il codice web segnalato a lato dei formati.  
For the item's availability: [www.tuscaniagres.it](http://www.tuscaniagres.it)  
type the web code reported next to the sizes.  
Pour vérifier la disponibilité de l'article: [www.tuscaniagres.it](http://www.tuscaniagres.it)  
en saisissant le code web indiqué à coté des formats.  
Für die Artikelverfügbarkeit: [www.tuscaniagres.it](http://www.tuscaniagres.it)  
web code eingeben, an der Seite von Formaten angedeutet.

glace



L2S6	75x75 cm 30"x30"	R	40,12
L0Q0	61,0x61,0 cm 24"x24"	R	37,04
L9P5	30,4x61,0 cm 12"x24"	R	33,95

clair



J7Q4	75x75 cm 30"x30"	R	40,12
J5S4	61,0x61,0 cm 24"x24"	R	37,04
L9P7	30,4x61,0 cm 12"x24"	R	33,95

FP2

L1U7	61,0x61,0 cm 24"x24" FP2	RS	67,90
------	--------------------------	----	-------

foncé



J7Q5	75x75 cm 30"x30"	R	40,12
J5S5	61,0x61,0 cm 24"x24"	R	37,04
L9P4	30,4x61,0 cm 12"x24"	R	33,95

FP2

L1U8	61,0x61,0 cm 24"x24" FP2	RS	67,90
------	--------------------------	----	-------

antique



J1U6	75x75 cm 30"x30"	R	40,12
J5S6	61,0x61,0 cm 24"x24"	R	37,04
L9P9	30,4x61,0 cm 12"x24"	R	33,95

FP2

J2Q7	61,0x61,0 cm 24"x24" FP2	RS	67,90
------	--------------------------	----	-------

CLAIR| 75x75 R\_30"x30" R



# PIERRE BLEUE

PIERRE BLEUE

decori - decors - décors - dekors

indoor: FONCÉ | 61,0x61,0 cm R\_24"x24" R  
 outdoor: ANTIQUE FP2 | 61,5x61,5 cm NS\_24"x24" NS

mosaico brick - 15x60 cm 6"x24"  28,70/PZ

glace



clair



foncé



antique



pezzi speciali - special pieces - pièces spéciales - formteile



glace



clair



foncé



antique

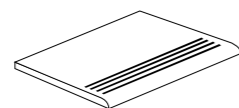

step  
 30,4x61,0 cm R 12"x24" R  15,45/PZ



glace

clair

foncé

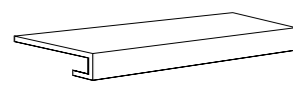
antique



gradino costa retta    
 34x61,0x4 cm 13"x24"x1 3/4"  83,33/PZ

glace

clair

foncé

antique

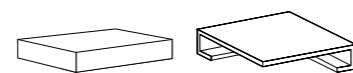



vista frontale      vista dal retro  
 angolare costa retta dx/sx  
 34x34x4 cm 13"x13"x1 3/4"  103,40/PZ

glace

clair

foncé

antique

battiscopa     
 6,5x61,0 cm R 2 1/2"x24" R  4,78/PZ

glace

clair

foncé

antique

Note - Notes - Notes - Anmerkungen

I battiscopa vengono venduti a pz. e a scatola completa. Tutti gli altri pezzi speciali vengono venduti al pezzo. I gradini vengono prodotti solo su ordinazione (tempo minimo di consegna 20 gg lavorativi).  
 Skirtings are sold by piece and full boxes. All other special trims are sold by piece. Steps are produced only on request (minimum delivery terms of 20 days).  
 Les plinthes sont vendues la pièce et par boîte complète. Les autres pièces spéciales sont vendus la pièce. Le plat de marche sont produit sur demande (délai minimum de 20 jours).  
 Die Sockelleisten werden pro Stk. und Vollen Kartons verkauft. Stufen und Stufenecken werden nur auf Bestellung produziert (Lieferzeiten mindesten 20 arbeitstagen ab Auftragserteilung).



# TOMAHAWK

*Grès porcellanato smaltato*  
*Glazed porcelain stoneware . Grès cérame émaillé . Glasiertes Feinsteinzeug*

*effetto pietra*  
*stone-look*  
*effet pierre*  
*steinoptik*



*Un' accentuata ma assolutamente voluta stonalizzazione rappresenta il valore aggiunto della serie Tomahawk. La superficie ceramica si qualifica con forte originalità miscelando in modo suggestivo sia tonalità forti e profonde che nuances più chiare proprio per ottenere un risultato di contrasto poli sensoriale. In questo caso il canone estetico cerca volutamente una frattura, sia nella continuità cromatica che superficiale, per definirne un carattere singolare ed inedito.*

*The faded colour effects of this collection are strong and absolutely intentional and are the added value of the Tomahawk series.*

*The ceramic surface is highly original and obtained by carefully mixing together strong, deep tones alongside lighter nuances, with the very aim of obtaining a very strong contrast.*

*In this case, the objective is to obtain a true fracture, both in the colours used and the texture, making this product boldly different and totally unusual.*

*Une stonatisation accentuée mais absolument voulue constitue la valeur ajoutée de la série Tomahawk.*

*La surface céramique se distingue par sa forte originalité mêlant de manière suggestive à la fois des tonalités fortes et profondes et des nuances plus claires afin d'obtenir un résultat de contraste multi-sensoriel.*

*Ici, le canon esthétique recherche délibérément une fracture, dans la continuité chromatique comme dans celle de surface, pour en définir un caractère singulier et inédit.*

*Der Mehrwert der Tomahawk-Serie ist eine akzentuierte, aber absolut bewusste Farbschattierung. Die Keramikoberfläche zeichnet sich durch eine besondere Originalität aus, die auf suggestive Weise sowohl intensive und dunkle als auch hellere Farbtöne vermischt, um als Ergebnis einen poly-sensorischen Kontrast zu erzielen. In diesem Fall bricht der ästhetische Kanon bewusst sowohl mit der chromatischen als auch mit der oberflächlichen Kontinuität, um einen einzigartigen und beispiellosen Charakter zu definieren.*





# TOMAHAWK

Grès porcellanato smaltato  
Glazed porcelain stoneware  
Grès cérame émaillé  
Glasiertes Feinsteinzeug

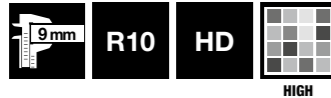

**N** Naturale  
Natural

**R** Rettificato  
Rectified

## almond



<b>J1W3</b>	30,8x61,5 cm 12"x24"	<b>N</b>	<b>24,69</b>
<b>L9K2</b>	30,4x61,0 cm 12"x24"	<b>R</b>	<b>33,95</b>
<b>L8W0</b>	10x30 cm 4"x12"	<b>R</b>	<b>55,56</b>

## blue



<b>L5M5</b>	45,5x45,5 cm 18"x18"	<b>N</b>	<b>23,15</b>
<b>J1W1</b>	30,8x61,5 cm 12"x24"	<b>N</b>	<b>24,69</b>
<b>L9K3</b>	30,4x61,0 cm 12"x24"	<b>R</b>	<b>33,95</b>
<b>L3R9</b>	10x30 cm 4"x12"	<b>R</b>	<b>55,56</b>

## white



<b>L5M8</b>	45,5x45,5 cm 18"x18"	<b>N</b>	<b>23,15</b>
<b>J1W4</b>	30,8x61,5 cm 12"x24"	<b>N</b>	<b>24,69</b>
<b>L9K6</b>	30,4x61,0 cm 12"x24"	<b>R</b>	<b>33,95</b>
<b>L4R0</b>	10x30 cm 4"x12"	<b>R</b>	<b>55,56</b>

## grey



<b>L5M7</b>	45,5x45,5 cm 18"x18"	<b>N</b>	<b>23,15</b>
<b>J1W2</b>	30,8x61,5 cm 12"x24"	<b>N</b>	<b>24,69</b>
<b>L9K5</b>	30,4x61,0 cm 12"x24"	<b>R</b>	<b>33,95</b>
<b>L3R8</b>	10x30 cm 4"x12"	<b>R</b>	<b>55,56</b>

## charcoal

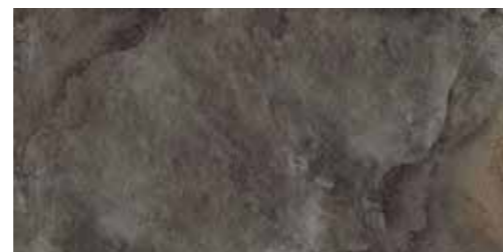

<b>L5M6</b>	45,5x45,5 cm 18"x18"	<b>N</b>	<b>23,15</b>
<b>J1W0</b>	30,8x61,5 cm 12"x24"	<b>N</b>	<b>24,69</b>
<b>L9K4</b>	30,4x61,0 cm 12"x24"	<b>R</b>	<b>33,95</b>
<b>L3R7</b>	10x30 cm 4"x12"	<b>R</b>	<b>55,56</b>



\*45,5x45,5 cm N  
18"x18" N  
\*white, grey,  
blue, charcoal



30,8x61,5 cm N . 12"x24" N  
30,4x61,0 cm R . 12"x24" R



10x30 cm R .  
4"x12" R

# TOMAHAWK

Per la disponibilità articolo: [www.tuscaniagres.it](http://www.tuscaniagres.it)  
digitando il codice web segnalato a lato dei formati.  
For the item's availability: [www.tuscaniagres.it](http://www.tuscaniagres.it)  
type the web code reported next to the sizes.  
Pour vérifier la disponibilité de l'article: [www.tuscaniagres.it](http://www.tuscaniagres.it)  
en saisissant le code web indiqué à côté des formats.  
Für die Artikelverfügbarkeit: [www.tuscaniagres.it](http://www.tuscaniagres.it)  
web code eingeben, an der Seite von Formaten angedeutet.

sviluppo grafico . design development

## white



## blue





# TOMAHAWK

TOMAHAWK

CHARCOAL | 30,4x61,0 cm R\_12"x24" R - elemento "L" monolitico 15x61x4 cm\_6"x24"x1<sup>3</sup>/<sub>4</sub>"

decori - decors - décors - dekors

mosaico esagona - 30x30 cm 12"x12"  **16,67/PZ**



mosaico monocolor 36 tessere 5x5 - 30x30 cm 12"x12"  **13,27/PZ**



mosaico basket - 30x30 cm 12"x12"  
tessere: 2,3x2,3 . 1"x1" - 2,3x4,8 . 1"x2" - 4,8x4,8 . 2"x2" - 4,8x7,3 . 2"x3"  **21,91/PZ**



pezzi speciali - special pieces - pièces spéciales - formteile



Note - Notes - Notes - Anmerkungen  
I battiscopa vengono venduti a pz. e a scatola completa. Tutti gli altri pezzi speciali vengono venduti al pezzo. I gradini vengono prodotti solo su ordinazione (tempo minimo di consegna 20 gg lavorativi).  
Skirtings are sold by piece and full boxes. All other special trims are sold by piece. Steps are produced only on request (minimum delivery terms of 20 days).  
Les plinthes sont vendues la pièce et par boîte complète. Les autres pièces spéciales sont vendus la pièce. Le plat de marche sont produit sur demande (délai minimum de 20 jours).  
Die Sockelleisten werden pro Stk. und Vollen Kartons verkauft. Stufen und Stufenecken werden nur auf Bestellung produziert (Lieferzeiten mindesten 20 arbeitstagen ab Auftragserteilung).

# COR-STONE

*Grès porcellanato impasto colorato*  
*Color body porcelain stoneware . Grès cérame coloré dans la masse . Durchgefärbtes Feinsteinzeug*

*effetto pietra*  
*stone-look*  
*effet pierre*  
*steinoptik*

GREY    DARK



*Tanta materia pregiata, disponibile anche in alto spessore.  
Consigliata per la paviamentazione di aree esterne ed interne,  
sia pubbliche sia private, questa linea di prodotti non ha limiti  
nelle più diverse destinazioni d'uso.*

*Un materiale indistruttibile, idoneo per tutti i tipi di posa,  
tradizionali come a secco.*

*So much precious material, also available in a high thickness.  
For indoor and outdoor floors in both public and private spaces,  
these tiles have unlimited uses and applications. An indestructible material  
suitable for all types of installations, from traditional laying to dry laying.*

*Une abondance de matière de grande valeur,  
disponible aussi en épaisseur majorée.  
Une ligne de produits conseillée pour revêtir les sols extérieurs et intérieurs,  
aussi bien dans le secteur public que privé, aucun domaine d'application ne  
lui est interdit. Un matériau indestructible,  
adapté à tous les types de pose, traditionnels ou à sec.*

*Eine sehr wertvolle Materie, die auch in einer höheren Stärke erhältlich ist.  
Für Außen- und Innenböden in der Öffentlichkeit und privat geeignet:  
Diese Produktserie hat innerhalb verschiedener Einsatzmöglichkeiten keine  
Limits. Ein unzerstörbares Material, das für alle traditionellen  
wie Trocken-Verlegungsarten geeignet ist.*



# COR-STONE

Impasto Colorato  
Colored Body  
Masse Colorée  
Durchgefärbt



**NS** Naturale/Strutturato  
Natural/Textured

**RS** Rettificato/Strutturato  
Rectified/Textured

FP2  
pag. 354

FP2  
pag. 354

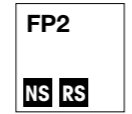

\* 61,5x61,5 cm NS .  
24"x24" NS  
\* 61,0x61,0 cm RS.  
24"x24" RS  
\*dark

\*40x122,6 cm RS .  
16"x48" RS  
\*dark

30,8x61,5 cm NS . 12"x24" NS  
30,8x61,5 cm NS **outdoor**.  
12"x24" NS **outdoor**  
30,4x61,0 cm RS . 12"x24" RS

grey



L3J5	30,8x61,5 cm 12"x24"	NS	24,69
L3J6	30,8x61,5 cm 12"x24" OUTDOOR	NS	26,23
L9K1	30,4x61,0 cm 12"x24"	RS	33,95

dark



L3J4	30,8x61,5 cm 12"x24"	NS	24,69
J9V7	30,8x61,5 cm 12"x24" OUTDOOR	NS	26,23
J9Q0	30,4x61,0 cm 12"x24"	RS	33,95

FP2

L7R0	61,5x61,5 cm 24"x24" FP2	NS	55,56
L7R1	61,0x61,0 cm 24"x24" FP2	RS	67,90
L2U1	40x122,6 cm 16"x48" FP2	RS	72,54

pezzi speciali - special pieces - pièces spéciales - formteile



battiscopa **R** **12**  
6,5x61,5 cm 2 1/2"x24" **4,78/PZ**  
grey  
dark



elemento "L" monolitico outdoor  
15x61x4 cm 6"x24"x1 3/4" **33,95/PZ**  
grey  
dark



dark

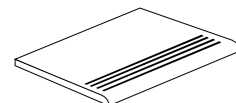

step  
30,8x61,5 cm 12"x24" **15,45/PZ**  
grey  
dark

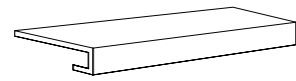

gradino costa retta **12**  
30,8x61,5x4 cm 12"x24"x1 3/4" **83,33/PZ**  
grey  
dark

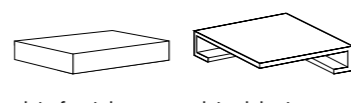

vista frontale vista dal retro  
angolare costa retta dx/sx  
30,8x30,8x4 cm 12"x12"x1 3/4" **103,40/PZ**  
grey  
dark

Note - Notes - Notes - Anmerkungen

I battiscopa vengono venduti a pz. e a scatola completa. Tutti gli altri pezzi speciali vengono venduti al pezzo. I gradini vengono prodotti solo su ordinazione (tempo minimo di consegna 20 gg lavorativi).  
Skirtings are sold by piece and full boxes. All other special trims are sold by piece. Steps are produced only on request (minimum delivery terms of 20 days).  
Les plinthes sont vendues la pièce et par boîte complète. Les autres pièces spéciales sont vendus la pièce. Le plat de marche sont produit sur demande (délai minimum de 20 jours).  
Die Sockelleisten werden pro Stk. und Vollen Kartons verkauft. Stufen und Stufenecken werden nur auf Bestellung produziert (Lieferzeiten mindesten 20 arbeitstagen ab Auftragserteilung).

## COR-STONE

Per la disponibilità articolo: [www.tuscaniagres.it](http://www.tuscaniagres.it)  
digitando il codice web segnalato a lato dei formati.  
For the item's availability: [www.tuscaniagres.it](http://www.tuscaniagres.it)  
type the web code reported next to the sizes.  
Pour vérifier la disponibilité de l'article: [www.tuscaniagres.it](http://www.tuscaniagres.it)  
en saisissant le code web indiqué à coté des formats.  
Für die Artikelverfügbarkeit: [www.tuscaniagres.it](http://www.tuscaniagres.it)  
web code eingeben, an der Seite von Formaten angedeutet.

DARK FP2 | 61,5x61,5 cm NS\_24"x24" NS



# DURANGO

---

*Grès porcellanato impasto colorato*  
*Color body porcelain stoneware . Grès cérame coloré dans la masse . Durchgefärbtes Feinsteinzeug*

*effetto pietra*  
*stone-look*  
*effet pierre*  
*steinoptik*



*Una pietra esotica che ci riporta  
ai colori delle rocce dei deserti messicani.  
Pietre color ocra, avana e bruno che rasenta il fulvo  
per conferire personalità e carattere alle nostre abitazioni  
seguendo un gusto inconsueto ed originale.*

*An exotic stone that evokes  
the colours of rocks in the Mexican deserts.  
Stones in the shades of ochre, havana and brown, verging on fawn  
to give our homes personality and character  
following an unusual, original taste.*

*Une pierre exotique qui nous ramène  
aux couleurs des roches des déserts mexicains.  
Pierres de couleur ocra, havane et brune qui confine au fauve  
Pour apporter personnalité et caractère à nos habitations  
en adoptant un goût inhabituel et original.*

*Ein exotischer Stein, der an die Farben  
der Felsen der mexikanischen Wüsten erinnern.  
Ocker, Havanna und Braun mit rötlichem Charakter,  
um unseren Wohnungen Persönlichkeit und Charakter zu verleihen,  
die einem ungewöhnlichen und originellen Geschmack folgen.*



# DURANGO

Impasto Colorato  
Colored Body  
Masse Colorée  
Durchgefärbt

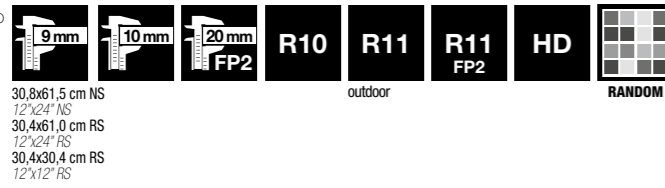

**NS** Naturale/Strutturato - Natural/Textured  
**RS** Rettificato/Strutturato - Rectified/Textured



75x75 cm RS .  
30"x30" RS



61,5x61,5 cm NS .  
24"x24" NS  
61,0x61,0 cm RS .  
24"x24" RS



pag. 356

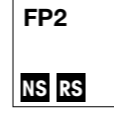

\*61,5x61,5 cm NS .  
24"x24" NS  
\*61,0x61,0 cm RS .  
24"x24" RS  
\*medium



30,8x61,5 cm NS . 12"x24" NS  
30,4x61,0 cm RS . 12"x24" RS  
\*30,8x61,5 cm NS outdoor.  
12"x24" NS outdoor  
\*walnut, grey, medium



30,4x30,4 cm RS .  
12"x12" RS

DURANGO  
Per la disponibilità articolo: [www.tuscaniagres.it](http://www.tuscaniagres.it)  
digitando il codice web segnalato a lato dei formati.  
For the item's availability: [www.tuscaniagres.it](http://www.tuscaniagres.it)  
type the web code reported next to the sizes.  
Pour vérifier la disponibilité de l'article: [www.tuscaniagres.it](http://www.tuscaniagres.it)  
en saisissant le code web indiqué à côté des formats.  
Für die Artikelverfügbarkeit: [www.tuscaniagres.it](http://www.tuscaniagres.it)  
web code eingeben, an der Seite von Formaten angedeutet.

## medium



H3Y7	75x75 cm 30"x30"	RS	40,12
H1X4	61,5x61,5 cm 24"x24"	NS	29,32
H1X8	61,0x61,0 cm 24"x24"	RS	37,04
H0X2	30,8x61,5 cm 12"x24"	NS	24,69
J4M4	30,8x61,5 cm 12"x24" OUTDOOR	NS	26,23
H0X6	30,4x61,0 cm 12"x24"	RS	33,95
H1X0	30,4x30,4 cm 12"x12"	RS	38,58

J0Q0	61,5x61,5 cm 24"x24" FP2	NS	55,56
I4Z2	61,0x61,0 cm 24"x24" FP2	RS	67,90

## walnut



H4Y0	75x75 cm 30"x30"	RS	40,12
H1X7	61,5x61,5 cm 24"x24"	NS	29,32
H2X1	61,0x61,0 cm 24"x24"	RS	37,04
H0X5	30,8x61,5 cm 12"x24"	NS	24,69
I9Q5	30,8x61,5 cm 12"x24" OUTDOOR	NS	26,23
H0X9	30,4x61,0 cm 12"x24"	RS	33,95
H1X3	30,4x30,4 cm 12"x12"	RS	38,58

## washed



H3Y8	75x75 cm 30"x30"	RS	40,12
H1X5	61,5x61,5 cm 24"x24"	NS	29,32
H1X9	61,0x61,0 cm 24"x24"	RS	37,04
H0X3	30,8x61,5 cm 12"x24"	NS	24,69
H0X7	30,4x61,0 cm 12"x24"	RS	33,95
H1X1	30,4x30,4 cm 12"x12"	RS	38,58

## grey



H3Y9	75x75 cm 30"x30"	RS	40,12
H1X6	61,5x61,5 cm 24"x24"	NS	29,32
H2X0	61,0x61,0 cm 24"x24"	RS	37,04
H0X4	30,8x61,5 cm 12"x24"	NS	24,69
I9Q6	30,8x61,5 cm 12"x24" OUTDOOR	NS	26,23
H0X8	30,4x61,0 cm 12"x24"	RS	33,95
H1X2	30,4x30,4 cm 12"x12"	RS	38,58

# DURANGO

DURANGO

decori - decors - décors - dekors

mosaico 36 tessere 5x5 - 30x30 cm 12"x12"  13,27/PZ



mosaico basket - 30x30 cm 12"x12"  
tessere: 2,3x2,3 . 1"x1" - 2,3x4,8 . 1"x2" - 4,8x4,8 . 2"x2" - 4,8x7,3 . 2"x3"  21,91/PZ



pezzi speciali - special pieces - pièces spéciales - formteile



Note - Notes - Notes - Anmerkungen

I battiscopa vengono venduti a pz. e a scatola completa. Tutti gli altri pezzi speciali vengono venduti al pezzo. I gradini vengono prodotti solo su ordinazione (tempo minimo di consegna 20 gg lavorativi).  
Skirtings are sold by piece and full boxes. All other special trims are sold by piece. Steps are produced only on request (minimum delivery terms of 20 days).  
Les plinthes sont vendues la pièce et par boîte complète. Les autres pièces spéciales sont vendus la pièce. Le plat de marche sont produit sur demande (délai minimum de 20 jours).  
Die Sockelleisten werden pro Stk. und Vollen Kartons verkauft. Stufen und Stufenecken werden nur auf Bestellung produziert (Lieferzeiten mindesten 20 arbeitstagen ab Auftragserteilung).

MEDIUM | 61,0x61,0 cm RS\_24"x24" RS



# EDELWEISS

*Grès porcellanato impasto colorato*

*Color body porcelain stoneware . Grès cérame coloré dans la masse . Durchgefärbtes Feinsteinzeug*

*effetto pietra  
stone-look  
effet pierre  
steinoptik*



*Una superficie materica leggermente variegata, percorsa da leggere venature, interpreta la contemporaneità della pietra naturale che da sempre sta alla base delle architetture dell'uomo.*

*Una linea definita da quattro tonalità calde, ma soprattutto autentiche e naturali, che sanno trasmettere agli ambienti una personalità ed un carattere moderno e senza tempo.*

*A slightly variegated texture with light vein markings reflects the contemporary quality of natural stone, which has always been a fundamental aspect of architecture.*

*This line is defined by four shades that are warm but above all authentic and natural, and have the ability to fill a room with personality and a timelessly modern character.*

*Une surface matérique légèrement hétérogène, parcourue de légères veinures, interprète la modernité de la pierre naturelle qui, depuis toujours, est à la base des architectures humaines.*

*Une ligne définie par quatre tonalités chaudes, mais avant tout authentiques et naturelles, qui savent conférer aux espaces une personnalité et un caractère moderne et intemporel.*

*Eine leicht gesprenkelte, mit hellen Adern bedeckte Oberfläche mit Materialoptik, interpretiert den zeitgenössischen Stil von Natursteinen, die schon immer die Grundlage der menschlichen Architektur waren.  
Eine Linie von vier warmen, aber vor allem authentischen und natürlichen Farbtönen, die den Räumen eine moderne und zeitlose Persönlichkeit und Charakter verleihen.*

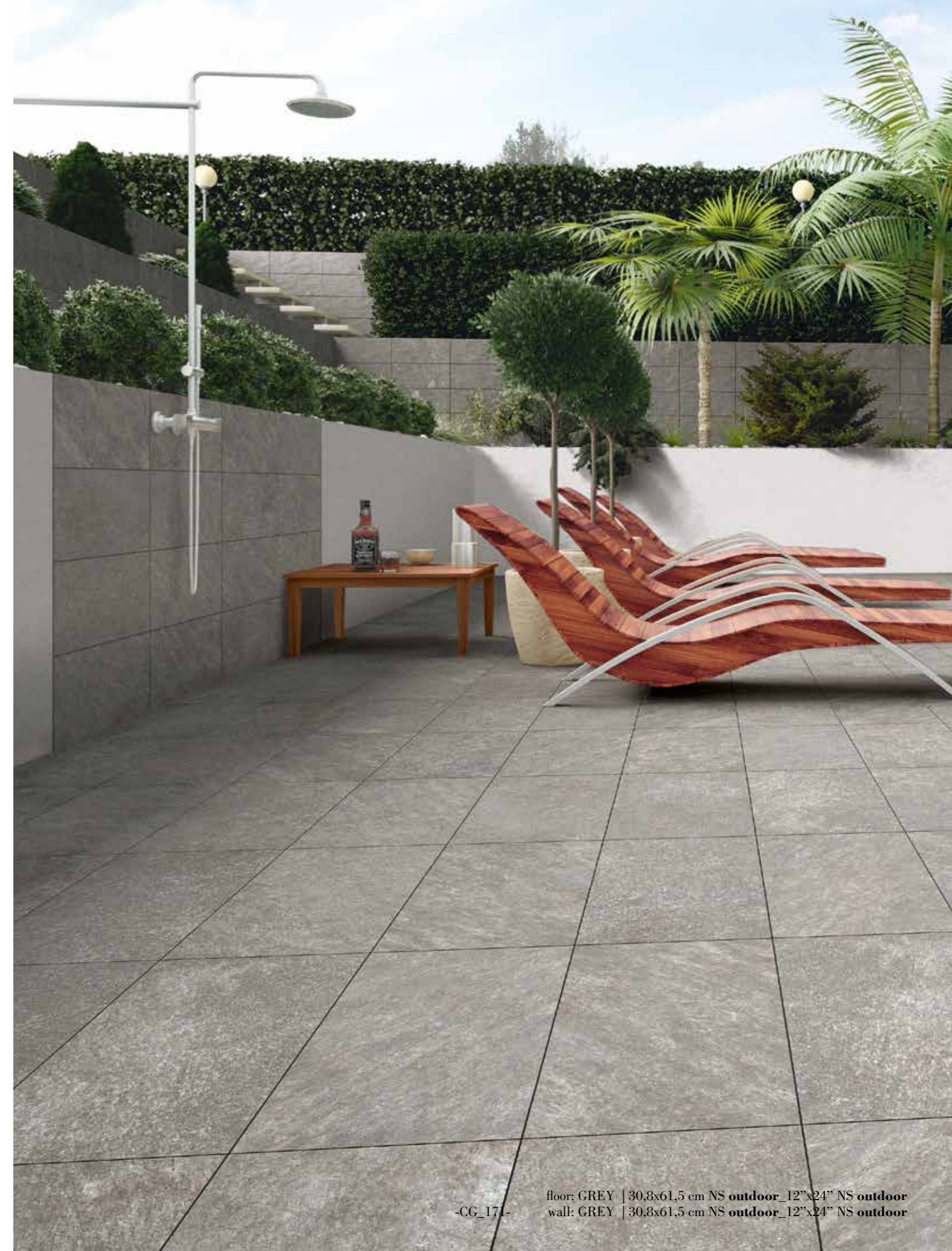

# EDELWEISS

Impasto Colorato  
Colored Body  
Masse Colorée  
Durchgefärbt



**RS** Rettificato/Strutturato -  
Rectified/Textured

**NS** Naturale/Strutturato -  
Natural/Textured

FP-2  
pag. 358

**FP2**  
**NS RS**

**NS**

\*61,5x61,5 cm NS .  
24"x24" NS  
\*61,0x61,0 cm RS .  
24"x24" RS  
\*coal, grey

30,8x61,5 cm NS - outdoor .  
12"x24" NS - outdoor

EDELWEISS  
Per la disponibilità articolo: [www.tuscaniagres.it](http://www.tuscaniagres.it)  
digitando il codice web segnalato a lato dei formati.  
For the item's availability: [www.tuscaniagres.it](http://www.tuscaniagres.it)  
type the web code reported next to the sizes.  
Pour vérifier la disponibilité de l'article: [www.tuscaniagres.it](http://www.tuscaniagres.it)  
en saisissant le code web indiqué à coté des formats.  
Für die Artikelverfügbarkeit: [www.tuscaniagres.it](http://www.tuscaniagres.it)  
web code eingeben, an der Seite von Formaten angedeutet.

GREY | 30,8x61,5 cm NS outdoor\_12"x24" NS outdoor



white



**L2U2** | 30,8x61,5 cm 12"x24" OUTDOOR **NS** **26,23**

beige



**I1P9** | 30,8x61,5 cm 12"x24" OUTDOOR **NS** **26,23**

grey



**I1P8** | 30,8x61,5 cm 12"x24" OUTDOOR **NS** **26,23**

coal



**I1P7** | 30,8x61,5 cm 12"x24" OUTDOOR **NS** **26,23**

FP-2

**I7O9** | 61,5x61,5 cm 24"x24" FP2 **NS** **55,56**

**I1U8** | 61,0x61,0 cm 24"x24" FP2 **RS** **67,90**

FP-2

**I7O8** | 61,5x61,5 cm 24"x24" FP2 **NS** **55,56**

**I1U9** | 61,0x61,0 cm 24"x24" FP2 **RS** **67,90**

pezzi speciali - special pieces - pièces spéciales - formteile



white



grey



coal



beige

elemento "L" monolitico outdoor

15x61x4 cm 6"x24"x1 3/4" **33,95/PZ**

white

grey

coal

beige



white



grey



coal

beige

battiscopa 12  
7,5x61,5 cm 3"x24"

**4,78/PZ**

white

grey

coal

beige

Note - Notes - Notes - Anmerkungen

I battiscopa vengono venduti a pz. e a scatola completa. Tutti gli altri pezzi speciali vengono venduti al pezzo. I gradini vengono prodotti solo su ordinazione (tempo minimo di consegna 20 gg lavorativi).  
Skirtings are sold by piece and full boxes. All other special trims are sold by piece. Steps are produced only on request (minimum delivery terms of 20 days).  
Les plinthes sont vendues la pièce et par boîte complète. Les autres pièces spéciales sont vendus la pièce. Le plat de marche sont produit sur demande (délai minimum de 20 jours).  
Die Sockelleisten werden pro Stk. und Vollen Kartons verkauft. Stufen und Stufenecken werden nur auf Bestellung produziert (Lieferzeiten mindesten 20 arbeitstagen ab Auftragserteilung).



# ETRURIA

---

*Grès porcellanato smaltato*  
*Glazed porcelain stoneware . Grès cérame émaillé . Glasiertes feinsteinzeug*

*effetto pietra*  
*stone-look*  
*effet pierre*  
*steinoptik*



*Un' alchimia produttiva esclusiva celebra lo splendore della pietra reinterpretandola nella sua particolare conformazione cromatica e granulometrica.*  
*Pura energia materica proposta in quattro colori base in grado di evocare suggestive ed imprevedibili atmosfere di vita.*

---

*An exclusive production alchemy that celebrates the splendour of stone by reinterpreting its special composition, colour and particle size.*  
*Pure textures proposed in four basic colours able to create captivating and surprising living atmospheres.*

*Une féconde et exclusive alchimie célèbre la splendeur de la pierre en la réinterprétant dans sa conformation chromatique et granulométrique particulière.*  
*Énergie de la matière à l'état pur, proposée en quatre couleurs base sachant évoquer des atmosphères de vie aussi suggestives qu'imprévisibles.*

*Eine exklusive produktive Alchemie zelebriert die Herrlichkeit des Steins und interpretiert ihn in seiner besonderen chromatischen Darstellung und der Körnung.*  
*Reine materische Energie, die in vier Basisfarben vorgeschlagen wird, die suggestive und unvorhersehbare Lebensatmosphären schaffen.*

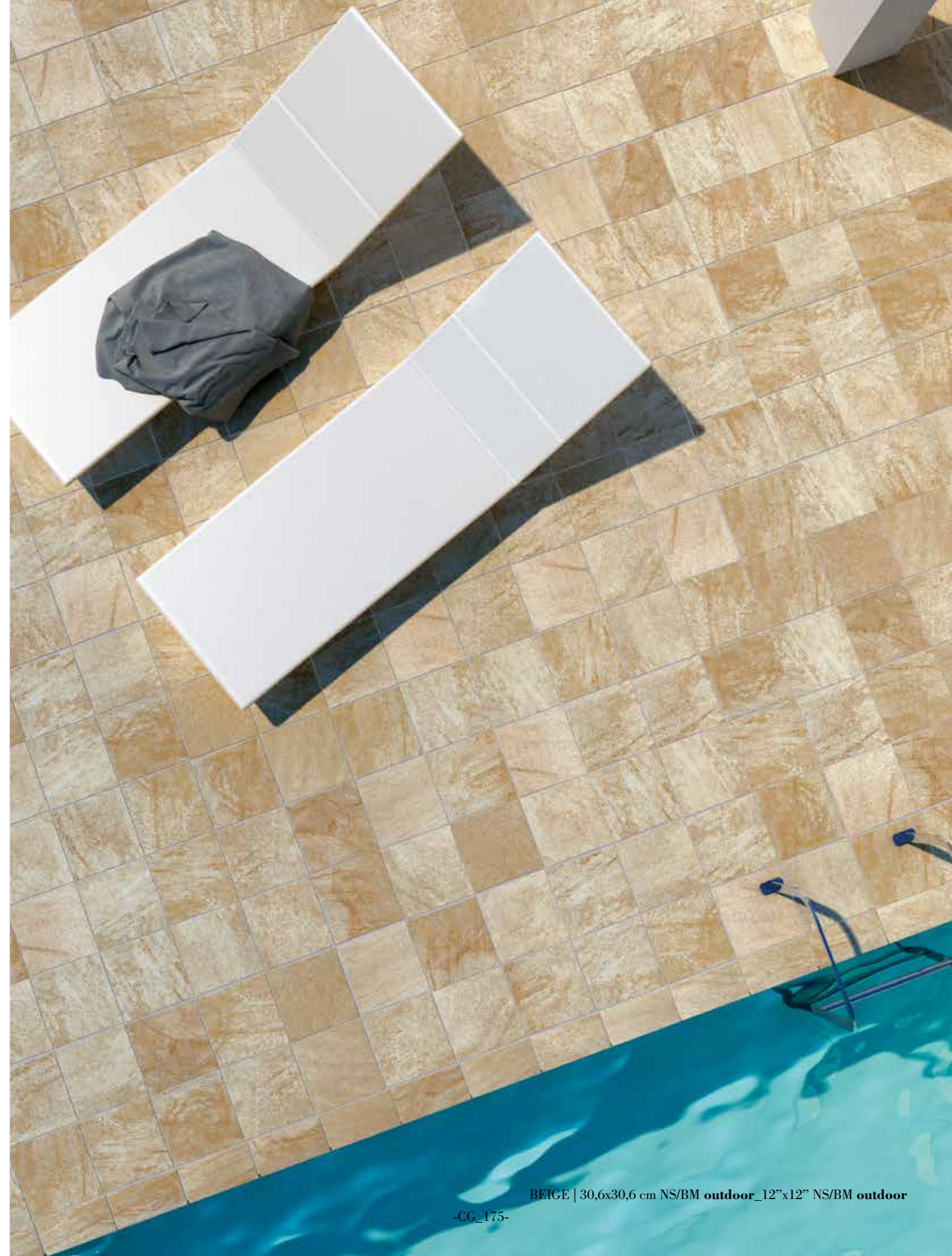



CENERE | 15,1x30,6 cm NS/BM outdoor\_6"x12" NS/BM outdoor

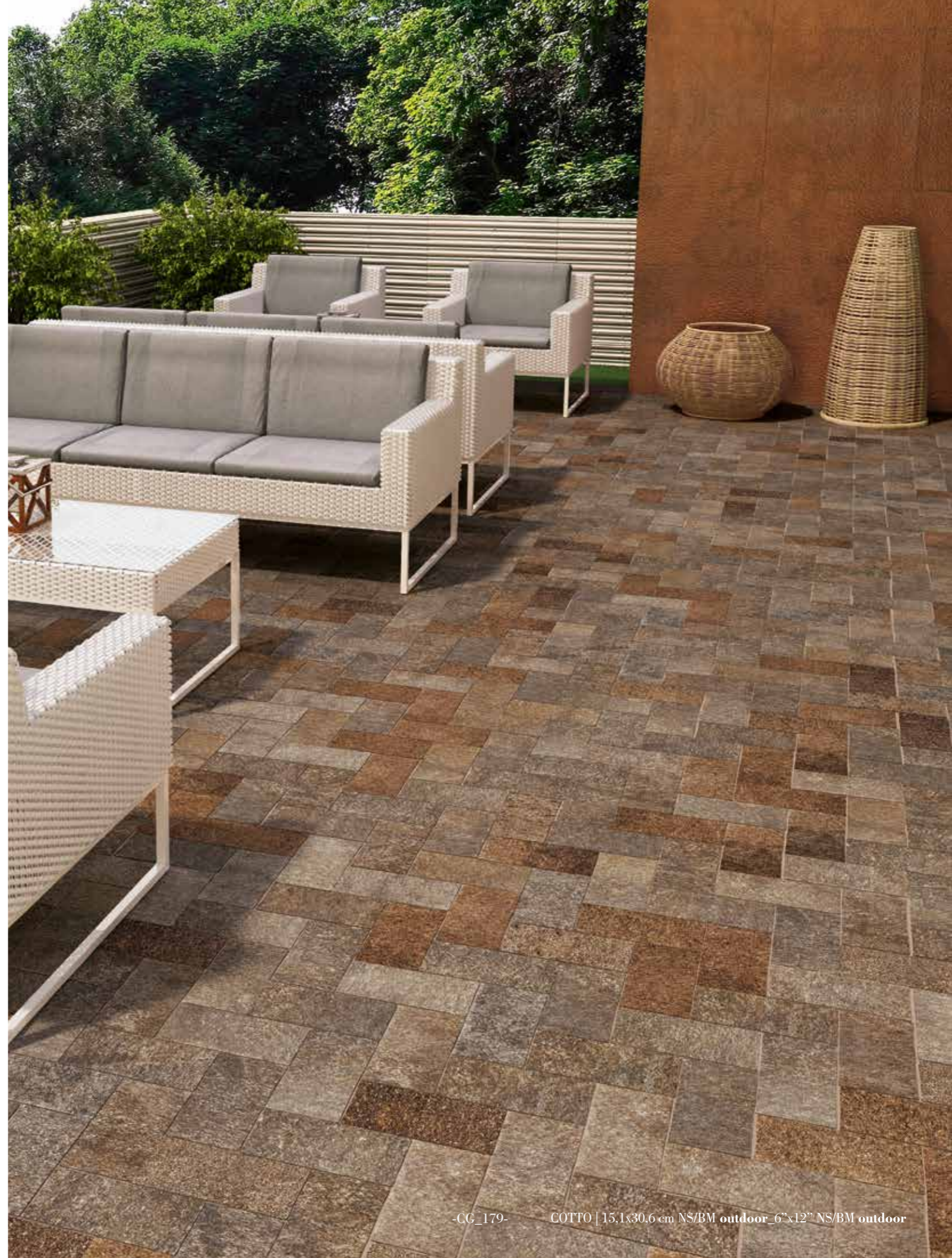
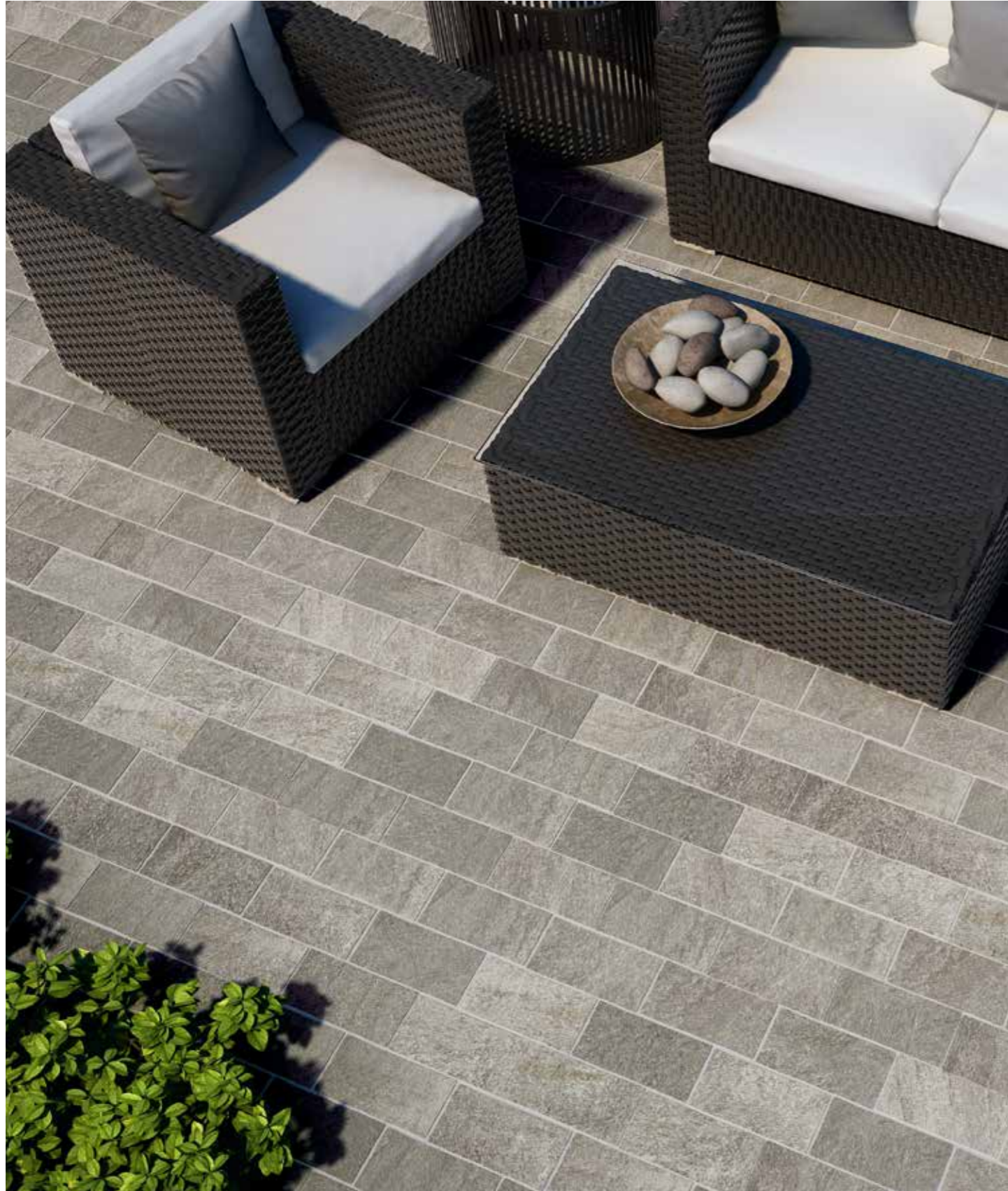

# ETRURIA

Grès porcellanato smaltato  
Glazed porcelain stoneware  
Grès cérame émaillé  
Glasiertes Feinsteinzeug



**NS/BD** 30,8x61,5  
Naturale strutturato/Bordo dritto  
Natural textured/Straight edges

**NS/BM** 30,6x30,6 e 15,1x30,6  
Naturale strutturato/Bordo mosso  
Natural textured/Slight edges



\*30,8x61,5 cm NS/BD outdoor.  
12"x24" NS/BD outdoor  
\*grigio, cenere, beige



30,6x30,6 cm NS/BM outdoor.  
12"x12" NS/BM outdoor



15,1x30,6 cm NS/BM outdoor.  
6"x12" NS/BM outdoor

Il formato 30,8x61,5 non è modulare con i formati 30,6x30,6 e 15,1x30,6.  
Combined laying is not possible because size 30,8x61,5 can not be modular with 30,6x30,6 and 15,1x30,6.  
Le format 30,8x61,5 n'est pas modulable aux formats 30,6x30,6 et 15,1x30,6.  
Das Format 30,8x61,5 ist nicht modular mit die Formate 30,6x30,6 und 15,1x30,6.

Materiale non esattamente calibrato; prevedere fuga di 5 mm.  
Calibration of this product is not exact; please consider a 5 mm joint.  
Matériel non calibré de manière précise; prévoir un joint de 5 mm.  
Nicht exakt rektifiziertes Material, es muss eine Fuge von 5 mm vorgesehen werden.

Per la disponibilità articolo: [www.tuscaniagres.it](http://www.tuscaniagres.it)  
digitando il codice web segnalato a lato dei formati.  
For the item's availability: [www.tuscaniagres.it](http://www.tuscaniagres.it)  
type the web code reported next to the sizes.  
Pour vérifier la disponibilité de l'article: [www.tuscaniagres.it](http://www.tuscaniagres.it)  
en saisissant le code web indiqué à côté des formats.  
Für die Artikelverfügbarkeit: [www.tuscaniagres.it](http://www.tuscaniagres.it)  
web code eingeben, an der Seite von Formaten angedeutet.

esempio di posa . laying compositions . exemple de pose . verlegemuster

30,6x30,6 cm NS/BM . 12"x12" NS/BM outdoor  
15,1x30,6 cm NS/BM . 6"x12" NS/BM outdoor



grigio

30,6x30,6 cm NS/BM . 12"x12" NS/BM outdoor



beige

15,1x30,6 cm NS/BM . 6"x12" NS/BM outdoor



cenere

15,1x30,6 cm NS/BM . 6"x12" NS/BM outdoor



cotto

grigio



L4U4	30,8x61,5 cm 12"x24" OUTDOOR	NS/BD	24,69
J4H2	30,6x30,6 cm 12"x12" OUTDOOR	NS/BM	23,15
J4M6	15,1x30,6 cm 6"x12" OUTDOOR	NS/BM	24,07

beige



L4U5	30,8x61,5 cm 12"x24" OUTDOOR	NS/BD	24,69
J4H0	30,6x30,6 cm 12"x12" OUTDOOR	NS/BM	23,15
J6M7	15,1x30,6 cm 6"x12" OUTDOOR	NS/BM	24,07

cenere



L4U6	30,8x61,5 cm 12"x24" OUTDOOR	NS/BD	24,69
J4H3	30,6x30,6 cm 12"x12" OUTDOOR	NS/BM	23,15
J8M6	15,1x30,6 cm 6"x12" OUTDOOR	NS/BM	24,07

cotto



J4H1	30,6x30,6 cm 12"x12" OUTDOOR	NS/BM	24,69
J8M7	15,1x30,6 cm 6"x12" OUTDOOR	NS/BM	24,07



battiscopa	7,5x30,6 cm 3"x12"	2,31/PZ
grigio		
cenere		
beige		
cotto		

pezzi speciali - special pieces - pièces spéciales - formteile



elemento "L" monolitico outdoor	15x30x4 cm 6"x12"x1 3/4"	10,80/PZ
grigio		
cenere		
beige		
cotto		

Note - Notes - Notes - Anmerkungen  
I battiscopa vengono venduti a pz. e a scatola completa. Tutti gli altri pezzi speciali vengono venduti al pezzo. I gradini vengono prodotti solo su ordinazione (tempo minimo di consegna 20 gg lavorativi).  
Skirtings are sold by piece and full boxes. All other special trims are sold by piece. Steps are produced only on request (minimum delivery terms of 20 days).  
Les plinthes sont vendues la pièce et par boîte complète. Les autres pièces spéciales sont vendus la pièce. Le plat de marche sont produit sur demande (délai minimum de 20 jours).  
Die Sockelleisten werden pro Stk. und Vollen Kartons verkauft. Stufen und Stufenecken werden nur auf Bestellung produziert (Lieferzeiten mindesten 20 arbeitstagen ab Auftragserteilung).

# TERRAFORTE

---

*Grès porcellanato smaltato*  
*Glazed porcelain stoneware . Grès cérame émaillé . Glasiertes feinsteinzeug*

*effetto pietra*  
*stone-look*  
*effet pierre*  
*steinoptik*



*L'elegante alternanza delle variazioni cromatiche legata alla tenace solidità delle pietra ed alla sua forte potenzialità espressiva genera una varietà di atmosfere calde e suggestive. Spazi attuali e senza tempo che solo le superfici autenticamente naturali sanno evocare.*

---

*The elegant alternation of colour variations combined with the solid tenacity of stone and its strong expressive power produces a variety of warm and captivating atmospheres. Contemporary and timeless spaces that only authentically natural surfaces can evoke.*

*L'élégante alternance des variations chromatiques liées à l'inébranlable solidité de la pierre et à son immense potentiel d'expression génère une variété d'atmosphères chaleureuses et évocatrices. Des espaces actuels et intemporels que seules les surfaces authentiquement naturelles savent faire revivre.*

*Die elegante Abwechslung der chromatischen Variationen verbunden mit der intensiven Solidität des Steins und der starken ausgedrückten Potentialität bildet eine abwechselnde warme und suggestive Atmosphäre. Aktuelle und zeitlose Räume, die nur echte natürliche Oberflächen hervorrufen können.*





# TERRAFORTE

Grès porcellanato smaltato  
Glazed porcelain stoneware  
Grès cérame émaillé  
Glasiertes Feinsteinzeug



**NS/BD** Naturale strutturato/Bordo dritto  
Natural textured/Straight edges

**RS/BD** Rettificato strutturato/Bordo dritto  
Rectified textured/Straight edges

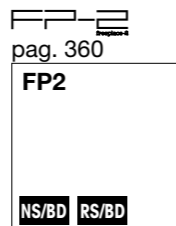

\*90x90 cm NS/BD .  
36"x36" NS/BD  
\*90x90 cm RS/BD .  
36"x36" RS/BD  
\*cenere

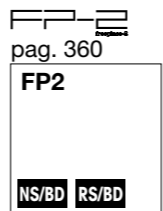

\*61,5x61,5 cm NS/BD . 24"x24" NS/BD  
\*61,0x61,0 cm RS/BD . 24"x24" RS/BD  
\*cenere

Il formato 30,8x61,5 non è modulare con il formato 15,1x30,6.  
Combined laying is not possible because size 30,8x61,5  
can not be modular with 15,1x30,6.  
Le format 30,8x61,5 n'est pas modulable aux format 15,1x30,6.  
Das Format 30,8x61,5 ist nicht modular mit die Formate 15,1x30,6.



\*30,8x61,5 cm NS/BD outdoor.  
12"x24" NS/BD outdoor  
\*bianco, dorato, grigio



15,1x30,6 cm NS/BD outdoor.  
6"x12" NS/BD outdoor

## TERRAFORTE

Per la disponibilità articolo: [www.tuscaniagres.it](http://www.tuscaniagres.it)  
digitando il codice web segnalato a lato dei formati.  
For the item's availability: [www.tuscaniagres.it](http://www.tuscaniagres.it)  
type the web code reported next to the sizes.  
Pour vérifier la disponibilité de l'article: [www.tuscaniagres.it](http://www.tuscaniagres.it)  
en saisissant le code web indiqué à coté des formats.  
Für die Artikelverfügbarkeit: [www.tuscaniagres.it](http://www.tuscaniagres.it)  
web code eingeben, an der Seite von Formaten angedeutet.

## bianco



**J3S5** | 30,8x61,5 cm 12"x24" OUTDOOR | **NS/BD** | 24,69  
**J2O3** | 15,1x30,6 cm 6"x12" OUTDOOR | **NS/BD** | 24,07

## grigio



**I7I8** | 30,8x61,5 cm 12"x24" OUTDOOR | **NS/BD** | 24,69  
**I1F3** | 15,1x30,6 cm 6"x12" OUTDOOR | **NS/BD** | 24,07

## dorato



**I7I9** | 30,8x61,5 cm 12"x24" OUTDOOR | **NS/BD** | 24,69  
**I1F4** | 15,1x30,6 cm 6"x12" OUTDOOR | **NS/BD** | 24,07

## cuoio



**I1F5** | 15,1x30,6 cm 6"x12" OUTDOOR | **NS/BD** | 24,07

## cenere



**J2O2** | 15,1x30,6 cm 6"x12" OUTDOOR | **NS/BD** | 24,07

**L4U7** | 90x90 cm 36"x36" FP2 | **NS/BD** | 61,73  
**L4U8** | 90x90 cm 36"x36" FP2 | **RS/BD** | 74,08  
**J9R3** | 61,5x61,5 cm 24"x24" FP2 | **NS/BD** | 55,56  
**J2Q9** | 61,0x61,0 cm 24"x24" FP2 | **RS/BD** | 67,90

## ruggine



**I1F6** | 15,1x30,6 cm 6"x12" OUTDOOR | **NS/BD** | 24,07

## tortora



**J4O0** | 15,1x30,6 cm 6"x12" OUTDOOR | **NS/BD** | 24,07



**battiscopa** 7,5x30,6 cm 3"x12" | **2,31/PZ**  
bianco  
cenere  
tortora  
grigio  
dorato  
cuoio  
ruggine



**elemento "L" monolitico outdoor**  
15x30x4 cm 6"x12"x1 3/4" | **10,80/PZ**  
bianco  
cenere  
tortora  
grigio  
dorato  
cuoio  
ruggine

pezzi speciali - special pieces - pièces spéciales - formteile



Note - Notes - Notes - Anmerkungen

I battiscopa vengono venduti a pz. e a scatola completa. Tutti gli altri pezzi speciali vengono venduti al pezzo. I gradini vengono prodotti solo su ordinazione (tempo minimo di consegna 20 gg lavorativi).  
Skirtings are sold by piece and full boxes. All other special trims are sold by piece. Steps are produced only on request (minimum delivery terms of 20 days).  
Les plinthes sont vendues la pièce et par boîte complète. Les autres pièces spéciales sont vendues la pièce. Le plat de marche sont produit sur demande (délai minimum de 20 jours).  
Die Sockelleisten werden pro Stk. und Vollen Kartons verkauft. Stufen und Stufenecken werden nur auf Bestellung produziert (Lieferzeiten mindesten 20 arbeitstagen ab Auftragserteilung).

# SPARKLY

*Grès porcellanato impasto colorato*  
*Color body porcelain stoneware . Grès cérame coloré dans la masse . Durchgefärbtes feinsteinzeug*

*effetto pietra*  
*stone-look*  
*effet pierre*  
*steinoptik*

RUGGINE

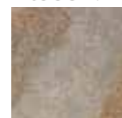

*Un materiale dai tratti decisamente rustici,  
ma con un atteggiamento originale e moderno.*  
*Attraverso le venature striate color ruggine, mette in evidenza  
i segni del tempo e l'effetto superficiale della pietra grezza  
rivisitata secondo una nuova interpretazione materica.*

*A distinctly rustic material,  
that still has an original and modern attitude.*  
*The rust-coloured vein markings enhance  
the signs of time and the superficial effect of natural stone  
in a totally new interpretation.*

*Un matériau aux traits résolument rustiques,  
mais avec une approche originale et moderne.*  
*A travers les veinures striées couleur rouille,  
il met en évidence les signes du temps et  
l'effet de surface de la pierre brute  
revisitée selon une nouvelle interprétation matérielle.*

*Ein Material mit ausgesprochen rustikalen Eigenschaften,  
aber mit einem originellen und modernen Flair.*  
*Durch die rostfarbenen gestreiften Adern hebt er die Zeichen der  
Zeit und die Oberflächenwirkung des Rohsteins hervor,  
der nach einer neuen Materialinterpretation neu interpretiert wurde.*





# SPARKLY

Impasto Colorato  
Colored Body  
Masse Colorée  
Durchgefärbt



**NS** Naturale/Strutturato - Natural/Textured  
**RS** Rettificato/Strutturato - Rectified/Textured

FP2  
pag. 362

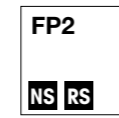

61,5x61,5 cm NS .  
24"x24" NS  
61,0x61,0 cm RS .  
24"x24" RS



30,8x61,5 cm NS outdoor.  
12"x24" NS outdoor

## ruggine\*



H3Q2 | 30,8x61,5 cm 12"x24" OUTDOOR **NS** 26,23



H3U2 | 61,5x61,5 cm 24"x24" FP2 **NS** 55,56

H3U5 | 61,0x61,0 cm 24"x24" FP2 **RS** 67,90

\*Abbinabile a - match with:  
15,1x30,6 cm NS/BD -  
6"x12" NS/BD OUTDOOR  
Terraforte Ruggine (pag. 182)

pezzi speciali - special pieces - pièces spéciales - formteile



ruggine battiscopa   
6,5x61,5 cm 2 1/2"x24"  
ruggine

4,78/PZ

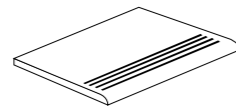

step  
30,8x61,5 cm 12"x24"  
ruggine

15,45/PZ

Note - Notes - Notes - Anmerkungen

I battiscopa vengono venduti a pz. e a scatola completa. Tutti gli altri pezzi speciali vengono venduti al pezzo. I gradini vengono prodotti solo su ordinazione (tempo minimo di consegna 20 gg lavorativi).  
Skirtings are sold by piece and full boxes. All other special trims are sold by piece. Steps are produced only on request (minimum delivery terms of 20 days).  
Les plinthes sont vendues la pièce et par boîte complète. Les autres pièces spéciales sont vendus la pièce. Le plat de marche sont produit sur demande (délai minimum de 20 jours).  
Die Sockelleisten werden pro Stk. und Vollen Kartons verkauft. Stufen und Stufenecken werden nur auf Bestellung produziert (Lieferzeiten mindesten 20 arbeitstagen ab Auftragserteilung).

## SPARKLY

Per la disponibilità articolo: [www.tuscaniagres.it](http://www.tuscaniagres.it)  
digitando il codice web segnalato a lato dei formati.  
For the item's availability: [www.tuscaniagres.it](http://www.tuscaniagres.it)  
type the web code reported next to the sizes.  
Pour vérifier la disponibilité de l'article: [www.tuscaniagres.it](http://www.tuscaniagres.it)  
en saisissant le code web indiqué à coté des formats.  
Für die Artikelverfügbarkeit: [www.tuscaniagres.it](http://www.tuscaniagres.it)  
web code eingeben, an der Seite von Formaten angedeutet.

RUGGINE FP2 | 61,5x61,5 cm NS\_24"x24" NS

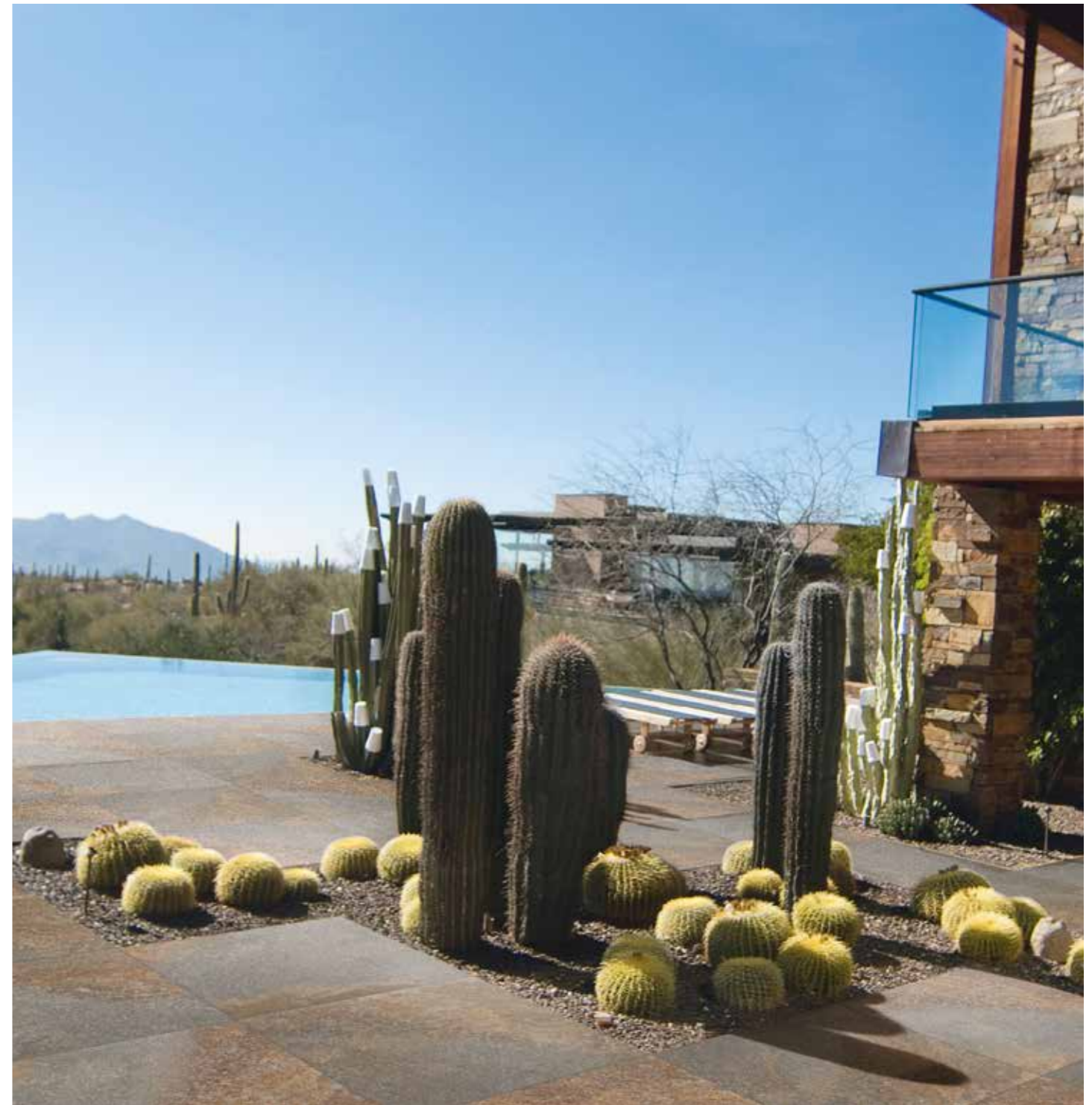

# QUARZO

---

*Grès porcellanato smaltato*  
*Glazed porcelain stoneware . Grès cérame émaillé . Glasiertes feinsteinzeug*

*effetto pietra*  
*stone-look*  
*effet pierre*  
*steinoptik*

GRIGIO    BEIGE



*Reinterpretare il quarzo significa credere nelle sue numerose applicazioni architettoniche nell' intero arco della storia dell' uomo. Applicazioni che non hanno paragoni a livello ornamentale e qualitativo, elevando questo prodotto a materia prima d'eccellenza.*

*To re-interpret quartz, it is necessary to believe in its countless applications in architecture throughout the story of mankind. The decorative appeal and quality of these applications are unrivalled, making this material truly outstanding.*

*Réinterpréter le quartz signifie croire en ses nombreuses applications architecturales tout au long de l'histoire de l'homme. Applications qui n'ont pas d'équivalent sur le plan décoratif et qualitatif, élevant ce produit au niveau d'une matière première d'excellence.*

*Diese Neuinterpretation von Quarz bedeutet, an die zahlreichen architektonischen Anwendungen in der Geschichte der Menschheit zu glauben. Anwendungen, die in Bezug auf Ornamentalität und Qualität unerreicht sind und dieses Produkt zu einem hervorragenden Rohstoff machen.*

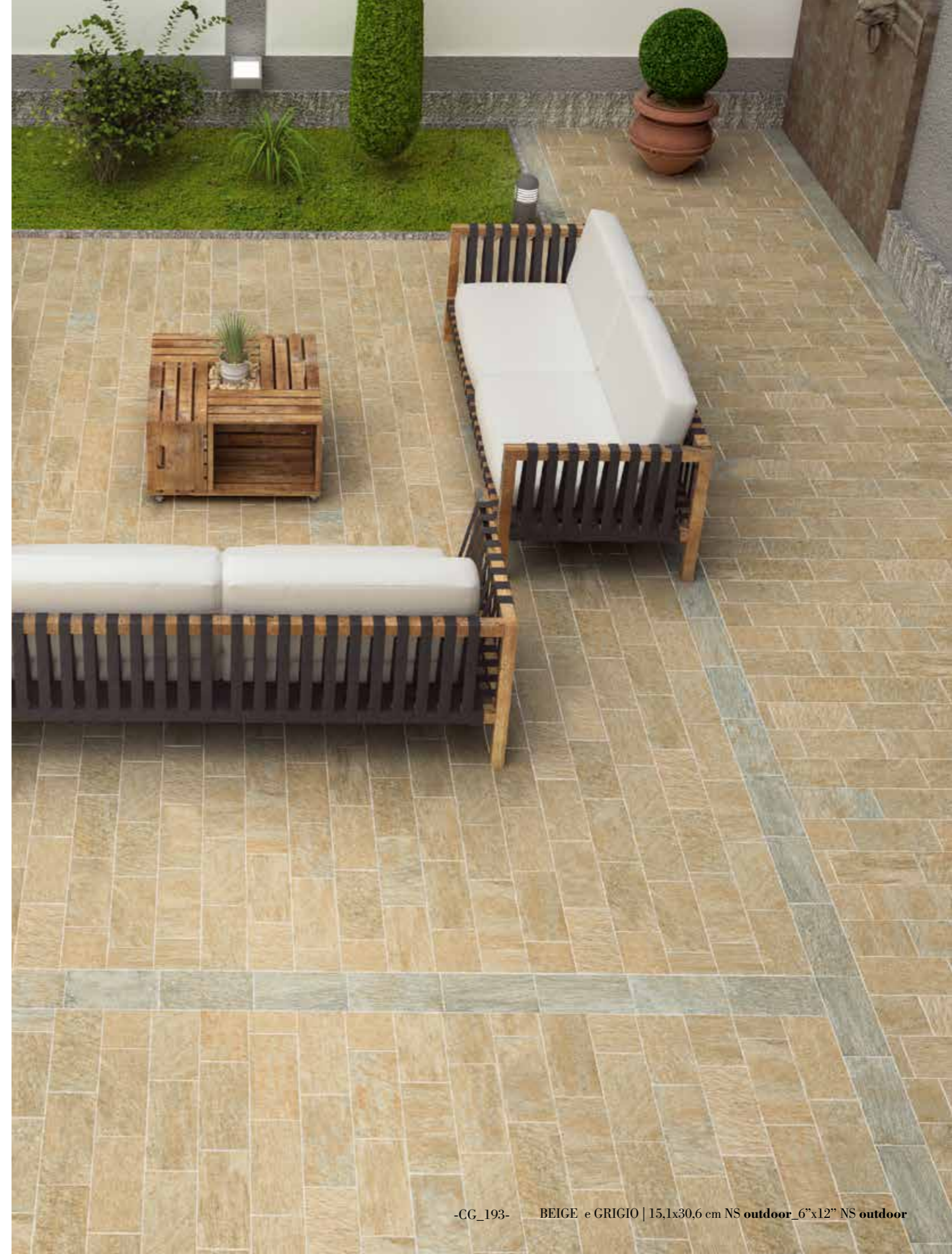

# QUARZO

Grès porcellanato smaltato  
Glazed porcelain stoneware  
Grès cérame émaillé  
Glasiertes Feinsteinzeug



**NS/BD** Naturale strutturato/Bordo dritto  
Natural textured/Straight edges



15,1x30,6 cm NS outdoor.  
6"x12" NS outdoor

grigio



**L6K9** | 15,1x30,6 cm 6"x12" OUTDOOR **NS/BD** **24,07**

beige



**L3J8** | 15,1x30,6 cm 6"x12" OUTDOOR **NS/BD** **24,07**

esempio di posa . laying compositions . exemple de pose . verlegemuster

grigio

15,1x30,6 cm NS/BD outdoor\_6"x12" NS/BD outdoor



beige

15,1x30,6 cm NS/BD outdoor\_6"x12" NS/BD outdoor



# QUARZO

Per la disponibilità articolo: [www.tuscaniagres.it](http://www.tuscaniagres.it)  
digitando il codice web segnalato a lato dei formati.  
For the item's availability: [www.tuscaniagres.it](http://www.tuscaniagres.it)  
type the web code reported next to the sizes.  
Pour vérifier la disponibilité de l'article: [www.tuscaniagres.it](http://www.tuscaniagres.it)  
en saisissant le code web indiqué à côté des formats.  
Für die Artikelverfügbarkeit: [www.tuscaniagres.it](http://www.tuscaniagres.it)  
web code eingeben, an der Seite von Formaten angedeutet.

GRIGIO | 15,1x30,6 cm NS/BD outdoor\_6"x12" NS/BD outdoor



pezzi speciali - special pieces - pièces spéciales - formteile



grigio

battiscopa **136**  
7,5x30,6 cm 3"x12"

grigio

beige



beige

**2,31/PZ**



grigio

elemento "L" monolitico outdoor  
15x30x4 cm 6"x12"x1 3/4"

grigio

beige

beige

**10,80/PZ**

Note - Notes - Notes - Anmerkungen

I battiscopa vengono venduti a pz. e a scatola completa. Tutti gli altri pezzi speciali vengono venduti al pezzo. I gradini vengono prodotti solo su ordinazione (tempo minimo di consegna 20 gg lavorativi).  
Skirtings are sold by piece and full boxes. All other special trims are sold by piece. Steps are produced only on request (minimum delivery terms of 20 days).  
Les plinthes sont vendues la pièce et par boîte complète. Les autres pièces spéciales sont vendus la pièce. Le plat de marche sont produit sur demande (délai minimum de 20 jours).  
Die Sockelleisten werden pro Stk. und Vollen Kartons verkauft. Stufen und Stufenecken werden nur auf Bestellung produziert (Lieferzeiten mindesten 20 arbeitstagen ab Auftragserteilung).

# BRICKS

---

*Grès porcellanato impasto colorato*  
*Color body porcelain stoneware . Grès cérame coloré dans la masse . Durchgefärbtes Feinsteinzeug*

*effetto pietra*  
*stone-look*  
*effet pierre*  
*steinoptik*



*Un prodotto di nicchia esclusivo e qualificato  
per un mercato dinamico ed esigente.*  
*“Bricks” interpreta la ceramica definendo superfici inedite e  
fantasiose ispirate all'eleganza ed  
alla policromia tridimensionale dei muretti contemporanei.*

*An exclusive and qualified niche product for  
a dynamic and demanding market.*  
*“Bricks” interprets ceramic by creating brand-new surfaces and  
patterns inspired by elegance and the three-dimensional  
polychrome aspect of contemporary walls.*

*Un produit de niche exclusif et efficace pour  
un marché dynamique et exigeant.*  
*“Bricks” interprète la céramique en définissant des surfaces inédites  
et pleines de fantaisie, inspirées de l'élégance et de la polychromie  
tridimensionnelles des baguette “muret” contemporaines.*

*Ein exklusives und qualifiziertes Nischenprodukt  
für einen dynamischen und anspruchsvollen Markt.*  
*“Bricks” interpretiert die Keramik und definiert nie gesehene  
und phantasievolle Oberflächen, die sich an der Eleganz und der  
dreidimensionalen Polychromie der kontemporären Mauern inspirieren.*



# BRICKS

Impasto Colorato  
Colored Body  
Masse Colorée  
Durchgefärbt



**R** Rettificato -  
Rectified



37,5x75 cm R . 15"x30" R

white



J9Q7 | 37,5x75 cm 15"x30" **R** 32,41

grey



J9Q8 | 37,5x75 cm 15"x30" **R** 32,41

classic



J9Q9 | 37,5x75 cm 15"x30" **R** 32,41

wall: CLASSIC | 37,5x75 cm R\_15"x30" R  
floor: SHINE GREY | 61,3x122,6 cm R\_24"x48" R



-CG\_198-

# BRICKS

Per la disponibilità articolo: [www.tuscaniagres.it](http://www.tuscaniagres.it)  
digitando il codice web segnalato a lato dei formati.  
For the item's availability: [www.tuscaniagres.it](http://www.tuscaniagres.it)  
type the web code reported next to the sizes.  
Pour vérifier la disponibilité de l'article: [www.tuscaniagres.it](http://www.tuscaniagres.it)  
en saisissant le code web indiqué à coté des formats.  
Für die Artikelverfügbarkeit: [www.tuscaniagres.it](http://www.tuscaniagres.it)  
web code eingeben, an der Seite von Formaten angedeutet.

wall: CLASSIC | 37,5x75 cm R\_15"x30" R - floor: SHINE GREY | 61,3x122,6 cm R\_24"x48" R

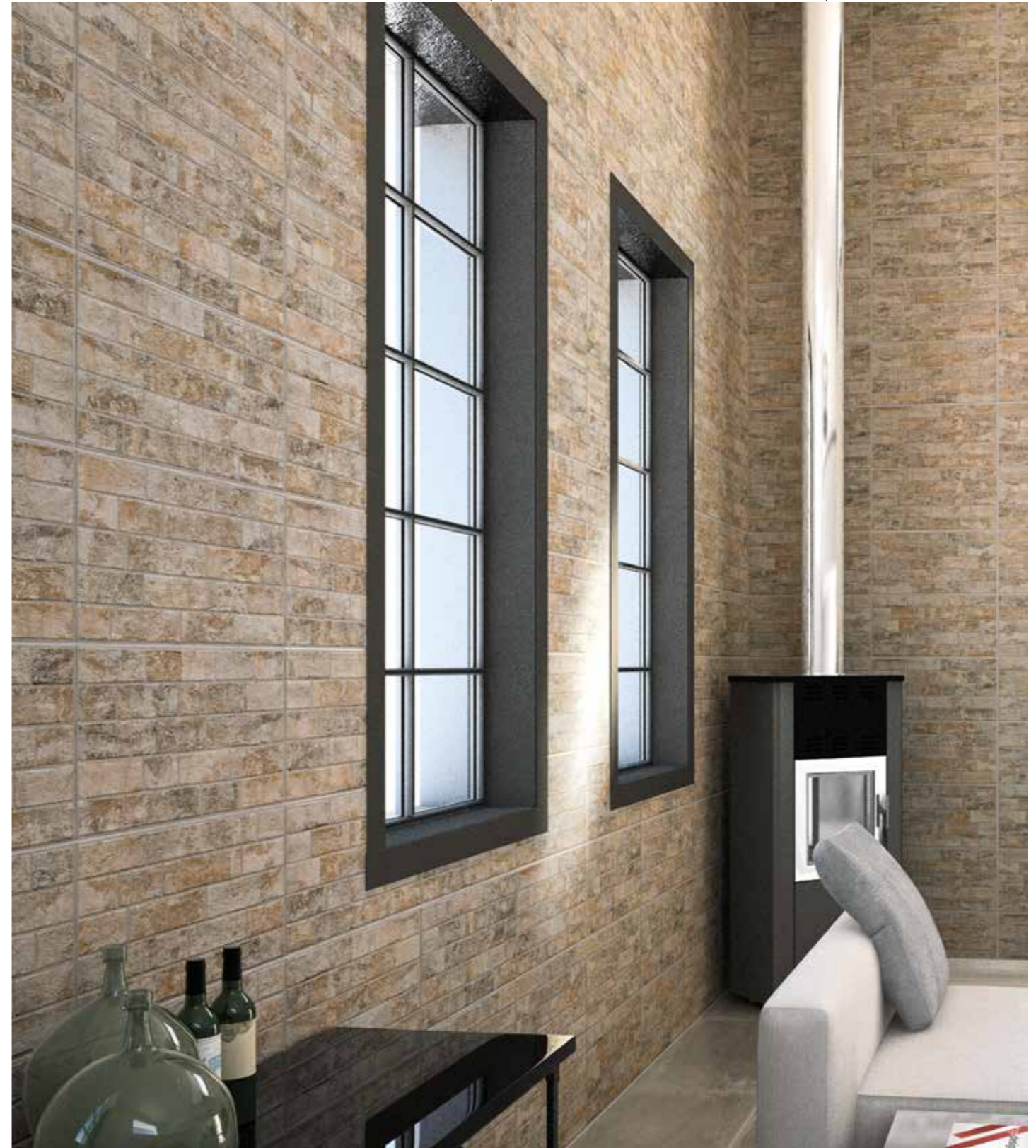

-CG\_199-

effetto marmo  
marble-look . effet marbre . marmoroptik



Athena	202
Piasentina	216
Stardust	210

*Grès porcellanato*  
*Porcelain stoneware*  
*Grès cérame coloré*  
*Feinsteinzeug*

# ATHENA

---

*Grès porcellanato impasto colorato*  
*Color body porcelain stoneware . Grès cérame coloré dans la masse . Durchgefärbtes Feinsteinzeug*

*effetto marmo*  
*marble-look*  
*effet marbre*  
*marmoroptik*

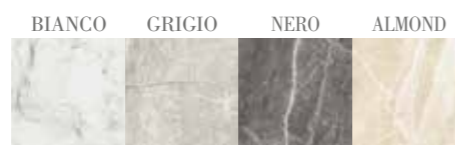

*Un' estetica raffinata generata  
da una trama marmorea naturale,  
ci porta a superfici di altissimo pregio.*  
*Un rigore ed una compostezza di ispirazione classica trova  
lo scenario ideale in ambienti che cercano la luce ed il colore.*

---

*A sophisticated appearance generated  
by a natural marble effect  
that evokes images of highly prized surfaces.  
The rigour and classic inspiration find their  
ideal setting in places that search for light and colour.*

*Une esthétique raffinée née  
d'une trame de marbre naturelle,  
nous conduit à des surfaces de très haute valeur.*  
*Une rigueur et un aplomb d'inspiration classique trouve  
le scénario idéal dans les espaces qui réclament lumière et couleur*

*Eine raffinierte Ästhetik, erzeugt durch eine natürliche Marmorstruktur  
lässt Oberflächen von höchster Qualität entstehen.*  
*Eine klassisch inspirierte Strenge und Gelassenheit findet ihren  
idealen Rahmen in Räumen, auf der Suche nach Licht und Farbe.*







# ATHENA

Impasto Colorato  
Colored Body  
Masse Colorée  
Durchgefärbt



**N** Naturale Natural  
**R** Rettificato Rectified  
**LR** Lappato e rettificato Honed and rectified

## ATHENA

Per la disponibilità articolo: [www.tuscaniagres.it](http://www.tuscaniagres.it)  
digitando il codice web segnalato a lato dei formati.  
For the item's availability: [www.tuscaniagres.it](http://www.tuscaniagres.it)  
type the web code reported next to the sizes.  
Pour vérifier la disponibilité de l'article: [www.tuscaniagres.it](http://www.tuscaniagres.it)  
en saisissant le code web indiqué à coté des formats.  
Für die Artikelverfügbarkeit: [www.tuscaniagres.it](http://www.tuscaniagres.it)  
web code eingeben, an der Seite von Formaten angedeutet.

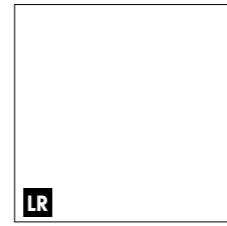

\*122,6x122,6 cm LR . 48"x48" LR  
\*grigio, nero, almond



60,0x121,0 cm LR . 24"x48" LR



61,5x61,5 cm N . 24"x24" N  
61,0x61,0 cm R . 24"x24" R  
61,0x61,0 cm LR . 24"x24" LR



30,8x61,5 cm N . 12"x24" N  
30,4x61,0 cm R . 12"x24" R  
30,2x60,8 cm LR . 12"x24" LR

## bianco



I6I6	61,5x61,5 cm 24"x24"	<b>N</b>	29,32
I7I0	61,0x61,0 cm 24"x24"	<b>R</b>	37,04
L9Q0	61,0x61,0 cm 24"x24"	<b>LR</b>	52,47
L0N7	60,0x121,0 cm 24"x48"	<b>LR</b>	64,82
I2I4	30,8x61,5 cm 12"x24"	<b>N</b>	24,69
I8I2	30,4x61,0 cm 12"x24"	<b>R</b>	33,95
L7Q8	30,2x60,8 cm 12"x24"	<b>LR</b>	49,39

## grigio



L952	122,6,0x122,6 cm 48"x48"	<b>LR</b>	80,25
I6I7	61,5x61,5 cm 24"x24"	<b>N</b>	29,32
I7I1	61,0x61,0 cm 24"x24"	<b>R</b>	37,04
L9Q1	61,0x61,0 cm 24"x24"	<b>LR</b>	52,47
L0N5	60,0x121,0 cm 24"x48"	<b>LR</b>	64,82
I2I5	30,8x61,5 cm 12"x24"	<b>N</b>	24,69
I8I3	30,4x61,0 cm 12"x24"	<b>R</b>	33,95
L7Q9	30,2x60,8 cm 12"x24"	<b>LR</b>	49,39

## nero



L953	122,6,0x122,6 cm 48"x48"	<b>LR</b>	80,25
I6I9	61,5x61,5 cm 24"x24"	<b>N</b>	29,32
I7I3	61,0x61,0 cm 24"x24"	<b>R</b>	37,04
L9Q2	61,0x61,0 cm 24"x24"	<b>LR</b>	52,47
L9M5	60,0x121,0 cm 24"x48"	<b>LR</b>	64,82
I8I1	30,8x61,5 cm 12"x24"	<b>N</b>	24,69
I8I5	30,4x61,0 cm 12"x24"	<b>R</b>	33,95
L7Q0	30,2x60,8 cm 12"x24"	<b>LR</b>	49,39

## almond



L954	122,6,0x122,6 cm 48"x48"	<b>LR</b>	80,25
I6I8	61,5x61,5 cm 24"x24"	<b>N</b>	29,32
I7I2	61,0x61,0 cm 24"x24"	<b>R</b>	37,04
L8Q9	61,0x61,0 cm 24"x24"	<b>LR</b>	52,47
L0N6	60,0x121,0 cm 24"x48"	<b>LR</b>	64,82
I8I0	30,8x61,5 cm 12"x24"	<b>N</b>	24,69
I8I4	30,4x61,0 cm 12"x24"	<b>R</b>	33,95
L7Q7	30,2x60,8 cm 12"x24"	<b>LR</b>	49,39

Avvertenze: i formati rettificati non sono modulari in nessun formato con i formati lappati.  
Note: the rectified formats cannot be combined with the lapped formats.  
Avertissement : les formats rectifiés ne sont modulaires en aucun format avec les formats polis.  
Hinweis: Gleichgerichtete Formate sind in keinem Format mit geläpften Formaten modular.

# ATHENA

ATHENA

decori - decors - décors - dekors

patchwork - 30x30 cm 12"x12"  20,37/PZ

bianco



grigio



nero

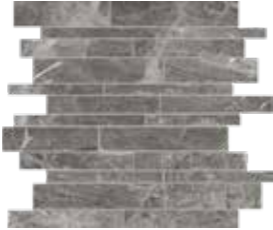

almond



mosaico monocolore 36 tessere 5x5 - 30x30 cm 12"x12"  13,27/PZ

bianco



grigio



nero

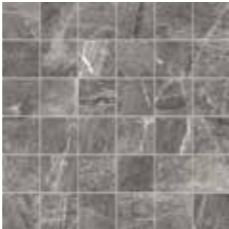

almond



mosaico monocolore mix N/L 81 tessere 3x3 - 30x30 cm 12"x12"  13,89/PZ

bianco



grigio



nero

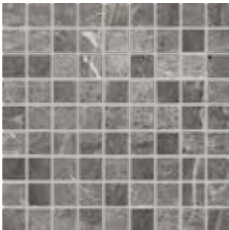

almond



ALMOND | 60,0x60,0 cm LR\_24"x24" LR



pezzi speciali - special pieces - pièces spéciales - fornteile

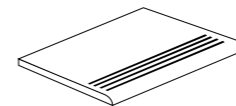

step  
30,8x61,5 cm 12"x24" **N** 15,45/PZ

almond  
bianco  
grigio  
nero



gradino costa retta  
34x61,5x4 cm 13"x24"x1<sup>3/4</sup>" **N** 83,33/PZ

almond  
bianco  
grigio  
nero

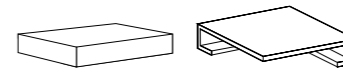

vista frontale vista dal retro  
angolare costa retta dx/sx  
34x34x4 cm 13"x13"x1<sup>3/4</sup>" **N** 103,40/PZ

almond  
bianco  
grigio  
nero



battiscopa   
6,5x61,5 cm N 2<sup>1/2</sup>"x24" N 4,78/PZ  
6,5x121,0 cm LR 2<sup>1/2</sup>"x48" LR 25,75/PZ

almond  
bianco  
grigio  
nero

Note - Notes - Notes - Anmerkungen  
I battiscopa vengono venduti a pz. e a scatola completa. Tutti gli altri pezzi speciali vengono venduti al pezzo. I gradini vengono prodotti solo su ordinazione (tempo minimo di consegna 20 gg lavorativi).  
Skirtings are sold by piece and full boxes. All other special trims are sold by piece. Steps are produced only on request (minimum delivery terms of 20 days).  
Les plinthes sont vendues la pièce et par boîte complète. Les autres pièces spéciales sont vendus la pièce. Le plat de marche sont produit sur demande (délai minimum de 20 jours).  
Die Sockelleisten werden pro Stk. und Vollen Kartons verkauft. Stufen und Stufenecken werden nur auf Bestellung produziert (Lieferzeiten mindesten 20 arbeitstagen ab Auftragserteilung).

# STARDUST

---

*Grès porcellanato impasto colorato*

*Color body porcelain stoneware . Grès cérame coloré dans la masse . Durchgefärbtes feinsteinzeug*

*effetto marmo  
marble-look  
effet marbre  
marmoroptik*



*Una gamma cromatica studiata su toni chiari e rilassanti interpreta un materiale storico attraverso un gusto contemporaneo. Quattro colori oniciati, lucidi e luminosi che, con l'apporto di mosaici, possono essere spezzati per vivacizzare le superfici con un gioco geometrico di incastri ed intarsi.*

*A colour range in carefully selected light, relaxing shades interprets a historic material with a contemporary feel. Four bright, luminous onyx-effect shades that can be used, together with mosaics, to brighten up any surface with a geometric pattern of interlocked pieces and inlays.*

*Une gamme chromatique étudiée sur des tons clairs et apaisants interprète un matériau historique par le prisme d'un goût contemporain. Quatre couleurs aspect onyx, brillantes et lumineuses qui, avec l'apport de mosaïques, peuvent être brisées pour raviver les surfaces avec un jeu géométrique d'entrelacements et d'emboîtements.*

*Eine in hellen und entspannenden Tönen gehaltene Farbpalette interpretiert ein historisches Material mit einer modernen Stilsprache. Vier glänzende und leuchtende Onyxfarben, die mit Hilfe von Mosaiken gebrochen werden können, um die Oberflächen mit einem geometrischen Spiel von Einschnitten und Intarsien zu beleben.*





indoor: GREY | 60,0x121,0 cm LR\_24"x48" LR  
outdoor: TECHNIKA GRIGIO FP2 | 61,0x61,0 cm RS\_24"x24" RS

# STARDUST

Impasto Colorato  
Colored Body  
Masse Colorée  
Durchgefärbt



**LR** Lappato e rettificato  
Honed and rectified



80,0x160,0 cm LR . 31"x62" LR

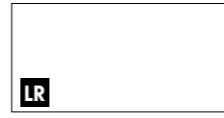

60,0x121,0 cm LR . 24"x48" LR

STARDUST  
Per la disponibilità articolo: [www.tuscaniagres.it](http://www.tuscaniagres.it)  
digitando il codice web segnalato a lato dei formati.  
For the item's availability: [www.tuscaniagres.it](http://www.tuscaniagres.it)  
type the web code reported next to the sizes.  
Pour vérifier la disponibilité de l'article: [www.tuscaniagres.it](http://www.tuscaniagres.it)  
en saisissant le code web indiqué à côté des formats.  
Für die Artikelverfügbarkeit: [www.tuscaniagres.it](http://www.tuscaniagres.it)  
web code eingeben, an der Seite von Formaten angedeutet.

decori - decors - décors - dekors

white



**L4U9** 80,0x160,0 cm 31"x62" **LR** 80,25  
**L7N8** 60,0x121,0 cm 24"x48" **LR** 64,82

almond



**L5U0** 80,0x160,0 cm 31"x62" **LR** 80,25  
**L7N5** 60,0x121,0 cm 24"x48" **LR** 64,82

grey



**L5U1** 80,0x160,0 cm 31"x62" **LR** 80,25  
**L7N6** 60,0x121,0 cm 24"x48" **LR** 64,82

walnut



**L5U2** 80,0x160,0 cm 31"x62" **LR** 80,25  
**L7N7** 60,0x121,0 cm 24"x48" **LR** 64,82

mosaico monocolore lappato 36 tessere 5x5 - 30x30 cm 12"x12" 24,70/PZ

white



grey



almond



walnut



mosaico monocolore lappato 81 tessere 3x3 - 30x30 cm 12"x12" 24,70/PZ

white

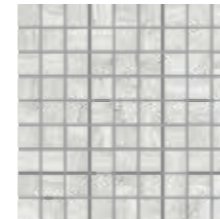

grey



almond



walnut

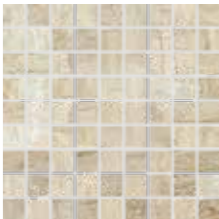

pezzi speciali - special pieces - pièces spéciales - formteile



white

grey

almond

walnut

**battiscopa** 101  
6,5x120,0 cm LR 2 1/2"x48" LR **LR** 25,75/PZ  
white  
grey  
almond  
walnut

Note - Notes - Notes - Anmerkungen

I battiscopa vengono venduti a pz. e a scatola completa. Tutti gli altri pezzi speciali vengono venduti al pezzo. I gradini vengono prodotti solo su ordinazione (tempo minimo di consegna 20 gg lavorativi).  
Skirtings are sold by piece and full boxes. All other special trims are sold by piece. Steps are produced only on request (minimum delivery terms of 20 days).  
Les plinthes sont vendues la pièce et par boîte complète. Les autres pièces spéciales sont vendus la pièce. Le plat de marche sont produit sur demande (délai minimum de 20 jours).  
Die Sockelleisten werden pro Stk. und Vollen Kartons verkauft. Stufen und Stufenecken werden nur auf Bestellung produziert (Lieferzeiten mindesten 20 arbeitstagen ab Auftragserteilung).

# PIASENTINA

*Grès porcellanato impasto colorato*

*Color body porcelain stoneware . Grès cérame coloré dans la masse . Durchgefärbtes feinsteinzeug*

*effetto marmo  
marble-look  
effet marbre  
marmoroptik*



*Una pietra di grande pregio e tradizione ricostruita seguendo una particolare ed esclusiva tecnologia produttiva derivata da una ricerca che ha voluto regalare soluzioni estetiche eleganti, attuali e moderne legate però da una tradizione autentica.*

*A highly precious, traditional stone reconstructed using a special, exclusive production technology derived from research aiming to create elegant, current and modern design solutions linked to authentic tradition.*

*Une pierre traditionnelle de grande valeur reconstruite en suivant une technologie de production particulière et exclusive issue d'une recherche qui a voulu offrir des solutions esthétiques élégantes, actuelles et modernes, liées toutefois par une tradition authentique.*

*Ein kostbarer und traditionsreicher Naturstein, der hier mithilfe einer besonderen und exklusiven Produktionstechnologie nachgeahmt wurde, die durch eine Forschungs- und Entwicklungsarbeit möglich wurde, deren Ziel elegante, aktuelle ästhetische Lösungen waren, die auf eine authentische Tradition aufbauen.*



# PIASENTINA

Impasto Colorato  
Colored Body  
Masse Colorée  
Durchgefärbt



30,8x61,5 cm N 45x90 cm LR 30,8x61,5 cm N  
12"x24" N 18"x36" LR 12"x24" N  
30,2x60,8 cm LR  
12"x24" LR

**N** Naturale Natural **LR** Lappato e rettificato Honed and rectified



45x90 cm LR . 18"x36" LR



30,8x61,5 cm N . 12"x24" N  
30,2x60,8 cm LR . 12"x24" LR

PIASENTINA  
Per la disponibilità articolo: [www.tuscaniagres.it](http://www.tuscaniagres.it)  
digitando il codice web segnalato a lato dei formati.  
For the item's availability: [www.tuscaniagres.it](http://www.tuscaniagres.it)  
type the web code reported next to the sizes.  
Pour vérifier la disponibilité de l'article: [www.tuscaniagres.it](http://www.tuscaniagres.it)  
en saisissant le code web indiqué à côté des formats.  
Für die Artikelverfügbarkeit: [www.tuscaniagres.it](http://www.tuscaniagres.it)  
web code eingeben, an der Seite von Formaten angedeutet.

MARFIL | 30,8x61,5 cm N\_12"x24" N

white



I9L0	45x90 cm 18"x36"	LR	64,81
I8L2	30,8x61,5 cm 12"x24"	N	24,69
I8L6	30,2x60,8 cm 12"x24"	LR	49,39

light grey



I9L1	45x90 cm 18"x36"	LR	64,81
I8L3	30,8x61,5 cm 12"x24"	N	24,69
I8L7	30,2x60,8 cm 12"x24"	LR	49,39



decori - decors - décors - dekors

dark grey



I9L2	45x90 cm 18"x36"	LR	64,81
I8L4	30,8x61,5 cm 12"x24"	N	24,69
I8L8	30,2x60,8 cm 12"x24"	LR	49,39

marfil



I9L3	45x90 cm 18"x36"	LR	64,81
I8L5	30,8x61,5 cm 12"x24"	N	24,69
I8L9	30,2x60,8 cm 12"x24"	LR	49,39

mosaico monocolore mix N/L 81 tessere 3x3 - 30x30 cm 12"x12" 13,89/PZ

white



light grey



dark grey

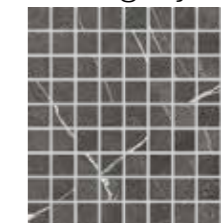

marfil



pezzi speciali - special pieces - pièces spéciales - formteile



battiscopa	6,5x61,5 cm N 2 <sup>1/2</sup> "x24" N	N	4,78/PZ
	6,5x60,8 cm LR 2 <sup>1/2</sup> "x24" LR	LR	12,97/PZ
white			
light grey			
dark grey			
marfil			

Note - Notes - Notes - Anmerkungen

I battiscopa vengono venduti a pz. e a scatola completa. Tutti gli altri pezzi speciali vengono venduti al pezzo. I gradini vengono prodotti solo su ordinazione (tempo minimo di consegna 20 gg lavorativi).  
Skirtings are sold by piece and full boxes. All other special trims are sold by piece. Steps are produced only on request (minimum delivery terms of 20 days).  
Les plinthes sont vendues la pièce et par boîte complète. Les autres pièces spéciales sont vendus la pièce. Le plat de marche sont produit sur demande (délai minimum de 20 jours).  
Die Sockelleisten werden pro Stk. und Vollen Kartons verkauft. Stufen und Stufenecken werden nur auf Bestellung produziert (Lieferzeiten mindesten 20 arbeitstagen ab Auftragserteilung).

effetto legno  
wood-look . effet bois . holzoptik



Bark	288
Chalet	284
Decapé floor	222
Dhoga	292
Fjord	246
Gushure	242
Kouros	280
Navajo	264
North Wind floor	254
Re-wood	230
Thunderwood	270
Unico	236
Woody Floor	276

*Grès porcellanato*  
*Porcelain stoneware*  
*Grès cérame coloré*  
*Feinsteinzeug*

  
**TUSCANIA**  
ceramiche



# DECAPÉ

*Grès porcellanato smaltato  
Glazed porcelain stoneware . Grès cérame émaillé . Glasiertes feinsteinzeug*

*effetto legno  
wood-look  
effet bois  
holzoptik*

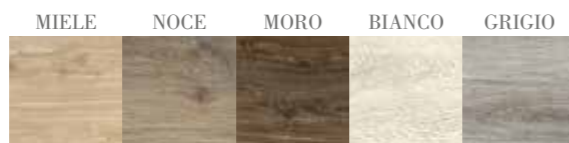

*Una pratica decorativa antica per un prodotto dalle valenze moderne.  
Ovvero una nuova interpretazione delle essenze del legno naturale  
applicata al prodotto ceramico.  
L'effetto superficiale "Decapé" è stato studiato per trasmettere  
armonia e calore alle superfici abitative del terzo millennio.*

*An ancient decorative technique for a product with a modern style.  
A new interpretation of the natural wood essences applied to the ceramic product.  
The "Decapé" surface effect was designed to give harmony and warmth  
to living spaces in the third millennium.*

*Une très ancienne pratique décorative, pour un produit extrêmement actuel.  
C'est-à-dire une nouvelle interprétation des essences du bois naturel  
appliquée au produit céramique.  
Le rendu de la finition "Decapé" a été expressément étudié pour transmettre  
harmonie et chaleur aux surfaces des habitations du troisième millénaire.*

*Eine antike dekorative Verarbeitung für ein Produkt mit modernen Aspekten.  
Beziehungsweise eine neue Interpretation der Essenzen des natürlichen Holzes,  
das dem Keramikprodukt verliehen wird.  
Der Oberflächeneffekt "Decapé" wurde entworfen, um den Wohnflächen  
des dritten Jahrtausends Harmonie und Wärme zu schenken.*







indoor: MORO | 20,3x122,6 cm R\_8"x48" R  
outdoor: COR-STONE FP2 | 61,5x61,5 cm NS\_24"x24" NS

-CG\_226-

DECAPÉ

GRIGIO | 30,5x122,6 cm R\_12"x48" R - 20,3x122,6 cm R\_8"x48" R  
20,3x122,6 cm R outdoor\_8"x48" R outdoor



-CG\_227-



# RE-WOOD

---

*Grès porcellanato smaltato*  
*Glazed porcelain stoneware . Grès cérame émaillé . Glasiertes feinsteinzeug*

*effetto legno*  
*wood-look*  
*effet bois*  
*holzoptik*



---

*Una texture naturale e delicata che trova il giusto abbinamento armonico con ogni tipo di arredamento interno.*  
*Un effetto estetico sorprendente ed esclusivo, che emoziona e aggiunge familiarità alla preziosa intimità della tradizione.*

---

*A natural and delicate texture that beautifully complements any interior decor.*  
*A surprising and exclusive look that brings a fascinating and familiar aspect to the precious intimacy of tradition.*

*Une texture naturelle et discrète qui s'adapte harmonieusement à tous les styles d'intérieur.*  
*Un émouvant rendu esthétique, surprenant et exclusif, qui ajoute une valeur de chaleur familiale à la précieuse intimité de la tradition.*

*Eine natürliche und sanfte Textur, die die richtige harmonische Verbindung mit jedem internen Einrichtungsstil findet.*  
*Ein überraschender und exklusiver ästhetischer Effekt, der Emotionen auslöst und der wertvollen Sphäre der Tradition Vertrautheit verleiht.*





# RE-WOOD

Grès porcellanato smaltato  
Glazed porcelain stoneware  
Grès cérame émaillé  
Glasiertes Feinsteinzeug



R10

HD

V3



HIGH



20,3x122,6 cm R . 8"x48" R

**R** Rettificato  
Rectified

grey



J0S7 | 20,3x122,6 cm 8"x48"

**R** 41,67

moro



J0S8 | 20,3x122,6 cm 8"x48"

**R** 41,67

white



J0S9 | 20,3x122,6 cm 8"x48"

**R** 41,67

pezzi speciali - special pieces - pièces spéciales - formteile



grey



white



moro

battiscopa

6,5x122,6 cm R 2 1/2"x48" R

grey

white

moro

**R**

9,26/PZ

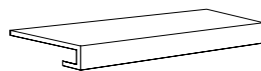

gradino costa retta

30,5x122,6x4 cm 12"x48"x1 3/4"

**163,58/PZ**

grey

white

moro

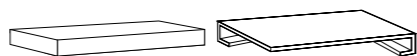

vista frontale

angolare costa retta dx/sx

30,5x122,6x4 cm 12"x48"x1 3/4"

grey

white

moro

vista dal retro

**200,62/PZ**

Note - Notes - Notes - Anmerkungen

I battiscopa vengono venduti a pz. e a scatola completa. Tutti gli altri pezzi speciali vengono venduti al pezzo. I gradini vengono prodotti solo su ordinazione (tempo minimo di consegna 20 gg lavorativi).  
Skirtings are sold by piece and full boxes. All other special trims are sold by piece. Steps are produced only on request (minimum delivery terms of 20 days).  
Les plinthes sont vendues la pièce et par boîte complète. Les autres pièces spéciales sont vendus la pièce. Le plat de marche sont produit sur demande (délai minimum de 20 jours).  
Die Sockelleisten werden pro Stk. und Vollen Kartons verkauft. Stufen und Stufenecken werden nur auf Bestellung produziert (Lieferzeiten mindesten 20 arbeitstagen ab Auftragserteilung).

-CG\_234-

RE-WOOD

Per la disponibilità articolo: [www.tuscaniagres.it](http://www.tuscaniagres.it)  
digitando il codice web segnalato a lato dei formati.  
For the item's availability: [www.tuscaniagres.it](http://www.tuscaniagres.it)  
type the web code reported next to the sizes.  
Pour vérifier la disponibilité de l'article: [www.tuscaniagres.it](http://www.tuscaniagres.it)  
en saisissant le code web indiqué à coté des formats.  
Für die Artikelverfügbarkeit: [www.tuscaniagres.it](http://www.tuscaniagres.it)  
web code eingeben, an der Seite von Formaten angedeutet.

floor: GREY | 20,3x122,6 cm R\_8"x48" R - wall: TRAME MONOFACCIA CLIP COLOR | 20x20 cm\_8"x8"



-CG\_235-

# UNICO

---

*Grès porcellanato smaltato*  
*Glazed porcelain stoneware . Grès cérame émaillé . Glasiertes feinsteinzeug*

*effetto legno*  
*wood-look*  
*effet bois*  
*holzoptik*

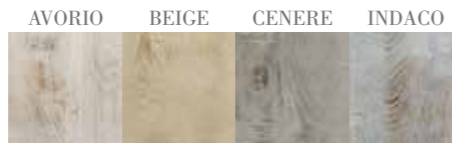

*Non ha eguali nel suo genere. Singolare ed irripetibile, questo prodotto ci riporta al superlativo assoluto della tecnologia ceramica. “Unico” rende omaggio alla naturalezza autentica del legno celebrandone il calore, i toni e le caratteristiche venature.*

*One-of-a-kind. Unique and unrepeatable, this product is the absolute ultimate in ceramic technology.*

*“Unico” pays tribute to the natural authenticity of wood by celebrating its warmth, nuances and veining effects.*

*Sans-pareil. Singulier et irremplaçable, ce produit nous renvoie au superlatif absolu de la technologie céramique.*

*“Unico” rend hommage à l’âme naturellement authentique du bois dont il célèbre l’esprit chaleureux, les nuances et les veinures caractéristiques.*

*Er fürchtet keinen Vergleich. Einzigartig und nicht wiederholbar: Dieses Produkt führt uns zu dem absoluten Superlativ der Keramik-Technologie.*

*“Unico” verehrt die authentische Natürlichkeit des Holzes und zelebriert die Wärme, die Nuancen und die typischen Maserungen.*





CENERE | 20,3x122,6 cm R\_8"x48" R



UNICO

-CG\_238-



-CG\_239-

INDACO | 20,3x122,6 cm R\_8"x48" R

# UNICO

Grès porcellanato smaltato  
Glazed porcelain stoneware  
Grès cérame émaillé  
Glasiertes Feinsteinzeug

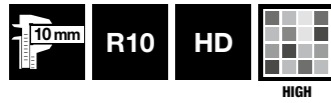

**R** Rettificato  
Rectified

**R**  
20,3x122,6 cm R . 8"x48" R

UNICO  
Per la disponibilità articolo: [www.tuscaniagres.it](http://www.tuscaniagres.it)  
digitando il codice web segnalato a lato dei formati.  
For the item's availability: [www.tuscaniagres.it](http://www.tuscaniagres.it)  
type the web code reported next to the sizes.  
Pour vérifier la disponibilité de l'article: [www.tuscaniagres.it](http://www.tuscaniagres.it)  
en saisissant le code web indiqué à coté des formats.  
Für die Artikelverfügbarkeit: [www.tuscaniagres.it](http://www.tuscaniagres.it)  
web code eingeben, an der Seite von Formaten angedeutet.  
floor: BEIGE | 20,3x122,6 cm R\_8"x48" R  
wall: TRAME MAKÒ COLOR | 20x20 cm N\_8"x8" N

avorio



L2J9 | 20,3x122,6 cm 8"x48" **R** 41,67

cenere



L3J1 | 20,3x122,6 cm 8"x48" **R** 41,67

beige



L3J2 | 20,3x122,6 cm 8"x48" **R** 41,67

indaco



L3J0 | 20,3x122,6 cm 8"x48" **R** 41,67

pezzi speciali - special pieces - pièces spéciales - formteile



avorio



beige



cenere



indaco

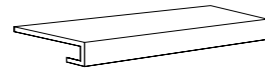

gradino costa retta 12  
30,5x122,6x4 cm 12"x48"x1 3/4" **163,58/PZ**

avorio \_\_\_\_\_  
beige \_\_\_\_\_  
cenere \_\_\_\_\_  
indaco \_\_\_\_\_

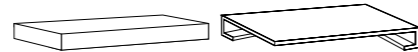

vista frontale      vista dal retro  
angolare costa retta dx/sx  
30,5x122,6x4 cm 12"x48"x1 3/4" **200,62/PZ**

avorio \_\_\_\_\_  
beige \_\_\_\_\_  
cenere \_\_\_\_\_  
indaco \_\_\_\_\_

Note - Notes - Notes - Anmerkungen

I battiscopa vengono venduti a pz. e a scatola completa. Tutti gli altri pezzi speciali vengono venduti al pezzo. I gradini vengono prodotti solo su ordinazione (tempo minimo di consegna 20 gg lavorativi).  
Skirtings are sold by piece and full boxes. All other special trims are sold by piece. Steps are produced only on request (minimum delivery terms of 20 days).  
Les plinthes sont vendues la pièce et par boîte complète. Les autres pièces spéciales sont vendues la pièce. Le plat de marche sont produit sur demande (délai minimum de 20 jours).  
Die Sockelleisten werden pro Stk. und Vollen Kartons verkauft. Stufen und Stufenecken werden nur auf Bestellung produziert (Lieferzeiten mindesten 20 arbeitstagen ab Auftragserteilung).



# GUSHURE

*Grès porcellanato smaltato*  
*Glazed porcelain stoneware . Grès cérame émaillé . Glasiertes feinsteinzeug*

*effetto legno*  
*wood-look*  
*effet bois*  
*holzoptik*



*Naturalness, sfumature, venature e calore del legno antico sono riprodotte con grande attenzione e precisione nella serie “Gushure”, donando un valore aggiunto a qualsiasi tipologia di ambiente tradizionale o di design. Un decoro con sottilissime trame geometriche che si adagiano su un legno stonalizzato, arricchisce la serie, generando un affascinante fusione che dona agli spazi una personalità raffinata ed elegante.*

*All the naturalness, colour fading, grain and the warmth of old wood are reproduced with great attention and precision in the series “Gushure”, to give added value to any traditional or modern setting. These decorative tiles are enriched by ultra-fine geometric patterns engrained on a faded wood effect, for a charming fusion that gives any space a sophisticated, elegant personality.*

*Naturel, nuances, veinures et chaleur du bois ancien Sont reproduits avec grand soin et précision dans la série “Gushure”, apportant une valeur ajoutée à tout type d’espace traditionnel ou design. Un décor aux très fines trames géométriques qui s’étendent sur un bois stonalisé, enrichit la série, engendrant une fusion séduisante qui confère aux espaces une personnalité raffinée et élégante.*

*Natürlichkeit, Farbtöne, Maserung und Wärme von altem Holz werden in der „Gushure“-Serie mit großer Sorgfalt und Präzision wiedergegeben und verleihen jeder Art von traditioneller oder gestalterischer Umgebung einen Mehrwert. Eine Dekoration mit sehr filigranen geometrischen Mustern, auf einem abgetönten Holzgrund bereichert die Serie und erzeugt eine faszinierende Fusion, die den Räumen eine raffinierte und elegante Persönlichkeit verleiht.*



# GUSHURE

Grès porcellanato smaltato  
Glazed porcelain stoneware  
Grès cérame émaillé  
Glasiertes Feinsteinzeug



**R** Rettificato  
Rectified

bone



L2R1 | 20,3x122,6 cm 8"x48" **R** 41,67

nut



L2R0 | 20,3x122,6 cm 8"x48" **R** 41,67

light navy



L2R2 | 20,3x122,6 cm 8"x48" **R** 41,67

decori - decors - décors - dekors

decoro gushure - 20,3x122,6 cm 8"x48" **R**

bone



20,3x122,6 cm 8"x48" **R** 58,64/MQ

nut



20,3x122,6 cm 8"x48" **R** 58,64/MQ

light navy



20,3x122,6 cm 8"x48" **R** 58,64/MQ

sviluppo grafico . design development

nut decoro gushure - 20,3x122,6 cm 8"x48" R **R**



-CG\_244-

# GUSHURE

Per la disponibilità articolo: [www.tuscaniagres.it](http://www.tuscaniagres.it)  
digitando il codice web segnalato a lato dei formati.  
For the item's availability: [www.tuscaniagres.it](http://www.tuscaniagres.it)  
type the web code reported next to the sizes.  
Pour vérifier la disponibilité de l'article: [www.tuscaniagres.it](http://www.tuscaniagres.it)  
en saisissant le code web indiqué à coté des formats.  
Für die Artikelverfügbarkeit: [www.tuscaniagres.it](http://www.tuscaniagres.it)  
web code eingeben, an der Seite von Formaten angedeutet.

GUSHURE BONE decoro | 20,3x122,6 cm R\_8"x48" R



pezzi speciali - special pieces - pièces spéciales - fornteile

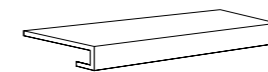

gradino costa retta **12**  
30,5x122,6x4 cm 12"x48"x1<sup>3/4</sup>" **163,58/PZ**

bone  
nut  
light navy

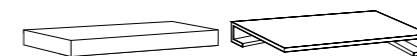

vista frontale      vista dal retro  
angolare costa retta dx/sx  
30,5x122,6x4 cm 12"x48"x1<sup>3/4</sup>" **200,62/PZ**

bone  
nut  
light navy



battiscopa **10**  
6,5x122,6 cm R 2<sup>1/2</sup>"x48" R **R** 9,26/PZ

bone  
nut  
light navy

Note - Notes - Notes - Anmerkungen

I battiscopa vengono venduti a pz. e a scatola completa. Tutti gli altri pezzi speciali vengono venduti al pezzo. I gradini vengono prodotti solo su ordinazione (tempo minimo di consegna 20 gg lavorativi).  
Skirtings are sold by piece and full boxes. All other special trims are sold by piece. Steps are produced only on request (minimum delivery terms of 20 days).  
Les plinthes sont vendues la pièce et par boîte complète. Les autres pièces spéciales sont vendus la pièce. Le plat de marche sont produit sur demande (délai minimum de 20 jours).  
Die Sockelleisten werden pro Stk. und Vollen Kartons verkauft. Stufen und Stufenecken werden nur auf Bestellung produziert (Lieferzeiten mindesten 20 arbeitstagen ab Auftragserteilung).

-CG\_245-

# FJORD

*Grès porcellanato smaltato*  
*Glazed porcelain stoneware . Grès cérame émaillé . Glasiertes feinsteinzeug*

*effetto legno*  
*wood-look*  
*effet bois*  
*holzoptik*



*Seguendo una delle principali tendenze ceramiche del momento, Tuscania propone “Fjord” una serie che rappresenta uno stile di vita attuale, che predilige la ricercatezza e la naturalezza di un materiale ceramico in Gres Porcellanato, ispirato ai legni nordici. Inoltre, la disponibilità di elaborati mosaici, consente la realizzazione di soluzioni creative legate alla tradizione ma di spiccata contemporaneità*

*In line with one of the latest trends in ceramic, Tuscania proposes "Fjord", a series that represents a contemporary way of living that favours more sophisticated, natural products in porcelain stoneware, inspired by Nordic wood essences. Furthermore, thanks to the elaborate mosaics available, creative solutions are possible that are both traditional and ultra-contemporary at the same time.*

*Suivant l'une des principales tendances céramiques du moment, Tuscania propose “Fjord”, une série qui représente un style de vie actuel, privilégiant la sophistication et le naturel d'un matériau céramique en Grès Cérame, inspiré des bois nordiques. En outre, la disponibilité de mosaïques élaborées, permet la réalisation de solutions créatives liées à la tradition mais à la modernité prononcée.*

*In Anlehnung an einen der wichtigsten Keramiktrends der Gegenwart bietet Tuscania „Fjord“ eine Serie an, die einen modernen Lebensstil repräsentiert, der die Raffinesse und Natürlichkeit eines Keramikmaterials aus Feinsteinzeug, das von nordischen Hölzern inspiriert ist, bevorzugt. Darüber hinaus ermöglicht die Verfügbarkeit von aufwendigen Mosaiken die Schaffung von kreativen Lösungen in Verbindung mit der Tradition, die aber deutlich zeitgenössisch bleiben.*





HONNING | 30,5x122,6 cm R\_12"x48" R - 20,3x122,6 cm R\_8"x48" R  
20,3x122,6 cm R outdoor\_8"x48" R outdoor  
elemento "L" monolitico outdoor 15x61x4 cm\_6"x24"x1<sup>3/4</sup>"

-CG\_248-

FJORD

VIT | 30,5x122,6 cm R\_12"x48" R - 20,3x122,6 cm R\_8"x48" R  
VIT mosaico NORGE | 36x32,5 cm\_14<sup>1/2</sup>"x13"



-CG\_249-

BRUN | 30,5x122,6 cm R\_12"x48" R - 20,3x122,6 cm R\_8"x48" R



FJORD

-CG\_250-



-CG\_251-

GRA | 30,5x122,6 cm R\_12"x48" R  
20,3x122,6 cm R\_8"x48" R

# FJORD

Grès porcellanato smaltato  
Glazed porcelain stoneware  
Grès cérame émaillé  
Glasiertes Feinsteinzeug



**R** Rettificato  
Rectified

**RS** Rettificato/Strutturato -  
Rectified/Textured

## honning



<b>I3V7</b>	30,5x122,6 cm 12"x48"	<b>R</b>	41,67
<b>I3V3</b>	20,3x122,6 cm 8"x48"	<b>R</b>	41,67
<b>I2W7</b>	20,3x122,6 cm 8"x48" OUTDOOR	<b>R</b>	43,21
<b>J8F5</b>	22x90 cm 9"x36"	<b>R</b>	38,58
<b>L6U8</b>	19,6x160,0 cm 7 1/2"x62"	<b>R</b>	52,47
<b>J8F4</b>	15x90 cm 6"x36"	<b>R</b>	38,58

<b>FP-2</b>			
<b>L7U1</b>	40x122,6 cm 16"x48" FP2	<b>RS</b>	72,54

## brun



<b>I3V6</b>	30,5x122,6 cm 12"x48"	<b>R</b>	41,67
<b>I3V1</b>	20,3x122,6 cm 8"x48"	<b>R</b>	41,67
<b>J9F7</b>	22x90 cm 9"x36"	<b>R</b>	38,58
<b>L6U6</b>	19,6x160,0 cm 7 1/2"x62"	<b>R</b>	52,47
<b>H8P4</b>	15x90 cm 6"x36"	<b>R</b>	38,58

## vit



<b>I3V5</b>	30,5x122,6 cm 12"x48"	<b>R</b>	41,67
<b>I3V0</b>	20,3x122,6 cm 8"x48"	<b>R</b>	41,67
<b>H3M3</b>	22x90 cm 9"x36"	<b>R</b>	38,58
<b>L6U7</b>	19,6x160,0 cm 7 1/2"x62"	<b>R</b>	52,47
<b>H7S1</b>	15x90 cm 6"x36"	<b>R</b>	38,58

## gra



<b>I3V4</b>	30,5x122,6 cm 12"x48"	<b>R</b>	41,67
<b>I2V8</b>	20,3x122,6 cm 8"x48"	<b>R</b>	41,67
<b>I2V9</b>	20,3x122,6 cm 8"x48" OUTDOOR	<b>R</b>	43,21
<b>J7G8</b>	22x90 cm 9"x36"	<b>R</b>	38,58
<b>L6U9</b>	19,6x160,0 cm 7 1/2"x62"	<b>R</b>	52,47
<b>H9H0</b>	15x90 cm 6"x36"	<b>R</b>	38,58

<b>FP-2</b>			
<b>L7U0</b>	40x122,6 cm 16"x48" FP2	<b>RS</b>	72,54

**FP-2**  
pag. 366

<b>FP2</b>			
<b>RS</b>			
	*40x122,6 cm RS . 16"x48" RS		
			30,5x122,6 cm R . 12"x48" R
			*honning, gra

<b>R</b>			
	15x90 cm R . 6"x36" R		

<b>R</b>			
	20,3x122,6 cm R . 8"x48" R		
	*20,3x122,6 cm R - outdoor .		
	8"x48" R - outdoor		
			*honning, gra

<b>R</b>			
	22x90 cm R . 9"x36" R		

<b>R</b>			
	19,6x160,0 cm R . 7 1/2"x62" R		

inserto sticky 3D - 18,5x59,4 cm 7 1/2"x24" **22,53/PZ**

## honning



## vit



## brun



## gra



**FJORD**  
Per la disponibilità articolo: [www.tuscaniagres.it](http://www.tuscaniagres.it)  
digitando il codice web segnalato a lato dei formati.  
For the item's availability: [www.tuscaniagres.it](http://www.tuscaniagres.it)  
type the web code reported next to the sizes.  
Pour vérifier la disponibilité de l'article: [www.tuscaniagres.it](http://www.tuscaniagres.it)  
en saisissant le code web indiqué à coté des formats.  
Für die Artikelverfügbarkeit: [www.tuscaniagres.it](http://www.tuscaniagres.it)  
web code eingeben, an der Seite von Formaten angedeutet.

decori - decors - décors - dekors  
mosaico norge

36x32,5 cm 14 1/2"x13" **24,54/PZ**

## honning



## vit



## brun



## gra



pezzi speciali - special pieces -  
pièces spéciales - fornteile



honning  
elemento "L" monolitico outdoor  
15x61x4 cm 6"x24"x1 3/4" **33,95/PZ**

honning  
gra

gradino costa retta  
30,5x122,6x4 cm 12"x48"x1 3/4" **163,58/PZ**

honning  
brun  
vit  
gra

vista frontale  
angolare costa retta dx/sx  
30,5x122,6x4 cm 12"x48"x1 3/4" **200,62/PZ**

honning  
brun  
vit  
gra



battiscopa   
6,5x122,6 cm R 2 1/2"x48" R **9,26/PZ**

honning  
brun  
vit  
gra

I battiscopa vengono venduti a pz. e a scatola completa. Tutti gli altri pezzi speciali vengono venduti al pezzo. I gradini vengono prodotti solo su ordinazione (tempo minimo di consegna 20 gg lavorativi).  
Skirtings are sold by piece and full boxes. All other special trims are sold by piece. Steps are produced only on request (minimum delivery terms of 20 days).  
Les plinthes sont vendues la pièce et par boîte complète. Les autres pièces spéciales sont vendus la pièce. Le plat de marche sont produit sur demande (délai minimum de 20 jours).  
Die Sockelleisten werden pro Stk. und Vollen Kartons verkauft. Stufen und Stufenecken werden nur auf Bestellung produziert (Lieferzeiten mindesten 20 arbeitstagen ab Auftragserteilung).



# NORTH WIND

*Grès porcellanato smaltato*  
*Glazed porcelain stoneware . Grès cérame émaillé . Glasiertes feinsteinzeug*

*effetto legno*  
*wood-look*  
*effet bois*  
*holzoptik*



*Trame lignee declinate su cinque colori e svariati formati prendono forma in questa serie, ispirata alle foreste nordiche mitiche e fatate in balia del vento del Nord, creando ambienti di grande fascino. La proposta "Outdoor" inoltre, offre continuità alle pavimentazioni interne proiettandole spontaneamente all'esterno con la massima garanzia di resistenza e durabilità.*

*Wooden textures available in five colours and various formats come alive in this series inspired by the legendary and magical Nordic forests exposed to the northern wind, creating extremely charming spaces. The "Outdoor" variation also offers the possibility of a seamless continuity with indoor flooring, spontaneously projecting it outside with the maximum guarantee of resistance and durability.*

*Trames de bois déclinées en cinq couleurs et divers formats Prennent forme dans cette série, inspirée des forêts nordiques mythiques et magiquessoumises au vent du Nord, créant des atmosphères de grand charme. La proposition "Outdoor", offre en outre une continuité aux sols intérieurs en les projetant spontanément à l'extérieur avec la garantie maximale de résistance et de durabilité.*

*Holztexturen in fünf Farben und verschiedenen Größen verleihen dieser Serie Gestalt, inspiriert sind sie durch die mythischen und geheimnisvollen nordischen Wälder, die dem Nordwind ausgesetzt sind, wodurch Räume von großem Charme entstehen. Das „Outdoor“-Angebot sorgt für Kontinuität mit dem Bodenbelag im Innenbereich, indem er spontan nach außen projiziert wird, mit der maximalen Garantie für Festigkeit und Haltbarkeit.*





floor: BROWN | 22x90 cm R\_9"x36" R - 15x90 cm R\_6"x36" R  
wall: IVORY | 15x90 cm R\_6"x36" R

-CG\_256-

NORTH WIND

OAK | 15x90 cm R\_6"x36" R



-CG\_257-



# NORTH WIND

Grès porcellanato smaltato  
Glazed porcelain stoneware  
Grès cérame émaillé  
Glasiertes Feinsteinzeug



**R** Rettificato  
Rectified

**RS** Rettificato/Strutturato -  
Rectified/Textured

FP2  
pag. 368

**FP2**  
**RS**

\*40x122,6 cm RS . 16"x48" RS  
\*grey, brown, melange

**R**

20,3x122,6 cm R . 8"x48" R  
\*20,3x122,6 cm R - outdoor .  
8"x48" R - outdoor  
\*grey, brown

**R**

30,5x122,6 cm R . 12"x48" R

**R**

15x90 cm R . 6"x36" R  
\*15x90 cm R - outdoor .  
6"x36" R - outdoor  
\*grey, brown, melange, ivory

**R**

22x90 cm R . 9"x36" R

**R**

19,6x160,0 cm R . 7 1/2"x62" R

**R**

15x61 cm R . 6"x24" R  
\*15x61 cm R - outdoor .  
6"x24" R - outdoor  
\*grey, brown, ivory

NORTH WIND  
Per la disponibilità articolo: [www.tuscaniagres.it](http://www.tuscaniagres.it)  
digitando il codice web segnalato a lato dei formati.  
For the item's availability: [www.tuscaniagres.it](http://www.tuscaniagres.it)  
type the web code reported next to the sizes.  
Pour vérifier la disponibilité de l'article: [www.tuscaniagres.it](http://www.tuscaniagres.it)  
en saisissant le code web indiqué à coté des formats.  
Für die Artikelverfügbarkeit: [www.tuscaniagres.it](http://www.tuscaniagres.it)  
web code eingeben, an der Seite von Formaten angedeutet.

## oak



<b>J7K2</b>	30,5x122,6 cm 12"x48"	<b>R</b>	<b>41,67</b>
<b>I1S7</b>	20,3x122,6 cm 8"x48"	<b>R</b>	<b>41,67</b>
<b>I0D2</b>	22x90 cm 9"x36"	<b>R</b>	<b>38,58</b>
<b>L7U2</b>	19,6x160,0 cm 7 1/2"x62"	<b>R</b>	<b>52,47</b>
<b>I0D7</b>	15x90 cm 6"x36"	<b>R</b>	<b>38,58</b>
<b>J0Q8</b>	15x61 cm 6"x24"	<b>R</b>	<b>26,23</b>

## brown



<b>J1K1</b>	30,5x122,6 cm 12"x48"	<b>R</b>	<b>41,67</b>
<b>I1S4</b>	20,3x122,6 cm 8"x48"	<b>R</b>	<b>41,67</b>
<b>L8U3</b>	20,3x122,6 cm 8"x48" OUTDOOR	<b>R</b>	<b>43,21</b>
<b>I9C8</b>	22x90 cm 9"x36"	<b>R</b>	<b>38,58</b>
<b>L7U3</b>	19,6x160,0 cm 7 1/2"x62"	<b>R</b>	<b>52,47</b>
<b>I0D3</b>	15x90 cm 6"x36"	<b>R</b>	<b>38,58</b>
<b>I7D1</b>	15x90 cm 6"x36" OUTDOOR	<b>R</b>	<b>40,12</b>
<b>J0Q9</b>	15x61 cm 6"x24"	<b>R</b>	<b>26,23</b>
<b>J1Q0</b>	15x61 cm 6"x24" OUTDOOR	<b>R</b>	<b>27,77</b>

FP2

**L7U7** 40x122,6 cm 16"x48" FP2 **RS** **72,54**

## grey



<b>J1J9</b>	30,5x122,6 cm 12"x48"	<b>R</b>	<b>41,67</b>
<b>I1S3</b>	20,3x122,6 cm 8"x48"	<b>R</b>	<b>41,67</b>
<b>L8U2</b>	20,3x122,6 cm 8"x48" OUTDOOR	<b>R</b>	<b>43,21</b>
<b>I0D0</b>	22x90 cm 9"x36"	<b>R</b>	<b>38,58</b>
<b>L7U5</b>	19,6x160,0 cm 7 1/2"x62"	<b>R</b>	<b>52,47</b>
<b>I0D5</b>	15x90 cm 6"x36"	<b>R</b>	<b>38,58</b>
<b>I6D9</b>	15x90 cm 6"x36" OUTDOOR	<b>R</b>	<b>40,12</b>
<b>J0Q5</b>	15x61 cm 6"x24"	<b>R</b>	<b>26,23</b>
<b>J0Q6</b>	15x61 cm 6"x24" OUTDOOR	<b>R</b>	<b>27,77</b>

FP2

**L7U8** 40x122,6 cm 16"x48" FP2 **RS** **72,54**

## ivory



<b>J7K1</b>	30,5x122,6 cm 12"x48"	<b>R</b>	<b>41,67</b>
<b>I1S5</b>	20,3x122,6 cm 8"x48"	<b>R</b>	<b>41,67</b>
<b>I9C9</b>	22x90 cm 9"x36"	<b>R</b>	<b>38,58</b>
<b>L7U6</b>	19,6x160,0 cm 7 1/2"x62"	<b>R</b>	<b>52,47</b>
<b>I0D4</b>	15x90 cm 6"x36"	<b>R</b>	<b>38,58</b>
<b>L8U0</b>	15x90 cm 6"x36" OUTDOOR	<b>R</b>	<b>40,12</b>
<b>J0Q3</b>	15x61 cm 6"x24"	<b>R</b>	<b>26,23</b>
<b>J8U1</b>	15x61 cm 6"x24" OUTDOOR	<b>R</b>	<b>27,77</b>

## melange



<b>J7K3</b>	30,5x122,6 cm 12"x48"	<b>R</b>	<b>41,67</b>
<b>I1S6</b>	20,3x122,6 cm 8"x48"	<b>R</b>	<b>41,67</b>
<b>I0D1</b>	22x90 cm 9"x36"	<b>R</b>	<b>38,58</b>
<b>L7U4</b>	19,6x160,0 cm 7 1/2"x62"	<b>R</b>	<b>52,47</b>
<b>I0D6</b>	15x90 cm 6"x36"	<b>R</b>	<b>38,58</b>
<b>I7D0</b>	15x90 cm 6"x36" OUTDOOR	<b>R</b>	<b>40,12</b>
<b>J0Q7</b>	15x61 cm 6"x24"	<b>R</b>	<b>26,23</b>

FP2

**L7U9** 40x122,6 cm 16"x48" FP2 **RS** **72,54**

rivestimento coordinato - matching wall tiles - faïences coordonnées - koordinierte wandfliesen:

NORTH WIND 20x50 cm 8"x20" - Biccottura tradizionale . Traditional double fired . Traditionnelle double feue . Zweibrandfliesen **8 mm** - pag. 378

ivory



oak



white



grey



# NORTH WIND

NORTH WIND

IVORY | 20,3x122,6 cm R\_8"x48" R



GREY | 15x90 cm R outdoor\_6"x36" R outdoor  
elemento "L" monolitico outdoor 15x61x4 cm\_6"x24"x1<sup>3/4</sup>"



pezzi speciali - special pieces - pièces spéciales - formteile

decori - decors - décors - dekors

stripe monocolora 18 tessere 5x10 - 30x30 cm 12"x12"  13,27/PZ



mosaico mix 36 tessere 5x5  13,27/PZ

30x30 cm 12"x12"



stripe mix 18 tessere 5x10  13,27/PZ

30x30 cm 12"x12"

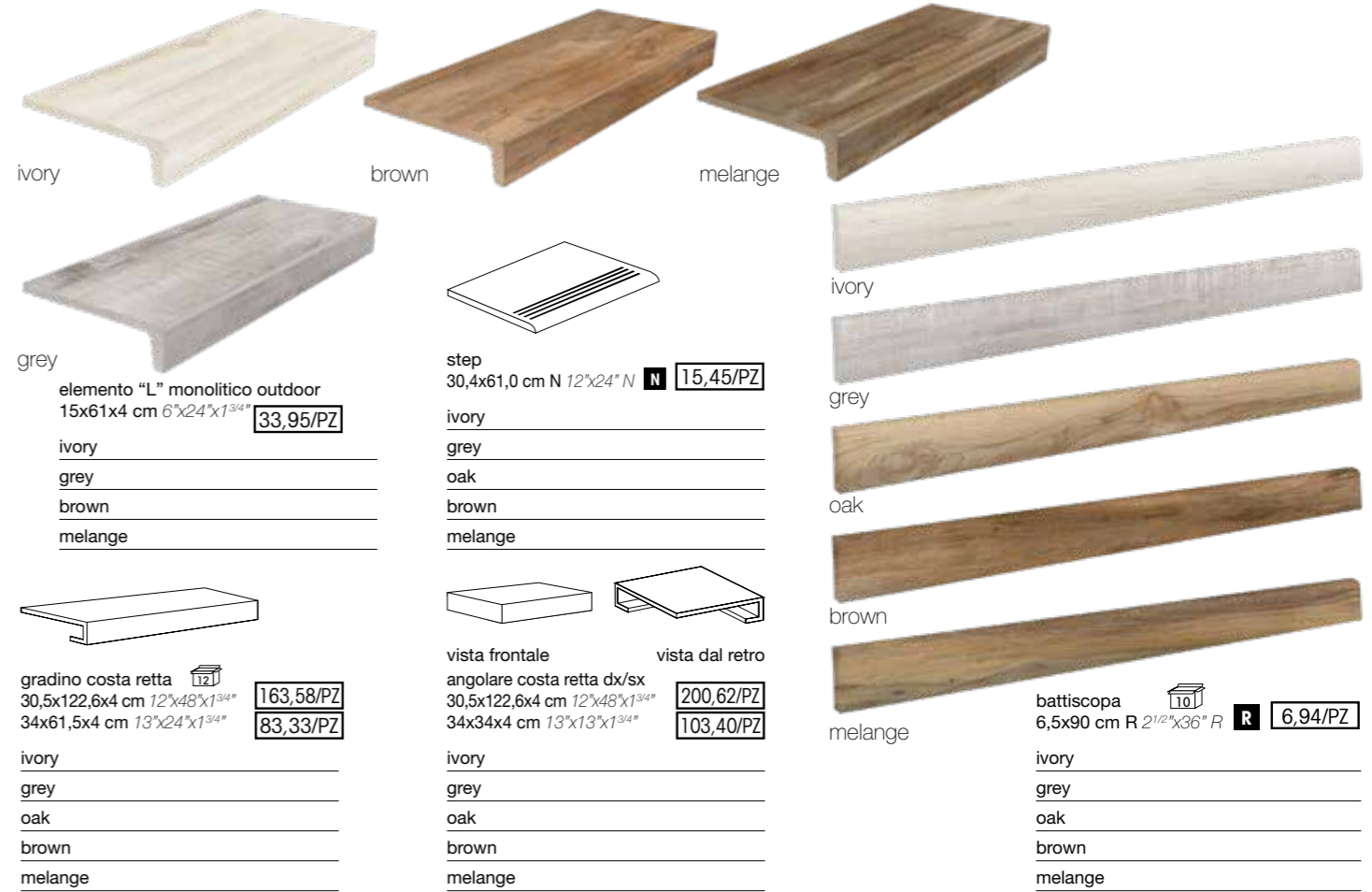

Note - Notes - Notes - Anmerkungen  
I battiscopa vengono venduti a pz. e a scatola completa. Tutti gli altri pezzi speciali vengono venduti al pezzo. I gradini vengono prodotti solo su ordinazione (tempo minimo di consegna 20 gg lavorativi).  
Skirtings are sold by piece and full boxes. All other special trims are sold by piece. Steps are produced only on request (minimum delivery terms of 20 days).  
Les plinthes sont vendues la pièce et par boîte complète. Les autres pièces spéciales sont vendus la pièce. Le plat de marche sont produit sur demande (délai minimum de 20 jours).  
Die Sockelleisten werden pro Stk. und Vollen Kartons verkauft. Stufen und Stufenecken werden nur auf Bestellung produziert (Lieferzeiten mindesten 20 arbeitstagen ab Auftragserteilung).

# NAVAJO

*Grès porcellanato smaltato*  
*Glazed porcelain stoneware . Grès cérame émaillé . Glasiertes feinsteinzeug*

*effetto legno*  
*wood-look*  
*effet bois*  
*holzoptik*



*La caratteristica principale di questa serie è l'aspetto caldo ed avvolgente del legno attraverso colori reali. Nodi e struttura superficiale concorrono a definirne la vocazione rustica ma comunque versatile nella capacità d'adattarsi a diversi stili d'arredo.*

*The main characteristic of this series is the warm, cosy appearance of wood through realistic colours. The knots and the surface texture work together to define the rustic nature of the material, but are still versatile in their ability to adapt to different furnishing styles.*

*La caractéristique principale de cette série est son aspect chaud et enveloppant du bois apporté par des couleurs réelles. Nœuds et structure de surface contribuent à en définir la vocation rustique mais néanmoins polyvalente dans sa capacité à s'adapter à différents styles d'ameublement.*

*Das Hauptmerkmal dieser Serie ist die warme und gemütliche Holzoptik durch naturgetreue Farben. Astlöcher und die Oberflächenstruktur sorgen für einen rustikalen Charakter, sie sind aber gleichzeitig vielseitig in ihrer Anpassungsfähigkeit an unterschiedliche Einrichtungsstile.*





# NAVAJO

Grès porcellanato smaltato  
Glazed porcelain stoneware  
Grès cérame émaillé  
Glasiertes feinsteinzeug



**R** Rettificato  
Rectified

**R**

20,3x122,6 cm R . 8"x48" R  
\*20,3x122,6 cm R - outdoor . 8"x48" R - outdoor  
\*brown, grey

NAVAJO  
Per la disponibilità articolo: [www.tuscaniagres.it](http://www.tuscaniagres.it)  
digitando il codice web segnalato a lato dei formati.  
For the item's availability: [www.tuscaniagres.it](http://www.tuscaniagres.it)  
type the web code reported next to the sizes.  
Pour vérifier la disponibilité de l'article: [www.tuscaniagres.it](http://www.tuscaniagres.it)  
en saisissant le code web indiqué à côté des formats.  
Für die Artikelverfügbarkeit: [www.tuscaniagres.it](http://www.tuscaniagres.it)  
web code eingeben, an der Seite von Formaten angedeutet.

decori - decors - décors - dekors

sand



I1S2 | 20,3x122,6 cm 8"x48" **R** 38,58

brown



I0S9 | 20,3x122,6 cm 8"x48" **R** 38,58  
I0S8 | 20,3x122,6 cm 8"x48" OUTDOOR **R** 40,12

stripe 18 tessere 5x10 - 30x30 cm 12"x12" 13,27/PZ

sand



melange



brown



grey

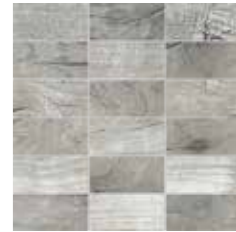

melange



I1S1 | 20,3x122,6 cm 8"x48" **R** 38,58

grey



I1S0 | 20,3x122,6 cm 8"x48" **R** 38,58  
J3H1 | 20,3x122,6 cm 8"x48" OUTDOOR **R** 40,12

pezzi speciali - special pieces - pièces spéciales - formteile



brown

elemento "L" monolitico outdoor  
15x61x4 cm 6"x24"x1<sup>3/4</sup>" **33,95/PZ**

brown

grey



grey

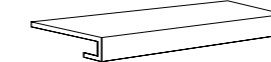

gradino costa retta   
30,5x122,6x4 cm 12"x48"x1<sup>3/4</sup>" **163,58/PZ**

sand

brown

melange

grey



vista frontale vista dal retro  
angolare costa retta dx/sx  
30,5x122,6x4 cm 12"x48"x1<sup>3/4</sup>" **200,62/PZ**

sand

brown

melange

grey



sand



brown



melange

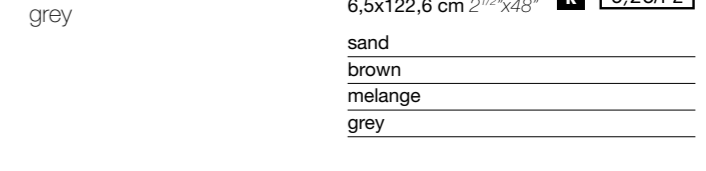

grey

battiscopa   
6,5x122,6 cm 2<sup>1/2</sup>"x48" **R** 9,26/PZ

sand

brown

melange

grey



BROWN | 20,3x122,6 cm R outdoor\_8"x48" R outdoor  
elemento "L" monolitico outdoor 15x61x4 cm\_6"x24"x1<sup>3/4</sup>"

Note - Notes - Notes - Anmerkungen  
I battiscopa vengono venduti a pz. e a scatola completa. Tutti gli altri pezzi speciali vengono venduti al pezzo. I gradini vengono prodotti solo su ordinazione (tempo minimo di consegna 20 gg lavorativi).  
Skirtings are sold by piece and full boxes. All other special trims are sold by piece. Steps are produced only on request (minimum delivery terms of 20 days).  
Les plinthes sont vendues la pièce et par boîte complète. Les autres pièces spéciales sont vendus la pièce. Le plat de marche sont produit sur demande (délai minimum de 20 jours).  
Die Sockelleisten werden pro Stk. und Vollen Kartons verkauft. Stufen und Stufenecken werden nur auf Bestellung produziert (Lieferzeiten mindesten 20 Arbeitstagen ab Auftragserteilung).



# THUNDERWOOD

*Grès porcellanato smaltato*  
*Glazed porcelain stoneware . Grès cérame émaillé . Glasiertes feinsteinzeug*

*effetto legno*  
*wood-look*  
*effet bois*  
*holzoptik*



*L'esaltazione delle venature e della struttura e la voluta ed accentuata diversificazione e stonalizzazione cromatica, rende questa serie originale ed esclusiva.*

*Le sfumature marcate, dall'antico sapore vintage, hanno definito un legno di grande personalità e carattere che genera superfici alternative ed inattese.*

*The wood grains, texture and the intentionally strong diversification and colour fading make this series original and exclusive.*

*The distinct colour fading had a vintage appeal and defines the effect of wood with a bold personality that creates alternative, unexpected surfaces.*

*La mise en valeur des veinures et de la structure ainsi que la diversification et la stonalisation chromatique recherchées et accentuées, rendent cette série originale et exclusive.*

*Les nuances marquées, à l'antique saveur vintage, ont défini un bois de grande personnalité et caractère qui engendre des surfaces alternatives et inattendues.*

*Maserung und Struktur stehen hier im Vordergrund und machen zusammen mit einer akzentuierten Farbvielfalt und Farbschattierung diese Serie originell und exklusiv.*

*Die markanten Farbtöne sorgen für Vintage-Look und definieren ein Holz mit großer Persönlichkeit und starkem Charakter, so entstehen alternative und unerwartete Oberflächen.*

-CG\_270-

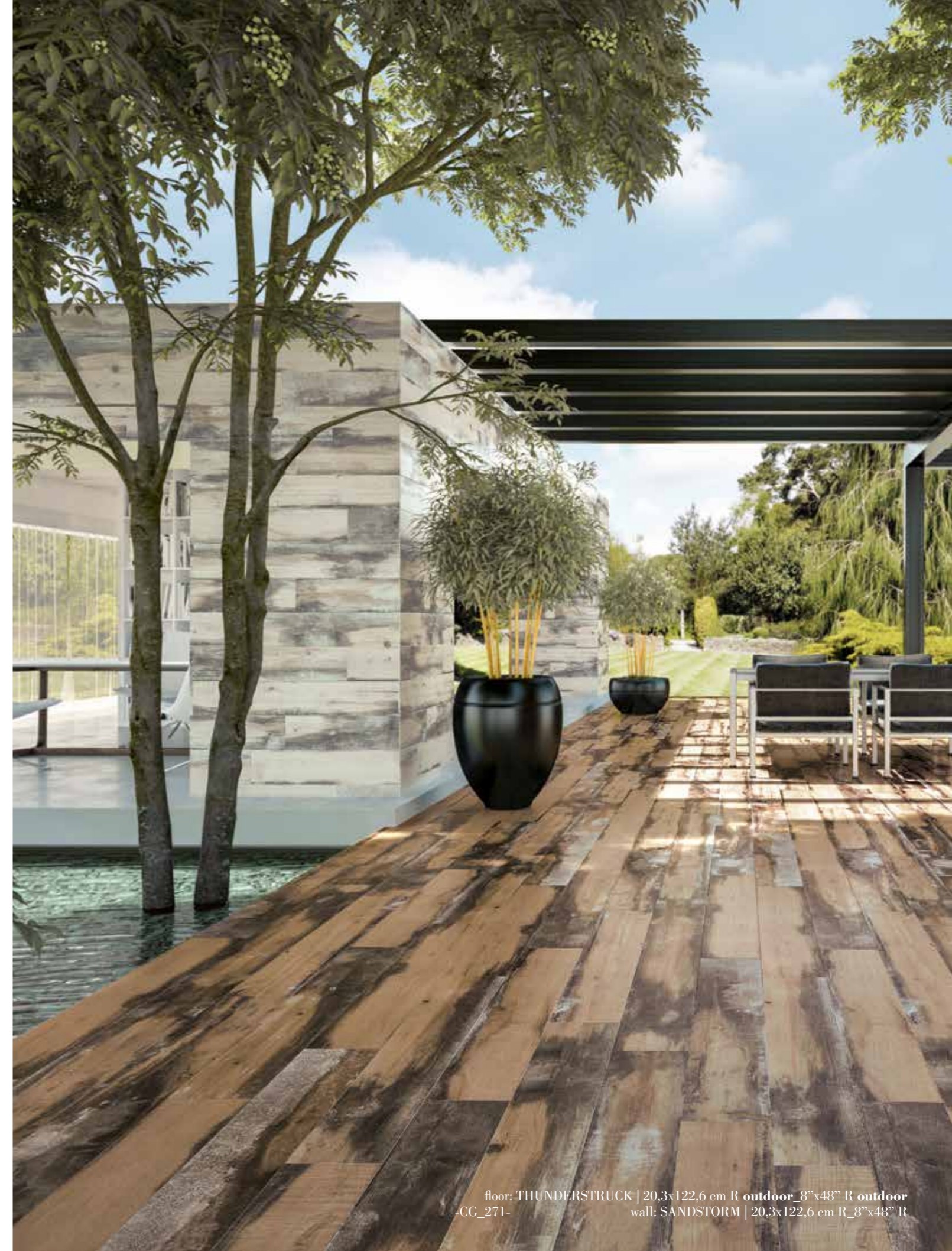

floor: THUNDERSTRUCK | 20,3x122,6 cm R outdoor\_8"x48" R outdoor  
-CG\_271- wall: SANDSTORM | 20,3x122,6 cm R\_8"x48" R



SANDSTORM | 20,3x122,6 cm R outdoor\_8"x48" R outdoor

THUNDERWOOD

floor: FIERYCHERRY | 20,3x122,6 cm R\_8"x48" R  
wall: SANDSTORM | 20,3x122,6 cm R\_8"x48" R



# THUNDERWOOD

Grès porcellanato smaltato  
Glazed porcelain stoneware  
Grès cérame émaillé  
Glasiertes Feinsteinzeug



**R** Rettificato  
Rectified

**RS** Rettificato/Strutturato -  
Rectified/Textured

FP2  
pag. 370



\*40x122,6 cm RS . 16"x48" RS  
\*sandstorm, thunderstruck



20,3x122,6 cm R . 8"x48" R  
20,3x122,6 cm R - outdoor .  
8"x48" R - outdoor

## THUNDERWOOD

Per la disponibilità articolo: [www.tuscaniagres.it](http://www.tuscaniagres.it)  
digitando il codice web segnalato a lato dei formati.  
For the item's availability: [www.tuscaniagres.it](http://www.tuscaniagres.it)  
type the web code reported next to the sizes.  
Pour vérifier la disponibilité de l'article: [www.tuscaniagres.it](http://www.tuscaniagres.it)  
en saisissant le code web indiqué à coté des formats.  
Für die Artikelverfügbarkeit: [www.tuscaniagres.it](http://www.tuscaniagres.it)  
web code eingeben, an der Seite von Formaten angedeutet.

decori - decors - décors - dekors

## sandstorm



I3U2 | 20,3x122,6 cm 8"x48" **R** 41,67

I3U3 | 20,3x122,6 cm 8"x48" OUTDOOR **R** 43,21

FP2  
L2W2 | 40x122,6 cm 16"x48" FP2 **RS** 72,54

## thunderstruck



I5U2 | 20,3x122,6 cm 8"x48" **R** 41,67

I3U4 | 20,3x122,6 cm 8"x48" OUTDOOR **R** 43,21

FP2  
L2W3 | 40x122,6 cm 16"x48" FP2 **RS** 72,54

## fierycherry



I2T6 | 20,3x122,6 cm 8"x48" **R** 41,67

I0V8 | 20,3x122,6 cm 8"x48" OUTDOOR **R** 43,21

mosaico treccia - 20x60 cm 8"x24" **5** 21,60/PZ

## sandstorm



## thunderstruck



## fierycherry



pezzi speciali - special pieces - pièces spéciales - formteile



sandstorm  
elemento "L" monolitico outdoor  
15x61x4 cm 6"x24"x1<sup>3/4</sup>" **33,95/PZ**

sandstorm  
thunderstruck  
fierycherry

gradino costa retta **12**  
30,5x122,6x4 cm 12"x48"x1<sup>3/4</sup>" **163,58/PZ**

sandstorm  
thunderstruck  
fierycherry

vista frontale      vista dal retro  
angolare costa retta dx/sx  
30,5x122,6x4 cm 12"x48"x1<sup>3/4</sup>" **200,62/PZ**

sandstorm  
thunderstruck  
fierycherry



battiscopa **R** **10**  
6,5x122,6 cm R 2<sup>1/2</sup>"x48" R **9,26/PZ**

sandstorm  
thunderstruck  
fierycherry

Note - Notes - Notes - Anmerkungen

I battiscopa vengono venduti a pz. e a scatola completa. Tutti gli altri pezzi speciali vengono venduti al pezzo. I gradini vengono prodotti solo su ordinazione (tempo minimo di consegna 20 gg lavorativi).  
Skirtings are sold by piece and full boxes. All other special trims are sold by piece. Steps are produced only on request (minimum delivery terms of 20 days).  
Les plinthes sont vendues la pièce et par boîte complète. Les autres pièces spéciales sont vendus la pièce. Le plat de marche sont produit sur demande (délai minimum de 20 jours).  
Die Sockelleisten werden pro Stk. und Vollen Kartons verkauft. Stufen und Stufenecken werden nur auf Bestellung produziert (Lieferzeiten mindesten 20 arbeitstagen ab Auftragserteilung).

# WOODY FLOOR

*Grès porcellanato smaltato*  
*Glazed porcelain stoneware . Grès cérame émaillé . Glasiertes feinsteinzeug*

*effetto legno*  
*wood-look*  
*effet bois*  
*holzoptik*



*“Woody Floor” si presenta come pura interpretazione estetica delle più rare essenze del legno e basandosi su calde cadenze cromatiche crea effetti decorativi piacevoli ed inconsueti.*

*Woody Floor significa abitare naturalmente nel calore domestico: un'esigenza sempre più sentita e ricercata al giorno d'oggi.*

*"Woody Floor" has the appearance of a pure reproduction of the rarest wood essences. With its warm colours it creates pleasant and unusual decorative effects.*

*Woody Floor means living naturally in the warmth of one's own home: something that is now in increasing demand.*

*“Woody Floor” se présente comme une pure interprétation esthétique des essences de bois les plus rares et, en s'appuyant sur les chaudes modulations chromatiques crée des effets décoratifs agréables et inhabituels.*

*Woody Floor signifie habiter de manière naturelle dans la chaleur domestique : un besoin toujours plus ressenti et recherché aujourd'hui*

*„Woody Floor“ ist eine rein ästhetische Interpretation seltener Holzarten und schafft auf der Basis warmer chromatischer Kadenzen eine angenehme und ungewöhnliche Dekorwirkung. Woody Floor bedeutet, im Einklang mit der Natur und in einem gemütlichen Zuhause zu leben: ein Bedürfnis, das heute zunehmend spürbar und gefragt ist.*



# WOODY FLOOR

Grès porcellanato smaltato  
Glazed porcelain stoneware  
Grès cérame émaillé  
Glasiertes Feinsteinzeug

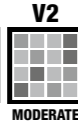

15x61 cm R . 6"x24" R  
\*15x61 cm R - outdoor . 6"x24" R - outdoor  
\*grigio, beige

## avorio



J1F1 | 15x61 cm 6"x24" **R** 26,23

## beige



J1F2 | 15x61 cm 6"x24" **R** 26,23  
J1F3 | 15x61 cm 6"x24" OUTDOOR **R** 27,77

## grigio



J0F9 | 15x61 cm 6"x24" **R** 26,23  
J1F0 | 15x61 cm 6"x24" OUTDOOR **R** 27,77

## noce



I2L5 | 15x61 cm 6"x24" **R** 26,23

pezzi speciali - special pieces - pièces spéciales - formteile



avorio



grigio



beige



noce

battiscopa **R** 4,78/PZ  
6,5x61,0 cm R 2 1/2"x24" R

avorio  
grigio  
beige  
noce

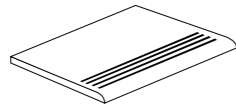

step  
30,4x61,0 cm N 12"x24" N **N** 15,45/PZ

avorio  
grigio  
beige  
noce



gradino costa retta  
30,4x61,0x4 cm 12"x24"x1 3/4" **N** 83,33/PZ

avorio  
grigio  
beige  
noce



grigio

beige

elemento "L" monolitico outdoor  
15x30x4 cm 6"x12"x1 3/4" **N** 10,80/PZ

grigio  
beige

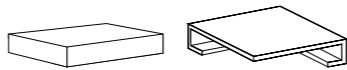

vista frontale  
angolare costa retta dx/sx  
30,4x30,4x4 cm N 12"x12"x1 3/4" N 103,40/PZ

avorio  
grigio  
beige  
noce

Note - Notes - Notes - Anmerkungen

I battiscopa vengono venduti a pz. e a scatola completa. Tutti gli altri pezzi speciali vengono venduti al pezzo. I gradini vengono prodotti solo su ordinazione (tempo minimo di consegna 20 gg lavorativi).

Skirtings are sold by piece and full boxes. All other special trims are sold by piece. Steps are produced only on request (minimum delivery terms of 20 days).

Les plinthes sont vendues la pièce et par boîte complète. Les autres pièces spéciales sont vendus la pièce. Le plat de marche sont produit sur demande (délai minimum de 20 jours).

Die Sockelleisten werden pro Stk. und Vollen Kartons verkauft. Stufen und Stufenecken werden nur auf Bestellung produziert (Lieferzeiten mindesten 20 arbeitstagen ab Auftragserteilung).

# WOODY FLOOR

Per la disponibilità articolo: [www.tuscaniagres.it](http://www.tuscaniagres.it)  
digitando il codice web segnalato a lato dei formati.  
For the item's availability: [www.tuscaniagres.it](http://www.tuscaniagres.it)  
type the web code reported next to the sizes.  
Pour vérifier la disponibilité de l'article: [www.tuscaniagres.it](http://www.tuscaniagres.it)  
en saisissant le code web indiqué à côté des formats.  
Für die Artikelverfügbarkeit: [www.tuscaniagres.it](http://www.tuscaniagres.it)  
web code eingeben, an der Seite von Formaten angedeutet.

BEIGE | 15x61 cm R outdoor\_6"x24" R outdoor - elemento "L" monolitico outdoor 15x30x4 cm\_6"x12"x1 3/4"

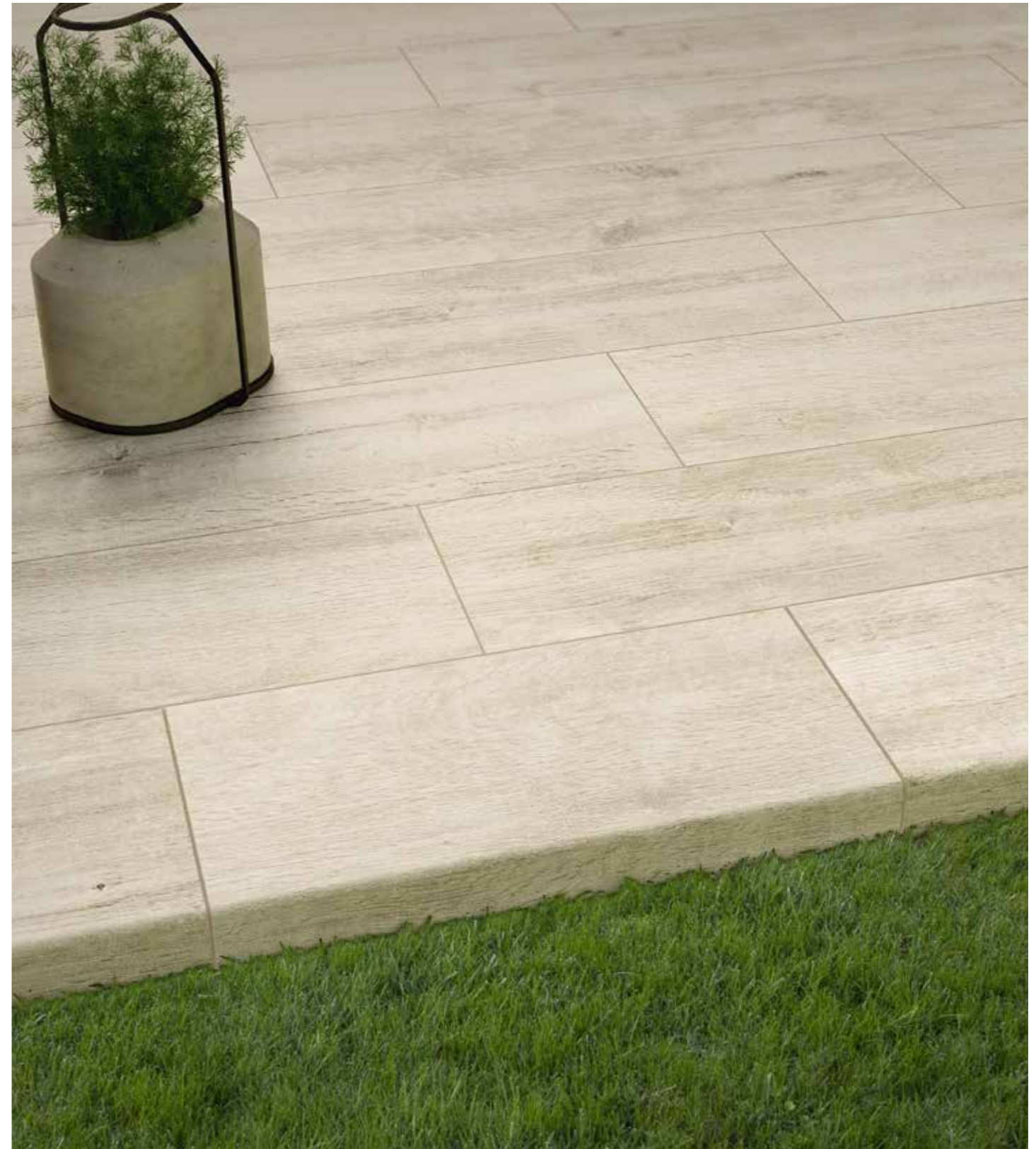

# KOUROS

*Grès porcellanato impasto colorato*

*Color body porcelain stoneware . Grès cérame coloré dans la masse . Durchgefärbtes feinsteinzeug*

*effetto legno  
wood-look  
effet bois  
holzoptik*



*I pavimenti in legno a "cassettoni", tipici del Settecento, da sempre occupano un posto d'onore nei modi di allestire e vivere la casa. Godendo di un' antica tradizione nell' arredamento domestico si ripropongono oggi in gres porcellanato, materiale d'eccellenza e di grande attualità. I listoni in abbinamento valorizzando l'effetto vintage del materiale.*

*The wooden "cassettoni" layout typical in the seventeenth century have always enjoyed an elite position in home style and home living.*

*Following an antique home furnishing tradition, these floors are now re-proposed in porcelain stoneware, a very popular material with outstanding characteristics. The matching slats enhance the vintage effects of the material.*

*Les parquets "à caissons", typiques du 18<sup>ème</sup> siècle, occupent depuis toujours une place de choix dans les façons d'aménager et de vivre la maison.*

*Bénéficiant d'une longue tradition dans l'ameublement domestique, ils sont proposés aujourd'hui en grès cérame, matériau d'excellence et de grande actualité. Les parquets coordonnés mettent en valeur l'effet vintage du matériau.*

*Die Holzfußböden mit „Kassette“ sind typisch für das 18. Jahrhundert, haben schon immer einen Ehrenplatz bei der Einrichtung und dem Wohnen des Hauses eingenommen. Sie haben eine alte Tradition in der Wohnungseinrichtung und sind jetzt in Feinsteinzeug erhältlich, einem Material von höchster Qualität und großer Aktualität. Die passenden Dielen verstärken den Vintage-Effekt des Materials.*



# KOUROS

Impasto Colorato  
Colored Body  
Masse Colorée  
Durchgefärbt



R10

HD

V2

MODERATE

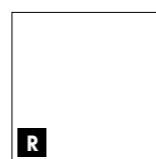

75x75 cm R . 30"x30" R

**R** Rettificato  
Rectified

white



H9T6 | 75x75 cm 30"x30" **R** 32,41

sand



H0U5 | 75x75 cm 30"x30" **R** 32,41

grey



I6U8 | 75x75 cm 30"x30" **R** 32,41

brown



H9T5 | 75x75 cm 30"x30" **R** 32,41

## KOUROS

Per la disponibilità articolo: [www.tuscaniagres.it](http://www.tuscaniagres.it)  
digitando il codice web segnalato a lato dei formati.  
For the item's availability: [www.tuscaniagres.it](http://www.tuscaniagres.it)  
type the web code reported next to the sizes.  
Pour vérifier la disponibilité de l'article: [www.tuscaniagres.it](http://www.tuscaniagres.it)  
en saisissant le code web indiqué à coté des formats.  
Für die Artikelverfügbarkeit: [www.tuscaniagres.it](http://www.tuscaniagres.it)  
web code eingeben, an der Seite von Formaten angedeutet.

WHITE | 75x75 cm R\_30"x30" R



# CHALET

---

*Grès porcellanato smaltato*  
*Glazed porcelain stoneware . Grès cérame émaillé . Glasiertes feinsteinzeug*

*effetto legno*  
*wood-look*  
*effet bois*  
*holzoptik*



*Un inno ai segni ed alle cromie dei classici pavimenti in legno.  
Un progetto che ne esalta le venature eleganti e senza tempo,  
che trasmettono armonia, calore e bellezza.  
Il risultato è suggestivo ed inaspettato, in grado di definire  
superfici sorprendenti ed assolutamente di grande stile.*

---

*A tribute to the markings and colours of classic wooden flooring.  
This project exalts the elegant, timeless grains of wood  
that convey harmony, warmth and beauty.  
The result is suggestive and unexpected, and able to define  
astonishing, extremely stylish surfaces.*

*Un hymne aux signes et aux couleurs des classiques parquets en bois.  
Un projet qui en exalte les veinures élégantes et intemporelles,  
qui apportent harmonie, chaleur et beauté.  
Le résultat est suggestif et inattendu, à même de définir  
des surfaces surprenantes et résolument de grand style.*

*Eine Hymne an die Zeichen und Farben klassischer Holzböden.  
Ein Projekt, das elegante und zeitlose Äderungen hervorhebt,  
die Harmonie, Wärme und Schönheit vermitteln.  
Das Ergebnis ist auffallend und unerwartet in der Lage,  
überraschende Oberflächen und einen absolut tollen Stil zu definieren.*





# CHALET

Grès porcellanato smaltato  
Glazed porcelain stoneware  
Grès cérame émaillé  
Glasiertes Feinsteinzeug



**N** Naturale  
Natural



30,8x61,5 cm N . 12"x24" N  
30,8x61,5 cm N - outdoor .  
12"x24" N - outdoor

CHALET  
Per la disponibilità articolo: [www.tuscaniagres.it](http://www.tuscaniagres.it)  
digitando il codice web segnalato a lato dei formati.  
For the item's availability: [www.tuscaniagres.it](http://www.tuscaniagres.it)  
type the web code reported next to the sizes.  
Pour vérifier la disponibilité de l'article: [www.tuscaniagres.it](http://www.tuscaniagres.it)  
en saisissant le code web indiqué à coté des formats.  
Für die Artikelverfügbarkeit: [www.tuscaniagres.it](http://www.tuscaniagres.it)  
web code eingeben, an der Seite von Formaten angedeutet.

sand



L7J3 | 30,8x61,5 cm 12"x24" **N** **20,99**

L7J8 | 30,8x61,5 cm 12"x24" OUTDOOR **N** **22,22**

white



L7J4 | 30,8x61,5 cm 12"x24" **N** **20,99**

L7J9 | 30,8x61,5 cm 12"x24" OUTDOOR **N** **22,22**

brown



L7J5 | 30,8x61,5 cm 12"x24" **N** **20,99**

L8J0 | 30,8x61,5 cm 12"x24" OUTDOOR **N** **22,22**

grey



L7J6 | 30,8x61,5 cm 12"x24" **N** **20,99**

L7J7 | 30,8x61,5 cm 12"x24" OUTDOOR **N** **22,22**

decori - decors - décors - dekors

mosaico monocolor 36 tessere 5x5 - 30x30 cm 12"x12" **13,27/PZ**

sand



brown

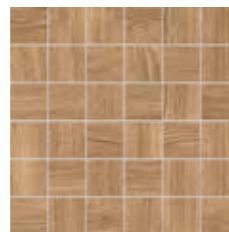

white

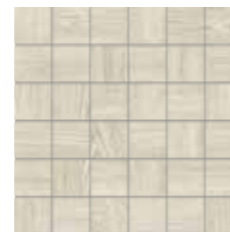

grey

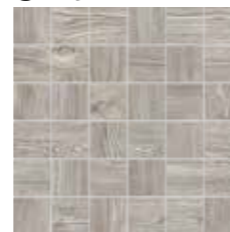

GREY | 30,8x61,5 cm N\_12"x24" N - elemento "L" monolitico outdoor 15x61x4 cm\_6"x24"x1<sup>3/4</sup>"



pezzi speciali - special pieces - pièces spéciales - formteile

sand	brown	white	sand
elemento "L" monolitico outdoor 15x61x4 cm 6"x24"x1 <sup>3/4</sup> " <b>33,95/PZ</b>			
sand			brown
brown			white
white			grey
grey			
step 30,8x61,5 cm 12"x24" <b>15,45/PZ</b>	gradino costa retta 30,8x61,5x4 cm 12"x24"x1 <sup>3/4</sup> " <b>83,33/PZ</b>	vista frontale angolare costa retta dx/sx 30,8x30,8x4 cm 12"x12"x1 <sup>3/4</sup> " <b>103,40/PZ</b>	battiscopa 6,5x61,5 cm 2 <sup>1/2</sup> "x24" <b>4,78/PZ</b>
sand	sand	sand	sand
brown	brown	brown	brown
white	white	white	white
grey	grey	grey	grey

Note - Notes - Notes - Anmerkungen

I battiscopa vengono venduti a pz. e a scatola completa. Tutti gli altri pezzi speciali vengono venduti al pezzo. I gradini vengono prodotti solo su ordinazione (tempo minimo di consegna 20 gg lavorativi).  
Skirtings are sold by piece and full boxes. All other special trims are sold by piece. Steps are produced only on request (minimum delivery terms of 20 days).  
Les plinthes sont vendues la pièce et par boîte complète. Les autres pièces spéciales sont vendues la pièce. Le plat de marche sont produit sur demande (délai minimum de 20 jours).  
Die Sockelleisten werden pro Stk. und Vollen Kartons verkauft. Stufen und Stufenecken werden nur auf Bestellung produziert (Lieferzeiten mindesten 20 arbeitstagen ab Auftragserteilung).

# BARK

---

*Grès porcellanato smaltato*  
*Glazed porcelain stoneware . Grès cérame émaillé . Glasiertes feinsteinzeug*

*effetto legno*  
*wood-look*  
*effet bois*  
*holzoptik*



*Legno a tutto campo per un'impressione visiva  
più compatta ed omogenea.  
Le leggerissime venature appena percettibili  
ne conferiscono una particolare eleganza e raffinatezza.*

*All-over wood for a visual impact  
that is more compact and homogeneous.  
The extremely fine grains that are hardly visible  
give this product a particularly elegant, sophisticated appearance.*

*Bois sur toute la superficie pour une impression visuelle  
plus compacte et homogène.  
Les très légères veinures à peine perceptibles  
lui apportent une élégance et un raffinement particuliers.*

*Rundum-Holz für einen kompakteren  
und homogeneren optischen Eindruck.  
Die sehr leichten, kaum wahrnehmbaren Adern verleihen ihm  
eine besondere Eleganz und Raffinesse.*

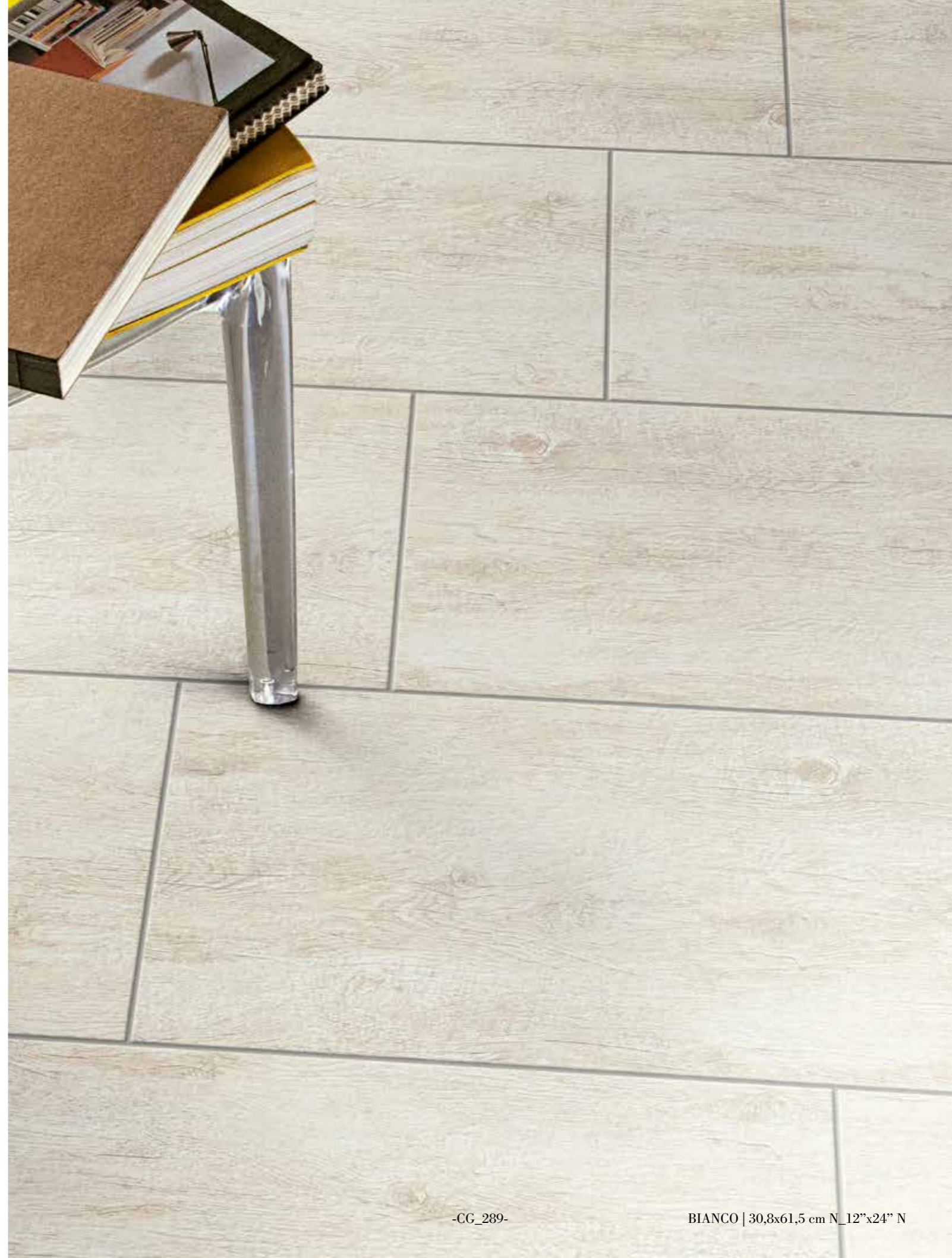

# BARK

Grès porcellanato smaltato  
Glazed porcelain stoneware  
Grès cérame émaillé  
Glasiertes Feinsteinzeug



**N** Naturale  
Natural



30,8x61,5 cm N . 12"x24" N

BARK  
Per la disponibilità articolo: [www.tuscaniagres.it](http://www.tuscaniagres.it)  
digitando il codice web segnalato a lato dei formati.  
For the item's availability: [www.tuscaniagres.it](http://www.tuscaniagres.it)  
type the web code reported next to the sizes.  
Pour vérifier la disponibilité de l'article: [www.tuscaniagres.it](http://www.tuscaniagres.it)  
en saisissant le code web indiqué à côté des formats.  
Für die Artikelverfügbarkeit: [www.tuscaniagres.it](http://www.tuscaniagres.it)  
web code eingeben, an der Seite von Formaten angedeutet.

bianco



H5F6 | 30,8x61,5 cm 12"x24" **N** 20,99

beige



H3N8 | 30,8x61,5 cm 12"x24" **N** 20,99

grigio



H6F0 | 30,8x61,5 cm 12"x24" **N** 20,99

noce



H3N7 | 30,8x61,5 cm 12"x24" **N** 20,99

pezzi speciali - special pieces - pièces spéciales - formteile

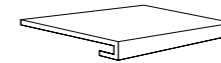

gradino costa retta  
30,8x61,5x4 cm 12"x24"x1 3/4"

**83,33/PZ**

bianco  
grigio  
beige  
noce

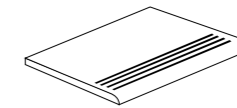

step  
30,8x61,5 cm N 12"x24" N

**15,45/PZ**

bianco  
grigio  
beige  
noce

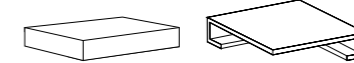

vista frontale  
angolare costa retta dx/sx  
30,8x30,8x4 cm N 12"x12"x1 3/4" N

vista dal retro  
**103,40/PZ**

bianco  
grigio  
beige  
noce



bianco  
grigio  
beige  
noce

battiscopa  
7,5x61,5 cm N 3"x24" N

**4,78/PZ**

bianco  
grigio  
beige  
noce

Note - Notes - Notes - Anmerkungen

I battiscopa vengono venduti a pz. e a scatola completa. Tutti gli altri pezzi speciali vengono venduti al pezzo. I gradini vengono prodotti solo su ordinazione (tempo minimo di consegna 20 gg lavorativi).  
Skirtings are sold by piece and full boxes. All other special trims are sold by piece. Steps are produced only on request (minimum delivery terms of 20 days).  
Les plinthes sont vendues la pièce et par boîte complète. Les autres pièces spéciales sont vendues la pièce. Le plat de marche sont produit sur demande (délai minimum de 20 jours).  
Die Sockelleisten werden pro Stk. und Vollen Kartons verkauft. Stufen und Stufenecken werden nur auf Bestellung produziert (Lieferzeiten mindesten 20 arbeitstagen ab Auftragserteilung).

# DHOGA

*Grès porcellanato impasto colorato*  
*Color body porcelain stoneware . Grès cérame coloré dans la masse . Durchgefärbtes Feinsteinzeug*

*effetto legno*  
*wood-look*  
*effet bois*  
*holzoptik*



*Una superficie screziata, graffiata e stonalizzata  
per realizzare un pattern decorativo dall'aspetto usurato,  
veramente nuovo ed inedito.*

*I colori si legano e trovano la loro completezza  
con una serie di stripe a tessera rettangolare  
per rendere la posa ancora più creativa.*

*With its streaked, scratched and faded surface  
it can be used to create a decorative layout with a used look  
that is truly new and original.*

*The colours blend together and are complemented  
by a series of stripes on rectangular tiles  
for an even more creative layout.*

*Une surface tachetée, éraflée et stonalisée  
Pour obtenir un pattern décoratif à l'aspect usé,  
vraiment nouveau et inédit.*

*Les couleurs se lient entre elles et trouvent leur complétude  
avec une série de bandes à carreaux rectangulaire  
pour rendre la pose encore plus créative.*

*Eine Oberfläche mit Flecken, Kratzern und Schattierungen,  
die ein dekoratives Muster mit einem abgenutzten,  
wirklich neuen und beispiellosen Aussehen entstehen lässt.  
Die Farben passen zueinander und werden durch eine Reihe  
von Streifen aus rechteckigen Mosaiksteinchen ergänzt,  
um die Verlegung noch kreativer zu gestalten.*



# DHOGA

Impasto Colorato  
Colored Body  
Masse Colorée  
Durchgefärbt



**N** Naturale Natural  
**R** Rettificato Rectified



30,8x61,5 cm N . 12"x24" N  
30,4x61,0 cm R . 12"x24" R

DHOGA  
Per la disponibilità articolo: [www.tuscaniagres.it](http://www.tuscaniagres.it)  
digitando il codice web segnalato a lato dei formati.  
For the item's availability: [www.tuscaniagres.it](http://www.tuscaniagres.it)  
type the web code reported next to the sizes.  
Pour vérifier la disponibilité de l'article: [www.tuscaniagres.it](http://www.tuscaniagres.it)  
en saisissant le code web indiqué à côté des formats.  
Für die Artikelverfügbarkeit: [www.tuscaniagres.it](http://www.tuscaniagres.it)  
web code eingeben, an der Seite von Formaten angedeutet.

decori - decors - décors - dekors

stripe monocolora 18 tessere 5x10 - 30x30 cm 12"x12" 13,27/PZ

bianco



H6D4 30,8x61,5 cm 12"x24" **N** 24,69  
H1H4 30,4x61,0 cm 12"x24" **R** 33,95

grigio



H5D2 30,8x61,5 cm 12"x24" **N** 24,69  
H1H5 30,4x61,0 cm 12"x24" **R** 33,95

bianco



grigio



nero

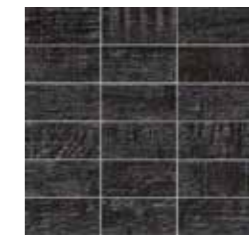

sabbia



sabbia



H8H2 30,8x61,5 cm 12"x24" **N** 24,69  
H9I5 30,4x61,0 cm 12"x24" **R** 33,95

nero



H7C4 30,8x61,5 cm 12"x24" **N** 24,69  
H1H6 30,4x61,0 cm 12"x24" **R** 33,95

pezzi speciali - special pieces - pièces spéciales - formteile

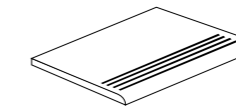

step  
30,8x61,5 cm 12"x24" 15,45/PZ

bianco  
grigio  
nero  
sabbia

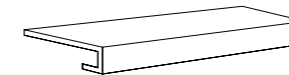

gradino costa retta  
30,8x61,5x4 cm 12"x24"x1 3/4" 83,33/PZ

bianco  
grigio  
nero  
sabbia

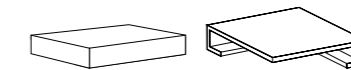

vista frontale vista dal retro  
angolare costa retta dx/sx  
30,8x30,8x4 cm 12"x12"x1 3/4" 103,40/PZ

bianco  
grigio  
nero  
sabbia



bianco



grigio



nero



sabbia

battiscopa 12  
7,5x61,5 cm 3"x24" 4,78/PZ

bianco  
grigio  
nero  
sabbia

Note - Notes - Notes - Anmerkungen

I battiscopa vengono venduti a pz. e a scatola completa. Tutti gli altri pezzi speciali vengono venduti al pezzo. I gradini vengono prodotti solo su ordinazione (tempo minimo di consegna 20 gg lavorativi).  
Skirtings are sold by piece and full boxes. All other special trims are sold by piece. Steps are produced only on request (minimum delivery terms of 20 days).  
Les plinthes sont vendues la pièce et par boîte complète. Les autres pièces spéciales sont vendus la pièce. Le plat de marche sont produit sur demande (délai minimum de 20 jours).  
Die Sockelleisten werden pro Stk. und Vollen Kartons verkauft. Stufen und Stufenecken werden nur auf Bestellung produziert (Lieferzeiten mindesten 20 arbeitstagen ab Auftragserteilung).

effetto cotto  
cotto-look . effet cotto . cottoptik



Camelot | 298  
Terre Toscane | 306

*Grès porcellanato*  
*Porcelain stoneware*  
*Grès cérame coloré*  
*Feinsteinzeug*

# CAMELOT

*Grès porcellanato smaltato*  
*Glazed porcelain stoneware . Grès cérame émaillé . Glasiertes feinsteinzeug*

*effetto cotto*  
*cotto-look*  
*effet cotto*  
*cottooptik*



*I primi splendidi pavimenti in terra cotta appartengono agli albori della lontana tradizione ceramica che ha trovato un terreno particolarmente fertile nel bacino dell' Europa mediterranea. Proprio dal cotto provenzale trova ispirazione questa linea di prodotti, realizzata in gres porcellanato con argille rare e pregiate che conferiscono agli ambienti una elevata bellezza di antico sapore.*

*The first magnificent floors in terracotta date back to the origins of ceramic tradition, which found a particularly fertile ground in Mediterranean Europe. This line of products is inspired by the terracotta from Provence, made in porcelain stoneware with rare, prized types of clay that will give any room particular elegance with antique appeal.*

*Les premiers splendides sols en terre cuite appartiennent aux prémices de la longue tradition céramique qui a trouvé un terrain particulièrement fertile dans le bassin de l'Europe méditerranéenne. C'est précisément le cotto provençal qui inspire cette ligne de produits, réalisée en grès cérame avec des argiles rares et précieux qui confèrent aux espaces une grande beauté à l'antique saveur.*

*Die ersten prächtigen Terrakotta-Böden verkörpern die Anfänge der fernen Keramik-Tradition, die im Mittelmeerraum einen besonders fruchtbaren Boden gefunden hat.*

*Diese Produktlinie ist von der provenzalischen Terrakotta inspiriert, die aus Feinsteinzeug mit seltenen und kostbaren Tönen hergestellt wird, die den Räumen ein schönes Gesamtbild mit rustikalen Optik verleihen.*





COTTO | 30,6x30,6 cm N/BM\_12"x12" N/BM  
15,1x30,6 cm N/BM\_6"x12" N/BM

-CG\_300-

CAMELOT

TRAMONTO | 15,1x30,6 cm N/BM outdoor\_6"x12" N/BM outdoor  
elemento "L" monolitico outdoor 15x30x4 cm\_6"x12"x1<sup>3/4</sup>"



-CG\_301-



# CAMELOT

Grès porcellanato smaltato  
Glazed porcelain stoneware  
Grès cérame émaillé  
Glasiertes Feinsteinzeug



**N/BM** Naturale/Bordo mosso  
Natural/Slight edges



30,6x30,6 cm N/BM .  
12"x12" N/BM



15,1x30,6 cm N/BM .  
6"x12" N/BM  
15,1x30,6 cm N/BM - outdoor .  
6"x12" N/BM - outdoor

Formati 30,6x30,6 e 15,1x30,6 prodotti con bordi irregolari e angoli arrotondati.  
30,6x30,6 and 15,1x30,6 sizes produced with uneven edges and rounded corners.  
Formats 30,6x30,6 et 15,1x30,6 produits avec bords irréguliers et angles arrondis.  
Format 30,6x30,6 und 15,1x30,6, mit unregelmäßigen Kanten und abgerundeten Ecken.

Materiale non esattamente calibrato; prevedere fuga di 5 mm.  
Calibration of this product is not exact; please considerer a 5 mm joint.  
Matériel non calibré de manière précise; prévoir un joint de 5 mm.  
Nicht exakt rektifiziertes Material, es muss eine Fuge von 5 mm vorgesehen werden.

Per la disponibilità articolo: [www.tuscaniagres.it](http://www.tuscaniagres.it)  
digitando il codice web segnalato a lato dei formati.  
For the item's availability: [www.tuscaniagres.it](http://www.tuscaniagres.it)  
type the web code reported next to the sizes.  
Pour vérifier la disponibilité de l'article: [www.tuscaniagres.it](http://www.tuscaniagres.it)  
en saisissant le code web indiqué à coté des formats.  
Für die Artikelverfügbarkeit: [www.tuscaniagres.it](http://www.tuscaniagres.it)  
web code eingeben, an der Seite von Formaten angedeutet.

beige



**J3E7** 30,6x30,6 cm 12"x12" **N/BM** 21,60

esempio di posa . laying compositions . exemple de pose . verlegemuster



tramonto



**J4E2** 30,6x30,6 cm 12"x12" **N/BM** 21,60

esempio di posa . laying compositions . exemple de pose . verlegemuster



**LOT2** 15,1x30,6 cm 6"x12" **N/BM** 24,07

**L7T3** 15,1x30,6 cm 6"x12" OUTDOOR **N/BM** 25,62

esempio di posa . laying compositions . exemple de pose . verlegemuster



**L7T4** 15,1x30,6 cm 6"x12" **N/BM** 24,07

**L7T5** 15,1x30,6 cm 6"x12" OUTDOOR **N/BM** 25,62

esempio di posa . laying compositions . exemple de pose . verlegemuster



# CAMELOT

Grès porcellanato smaltato  
Glazed porcelain stoneware  
Grès cérame émaillé  
Glasiertes Feinsteinzeug



Naturale/Bordo mosso  
Natural/Slight edges



30,6x30,6 cm N/BM  
12"x12" N/BM



15,1x30,6 cm N/BM  
6"x12" N/BM  
15,1x30,6 cm N/BM - outdoor  
6"x12" N/BM - outdoor

Formati 30,6x30,6 e 15,1x30,6 prodotti con bordi irregolari e angoli arrotondati.  
30,6x30,6 and 15,1x30,6 sizes produced with uneven edges and rounded corners.  
Formats 30,6x30,6 et 15,1x30,6 produits avec bords irréguliers et angles arrondis.  
Format 30,6x30,6 und 15,1x30,6, mit unregelmäßigen Kanten und abgerundeten Ecken.

Materiale non esattamente calibrato; prevedere fuga di 5 mm.  
Calibration of this product is not exact; please consider a 5 mm joint.  
Matériel non calibré de manière précise; prévoir un joint de 5 mm.  
Nicht exakt rektifiziertes Material, es muss eine Fuge von 5 mm vorgesehen werden.

## cotto



L9U1 | 30,6x30,6 cm 12"x12" | N/BM | 21,60

esempio di posa . laying compositions . exemple de pose . verlegemuster



L7T6 | 15,1x30,6 cm 6"x12" | N/BM | 24,07

L7T7 | 15,1x30,6 cm 6"x12" OUTDOOR | N/BM | 25,62

esempio di posa . laying compositions . exemple de pose . verlegemuster



## CAMELOT

Per la disponibilità articolo: [www.tuscaniagres.it](http://www.tuscaniagres.it)  
digitando il codice web segnalato a lato dei formati.  
For the item's availability: [www.tuscaniagres.it](http://www.tuscaniagres.it)  
type the web code reported next to the sizes.  
Pour vérifier la disponibilité de l'article: [www.tuscaniagres.it](http://www.tuscaniagres.it)  
en saisissant le code web indiqué à côté des formats.  
Für die Artikelverfügbarkeit: [www.tuscaniagres.it](http://www.tuscaniagres.it)  
web code eingeben, an der Seite von Formaten angedeutet.

BEIGE | 30,6x30,6 cm N/BM\_12"x12" N/BM - 15,1x30,6 cm N/BM outdoor\_6"x12" N/BM outdoor  
elemento "L" monolitico outdoor 15x30x4 cm\_6"x12"x1<sup>3/4</sup>"



decori - decors - décors - dekors

mosaico mix 36 tessere 5x5 13,27/PZ  
30x30 cm 12"x12"



cotto

battiscopa 36  
7,5x30,6 cm 3"x12"

2,31/PZ

beige

tramonto

cotto

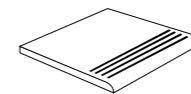

step  
30,6x30,6 cm N 12"x12" N

5,86/PZ

beige

tramonto

cotto

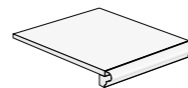

gradino con toro incollato  
30,6x30,6 cm N 12"x12" N

26,23/PZ

beige

tramonto

cotto

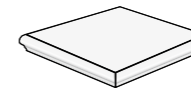

angolare con toro incollato  
30,6x30,6 cm N 12"x12" N

38,58/PZ

beige

tramonto

cotto

pezzi speciali - special pieces - pièces spéciales - formteile



beige

tramonto

cotto

elemento "L" monolitico outdoor  
15x30x4 cm 6"x12"x1<sup>3/4</sup>"

10,80/PZ

beige

tramonto

cotto

Note - Notes - Notes - Anmerkungen

I battiscopa vengono venduti a pz. e a scatola completa. Tutti gli altri pezzi speciali vengono venduti al pezzo. I gradini vengono prodotti solo su ordinazione (tempo minimo di consegna 20 gg lavorativi).  
Skirtings are sold by piece and full boxes. All other special trims are sold by piece. Steps are produced only on request (minimum delivery terms of 20 days).  
Les plinthes sont vendues la pièce et par boîte complète. Les autres pièces spéciales sont vendus la pièce. Le plat de marche sont produit sur demande (délai minimum de 20 jours).  
Die Sockelleisten werden pro Stk. und Vollen Kartons verkauft. Stufen und Stufenecken werden nur auf Bestellung produziert (Lieferzeiten mindesten 20 arbeitstagen ab Auftragserteilung).

# TERRE TOSCANE

*Grès porcellanato smaltato*  
*Glazed porcelain stoneware . Grès cérame émaillé . Glasiertes feinsteinzeug*

*effetto cotto*  
*cotto-look*  
*effet cotto*  
*cottooptik*



*La Toscana è la culla del Rinascimento.*  
*I paesi e le città sono patrimonio dell'Unesco, famose in tutto il mondo.*  
*I pavimenti di riferimento sono quelli, indistintamente,*  
*dei Casali contadini e delle nobili Residenze.*  
*“Terre Toscane” è il risultato di un attento studio perfettamente basato*  
*sulla storia dell'arredo architettonico di una regione unica nell'universo.*

*Tuscany is considered the cradle of the Renaissance movement.*  
*Its towns and cities are UNESCO world heritage sites, famous around the world.*  
*The reference pavements are those found, indistinctly,*  
*in the old peasant farmhouses and aristocratic mansions.*  
*"Terre Toscane" is the result of careful research based*  
*on the history of architectural design in a unique region in the universe.*

*La Toscane est le berceau de la Renaissance.*  
*Les villages et les villes sont inscrits au patrimoine de l'Unesco,*  
*renommés dans le monde entier.*  
*Les sols de référence sont ceux, indifféremment,*  
*des maisons paysannes et des demeures nobles.*  
*“Terre Toscane” est le résultat d'une étude approfondie qui s'appuie intégralement*  
*sur l'histoire du mobilier architectural d'une région unique dans l'univers.*

*Die Toskana ist die Wiege der Renaissance.*  
*Die Städte sind Unesco-Welterbestätten, die in der ganzen Welt bekannt*  
*sind. Solche Bodenbeläge findet man unterschiedslos in Bauernhäusern und*  
*Patrizierhäusern. „Terre Toscane“ ist das Ergebnis einer sorgfältigen Studie,*  
*die sich perfekt auf die Geschichte der architektonischen Gestaltung*  
*in dieser einzigartigen Region stützt.*





VOLTERRA | 15,1x30,6 cm N/BM outdoor\_6"x12" N/BM outdoor



# TERRE TOSCANE

Grès porcellanato smaltato  
Glazed porcelain stoneware  
Grès cérame émaillé  
Glasiertes Feinsteinzeug



outdoor

**N/BM** Naturale/Bordo mosso  
Natural/Slight edges

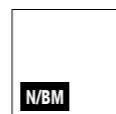

30,6x30,6 cm N/BM .  
12"x12" N/BM



15,1x30,6 cm N/BM .  
6"x12" N/BM  
15,1x30,6 cm N/BM - outdoor .  
6"x12" N/BM - outdoor

Formati 30,6x30,6 e 15,1x30,6 prodotti con bordi irregolari e angoli arrotondati.  
30,6x30,6 and 15,1x30,6 sizes produced with uneven edges and rounded corners.  
Formats 30,6x30,6 et 15,1x30,6 produits avec bords irréguliers et angles arrondis.  
Format 30,6x30,6 und 15,1x30,6, mit unregelmäßigen Kanten und abgerundeten Ecken.

Materiale non esattamente calibrato; prevedere fuga di 5 mm.  
Calibration of this product is not exact; please considerer a 5 mm joint.  
Matériel non calibré de manière précise; prévoir un joint de 5 mm.  
Nicht exakt rektifiziertes Material, es muss eine Fuge von 5 mm vorgesehen werden.

Per la disponibilità articolo: [www.tuscaniagres.it](http://www.tuscaniagres.it)  
digitando il codice web segnalato a lato dei formati.  
For the item's availability: [www.tuscaniagres.it](http://www.tuscaniagres.it)  
type the web code reported next to the sizes.  
Pour vérifier la disponibilité de l'article: [www.tuscaniagres.it](http://www.tuscaniagres.it)  
en saisissant le code web indiqué à coté des formats.  
Für die Artikelverfügbarkeit: [www.tuscaniagres.it](http://www.tuscaniagres.it)  
web code eingeben, an der Seite von Formaten angedeutet.

## san gimignano



**L5O4** | 30,6x30,6 cm 12"x12" **N/BM** | 21,60

esempio di posa . laying compositions . exemple de pose . verlegemuster



## volterra



**L5O1** | 30,6x30,6 cm 12"x12" **N/BM** | 21,60

esempio di posa . laying compositions . exemple de pose . verlegemuster



**L1P5** | 15,1x30,6 cm 6"x12" **N/BM** | 24,07

**L1P8** | 15,1x30,6 cm 6"x12" OUTDOOR **N/BM** | 25,62

esempio di posa . laying compositions . exemple de pose . verlegemuster



**I3S5** | 15,1x30,6 cm 6"x12" **N/BM** | 24,07

**L7T1** | 15,1x30,6 cm 6"x12" OUTDOOR **N/BM** | 25,62

esempio di posa . laying compositions . exemple de pose . verlegemuster



# TERRE TOSCANE

Grès porcellanato smaltato  
Glazed porcelain stoneware  
Grès cérame émaillé  
Glasiertes Feinsteinzeug



V4



outdoor

RANDOM

**N/BM** Naturale/Bordo mosso  
Natural/Slight edges

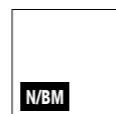

30,6x30,6 cm N/BM .  
12"x12" N/BM



15,1x30,6 cm N/BM .  
6"x12" N/BM  
15,1x30,6 cm N/BM - outdoor .  
6"x12" N/BM - outdoor

Formati 30,6x30,6 e 15,1x30,6 prodotti con bordi irregolari e angoli arrotondati.  
30,6x30,6 and 15,1x30,6 sizes produced with uneven edges and rounded corners.  
Formats 30,6x30,6 et 15,1x30,6 produits avec bords irréguliers et angles arrondis.  
Format 30,6x30,6 und 15,1x30,6, mit unregelmäßigen Kanten und abgerundeten Ecken.

Materiale non esattamente calibrato; prevedere fuga di 5 mm.  
Calibration of this product is not exact; please considerer a 5 mm joint.  
Matériel non calibré de manière précise; prévoir un joint de 5 mm.  
Nicht exakt rektifiziertes Material, es muss eine Fuge von 5 mm vorgesehen werden.

TERRE TOSCANE

Per la disponibilità articolo: [www.tuscaniagres.it](http://www.tuscaniagres.it)  
digitando il codice web segnalato a lato dei formati.  
For the item's availability: [www.tuscaniagres.it](http://www.tuscaniagres.it)  
type the web code reported next to the sizes.  
Pour vérifier la disponibilité de l'article: [www.tuscaniagres.it](http://www.tuscaniagres.it)  
en saisissant le code web indiqué à coté des formats.  
Für die Artikelverfügbarkeit: [www.tuscaniagres.it](http://www.tuscaniagres.it)  
web code eingeben, an der Seite von Formaten angedeutet.

vinci



**I0S3** | 30,6x30,6 cm 12"x12" **N/BM** | 21,60

esempio di posa . laying compositions . exemple de pose . verlegemuster



montalcino



**L5O2** | 30,6x30,6 cm 12"x12" **N/BM** | 21,60

esempio di posa . laying compositions . exemple de pose . verlegemuster



**L9U2** | 15,1x30,6 cm 6"x12" **N/BM** | 24,07

**L9U4** | 15,1x30,6 cm 6"x12" OUTDOOR **N/BM** | 25,62

esempio di posa . laying compositions . exemple de pose . verlegemuster



**I3S7** | 15,1x30,6 cm 6"x12" **N/BM** | 24,07

**I3S8** | 15,1x30,6 cm 6"x12" OUTDOOR **N/BM** | 25,62

esempio di posa . laying compositions . exemple de pose . verlegemuster



# TERRE TOSCANE

TERRE TOSCANE

decori - decors - décors - dekors

formella mix A (12 facce) - 30,6x30,6 cm 12"x12"



L907 | 30,6x30,6 cm 12"x12" 

N/BM 37,03/MQ

formella mix B (12 facce) - 30,6x30,6 cm 12"x12"



L906 | 30,6x30,6 cm 12"x12" 

N/BM 37,03/MQ

mosaico monocolor 36 tessere 5x5 - 30x30 cm 12"x12"  13,27/PZ

volterra



san gimignano

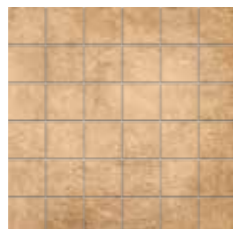

vinci



montalcino

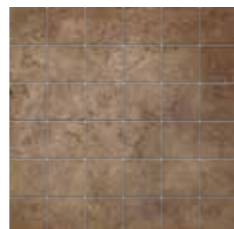

-CG\_316-

formella mix A | 30,6x30,6 cm N\_12"x12" N



pezzi speciali - special pieces - pièces spéciales - fornteile



battiscopa   
7,5x30,6 cm 3"x12"

2,31/PZ

volterra

san gimignano

vinci

montalcino

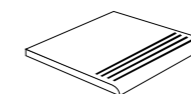

step  
30,6x30,6 cm N 12"x12" N

N 5,86/PZ

volterra

san gimignano

vinci

montalcino

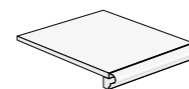

gradino con toro incollato  
30,6x30,6 cm N 12"x12" N

26,23/PZ

volterra

san gimignano

vinci

montalcino

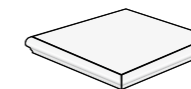

angolare con toro incollato  
30,6x30,6 cm N 12"x12" N

38,58/PZ

volterra

san gimignano

vinci

montalcino



elemento "L" monolitico outdoor  
15x30x4 cm 6"x12"x1 3/4"

10,80/PZ

volterra

san gimignano

vinci

montalcino

Note - Notes - Notes - Anmerkungen

I battiscopa vengono venduti a pz. e a scatola completa. Tutti gli altri pezzi speciali vengono venduti al pezzo. I gradini vengono prodotti solo su ordinazione (tempo minimo di consegna 20 gg lavorativi).  
Skirtings are sold by piece and full boxes. All other special trims are sold by piece. Steps are produced only on request (minimum delivery terms of 20 days).  
Les plinthes sont vendues la pièce et par boîte complète. Les autres pièces spéciales sont vendus la pièce. Le plat de marche sont produit sur demande (délai minimum de 20 jours).  
Die Sockelleisten werden pro Stk. und Vollen Kartons verkauft. Stufen und Stufenecken werden nur auf Bestellung produziert (Lieferzeiten mindesten 20 arbeitstagen ab Auftragserteilung).

-CG\_317-





# EASY COLLECTION

by tuscania

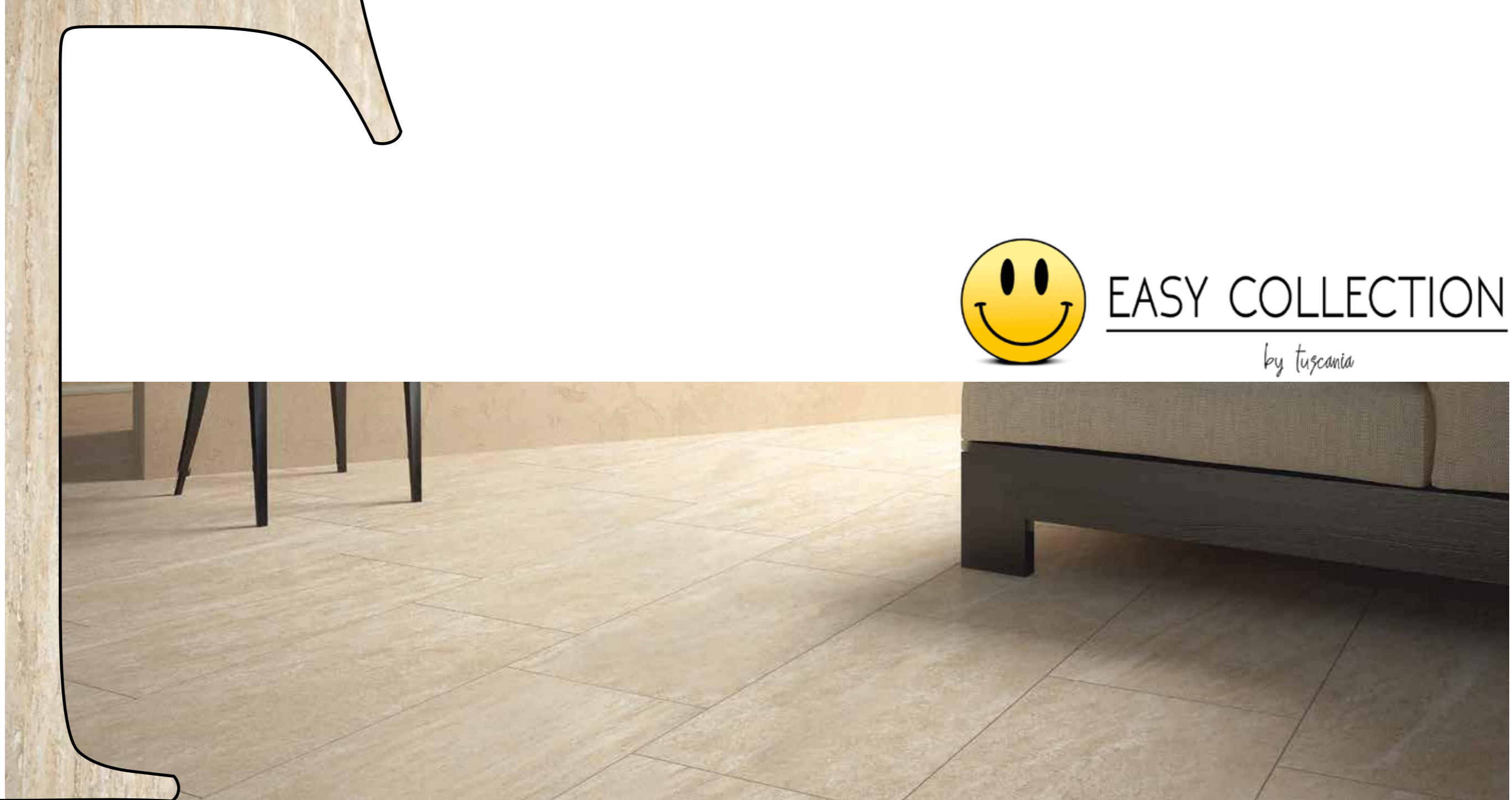

Beton floor easy collection	320
Cruz easy collection	328
Crystal easy collection	324
Modern easy collection	322
Trevi easy collection	326

*Grès porcellanato*  
*Porcelain stoneware*  
*Grès cérame coloré*  
*Feinsteinzeug*



# BETON



Grès porcellanato smaltato  
Glazed porcelain stoneware . Grès cérame émaillé . Glasiertes feinsteinzeug

effetto cemento  
concrete-look  
effet ciment  
zementoptik



pezzi speciali - special pieces - pièces spéciales - formteile



decori - decors - décors - dekors

mosaico mix 36 tessere 5x5 -  
30x30 cm 12"x12"



Note - Notes - Notes - Anmerkungen

I battiscopa vengono venduti a pz. e a scatola completa. Tutti gli altri pezzi speciali vengono venduti al pezzo. I gradini vengono prodotti solo su ordinazione (tempo minimo di consegna 20 gg lavorativi).  
Skirtings are sold by piece and full boxes. All other special trims are sold by piece. Steps are produced only on request (minimum delivery terms of 20 days).  
Les plinthes sont vendues la pièce et par boîte complète. Les autres pièces spéciales sont vendus la pièce. Le plat de marche sont produit sur demande (délai minimum de 20 jours).  
Die Sockelleisten werden pro Stk. und Vollen Kartons verkauft. Stufen und Stufenecken werden nur auf Bestellung produziert (Lieferzeiten mindesten 20 arbeitstagen ab Auftragserteilung).



rivestimento coordinato - matching wall tiles -  
faïences coordonnées - koordinierte wandfliesen:  
**BETON easy collection 20x50 cm 8"x20"**  
Bicottura tradizionale . Traditional double fired .  
Traditionelle double feu . Zweibrandfliesen - pag. 390

# BETON

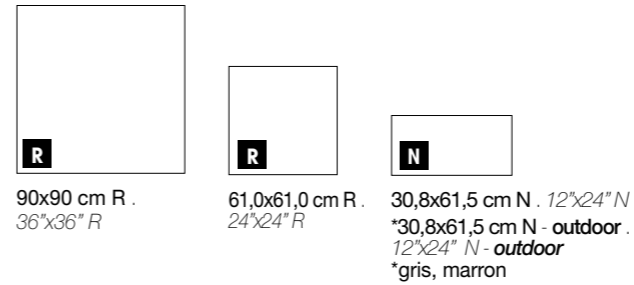

Per la disponibilità articolo: [www.tuscaniagres.it](http://www.tuscaniagres.it) digitando il codice web segnalato a lato dei formati.  
For the item's availability: [www.tuscaniagres.it](http://www.tuscaniagres.it) type the web code reported next to the sizes.  
Pour vérifier la disponibilité de l'article: [www.tuscaniagres.it](http://www.tuscaniagres.it) en saisissant le code web indiqué à coté des formats.  
Für die Artikelverfügbarkeit: [www.tuscaniagres.it](http://www.tuscaniagres.it) web code eingeben, an der Seite von Formaten angedeutet.

Grès porcellanato smaltato  
Glazed porcelain stoneware  
Grès cérame émaillé  
Glasiertes feinsteinzeug

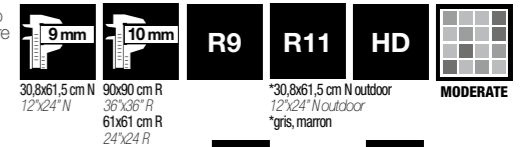

blanc



L4V0	90x90 cm 36"x36"	R
L2V6	61,0x61,0 cm 24"x24"	R
L1N8	30,8x61,5 cm 12"x24"	N

taupe



L3V3	90x90 cm 36"x36"	R
L2V7	61,0x61,0 cm 24"x24"	R
L1N7	30,8x61,5 cm 12"x24"	N

gris



L3V2	90x90 cm 36"x36"	R
L2V8	61,0x61,0 cm 24"x24"	R
L1N6	30,8x61,5 cm 12"x24"	N
L9R5	30,8x61,5 cm 12"x24" OUTDOOR	N

marron



L3V1	90x90 cm 36"x36"	R
L2V9	61,0x61,0 cm 24"x24"	R
L1N5	30,8x61,5 cm 12"x24"	N
L9R6	30,8x61,5 cm 12"x24" OUTDOOR	N

# MODERN



Grès porcellanato impasto colorato  
Color body porcelain stoneware . Grès cérame coloré dans la masse . Durchgefärbtes Feinsteinzeug

effetto cemento  
concrete-look  
effet ciment  
zementoptik



pezzi speciali - special pieces - pièces spéciales - formteile

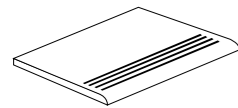

step **N**  
30,8x61,5 cm N 12"x24" N  
45,5x45,5 cm N 18"x18" N

beige  
grey  
black

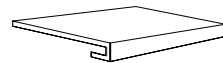

gradino costa retta  
34x61,0x4 cm 13"x24"x1<sup>3/4</sup>"  
34x45,5x4 cm 13"x18"x1<sup>3/4</sup>"

beige  
grey  
black



vista frontale  
angolare costa retta dx/sx  
34x34x4 cm 13"x13" x1<sup>3/4</sup>"  
34x34x4 cm 13"x13"x1<sup>3/4</sup>"

beige  
grey  
black

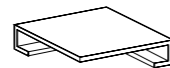

vista dal retro

beige  
grey  
black



beige  
grey  
black  
battiscopa   
7,5x45,5 cm N 3"x18" N **N**  
beige  
grey  
black

Note - Notes - Notes - Anmerkungen

I battiscopa vengono venduti a pz. e a scatola completa. Tutti gli altri pezzi speciali vengono venduti al pezzo. I gradini vengono prodotti solo su ordinazione (tempo di consegna 20 gg lavorativi).  
Skirtings are sold by piece and full boxes. All other special trims are sold by piece. Steps are produced only on request (minimum delivery terms of 20 days).  
Les plinthes sont vendues la pièce et par boîte complète. Les autres pièces spéciales sont vendues la pièce. Le plat de marche sont produit sur demande (délai minimum de 20 jours).  
Die Sockelleisten werden pro Stk. und Vollen Kartons verkauft. Stufen und Stufenecken werden nur auf Bestellung produziert (Lieferzeiten mindesten 20 arbeitstagen ab Auftragserteilung).

# MODERN

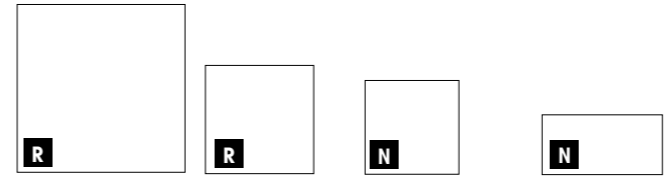

90x90 cm R . 36"x36" R  
61,0x61,0 cm R . 24"x24" R  
45,5x45,5 cm N . 18"x18" N  
30,8x61,5 cm N . 12"x24" N

**N** Naturale  
Natural

**R** Rettificato  
Rectified

45,5x45,5 cm N 18"x18" N  
30,8x61,5 cm N 12"x24" N  
90x90 cm R 36"x36" R  
61x61 cm R 24"x24" R

Impasto Colorato  
Colored Body  
Masse Colorée  
Durchgefärbt

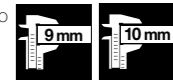

LOW



Per la disponibilità articolo: [www.tuscaniagres.it](http://www.tuscaniagres.it) digitando il codice web segnalato a lato dei formati.  
For the item's availability: [www.tuscaniagres.it](http://www.tuscaniagres.it) type the web code reported next to the sizes.  
Pour vérifier la disponibilité de l'article: [www.tuscaniagres.it](http://www.tuscaniagres.it) en saisissant le code web indiqué à coté des formats.  
Für die Artikelverfügbarkeit: [www.tuscaniagres.it](http://www.tuscaniagres.it) web code eingeben, an der Seite von Formaten angedeutet.

grey



L3V4	90x90 cm 36"x36"	<b>R</b>
L4V0	61,0x61,0 cm 24"x24"	<b>R</b>
H4H6	45,5x45,5 cm 18"x18"	<b>N</b>
H4H8	30,8x61,5 cm 12"x24"	<b>N</b>

black



L3V5	90x90 cm 36"x36"	<b>R</b>
L4V1	61,0x61,0 cm 24"x24"	<b>R</b>
H4H7	45,5x45,5 cm 18"x18"	<b>N</b>
H4H9	30,8x61,5 cm 12"x24"	<b>N</b>

beige

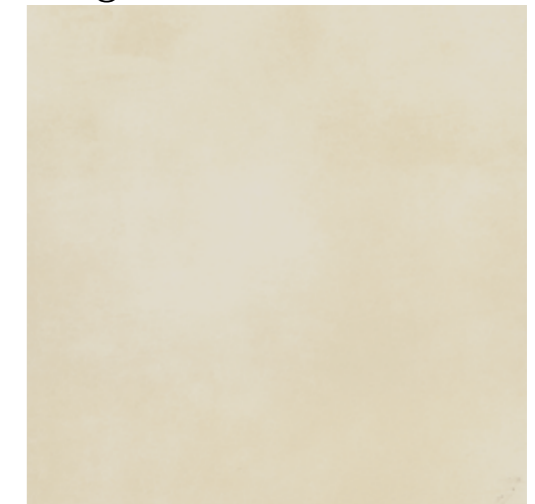

L3V7	90x90 cm 36"x36"	<b>R</b>
L4V3	61,0x61,0 cm 24"x24"	<b>R</b>
L4V5	45,5x45,5 cm 18"x18"	<b>N</b>
L3V9	30,8x61,5 cm 12"x24"	<b>N</b>



Regardez sur le site internet [www.cstb.fr](http://www.cstb.fr) s'il vous plaît

# CRYSTAL



*Grès porcellanato smaltato*  
*Glazed porcelain stoneware . Grès cérame émaillé . Glasiertes feinsteinzeug*

*effetto marmo*  
*marble-look*  
*effet marbre*  
*marmoroptik*



BEIGE | 45,5x45,5 cm R\_18"x18" R



# CRYSTAL

Grès porcellanato smaltato  
 Glazed porcelain stoneware  
 Grès cérame émaillé  
 Glasiertes feinsteinzeug



45,5x45,5 cm N . 18"x18" N

Per la disponibilità articolo: [www.tuscaniagres.it](http://www.tuscaniagres.it) digitando il codice web segnalato a lato dei formati.  
 For the item's availability: [www.tuscaniagres.it](http://www.tuscaniagres.it) type the web code reported next to the sizes.  
 Pour vérifier la disponibilité de l'article: [www.tuscaniagres.it](http://www.tuscaniagres.it) en saisissant le code web indiqué à coté des formats.  
 Für die Artikelverfügbarkeit: [www.tuscaniagres.it](http://www.tuscaniagres.it) web code eingeben, an der Seite von Formaten angedeutet.



## beige



H5C1 | 45,5x45,5 cm 18"x18" **N**

## grigio



H4I5 | 45,5x45,5 cm 18"x18" **N**

pezzi speciali - special pieces - pièces spéciales - formteile

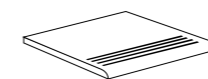

step  
 45,5x45,5 cm N 18"x18" N **N**  
 grigio  
 beige

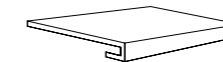

gradino costa retta  
 34x45,5x4 cm 13"x18"x1 3/4"  
 grigio  
 beige

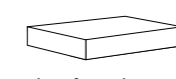

vista frontale  
 angolare costa retta dx/sx  
 34x34x4 cm 13"x13"x1 3/4"  
 grigio  
 beige



vista dal retro  
 grigio  
 beige



grigio



beige

battiscopa   
 7,5x45,5 cm N 3"x18" N **N**  
 grigio  
 beige

Note - Notes - Notes - Anmerkungen

I battiscopa vengono venduti a pz. e a scatola completa. Tutti gli altri pezzi speciali vengono venduti al pezzo. I gradini vengono prodotti solo su ordinazione (tempo di consegna 20 gg lavorativi).  
 Skirtings are sold by piece and full boxes. All other special trims are sold by piece. Steps are produced only on request (minimum delivery terms of 20 days).  
 Les plinthes sont vendues la pièce et par boîte complète. Les autres pièces spéciales sont vendues la pièce. Le plat de marche sont produit sur demande (délai minimum de 20 jours).  
 Die Sockelleisten werden pro Stk. und Vollen Kartons verkauft. Stufen und Stufenecken werden nur auf Bestellung produziert (Lieferzeiten mindesten 20 arbeitstagen ab Auftragserteilung).

# TREVI



*Grès porcellanato smaltato*  
*Glazed porcelain stoneware . Grès cérame émaillé . Glasiertes feinsteinzeug*

*effetto pietra*  
*stone-look*  
*effet pierre*  
*steinoptik*



# TREVI

Grès porcellanato smaltato  
 Glazed porcelain stoneware  
 Grès cérame émaillé  
 Glasiertes feinsteinzeug



30,8x61,5 cm N . 12"x24" N

Per la disponibilità articolo: [www.tuscaniagres.it](http://www.tuscaniagres.it) digitando il codice web segnalato a lato dei formati.  
 For the item's availability: [www.tuscaniagres.it](http://www.tuscaniagres.it) type the web code reported next to the sizes.  
 Pour vérifier la disponibilité de l'article: [www.tuscaniagres.it](http://www.tuscaniagres.it) en saisissant le code web indiqué à coté des formats.  
 Für die Artikelverfügbarkeit: [www.tuscaniagres.it](http://www.tuscaniagres.it) web code eingeben, an der Seite von Formaten angedeutet.

**N** Naturale  
 Natural

almond



H9E7 | 30,8x61,5 cm 12"x24" **N**

beige



H9E6 | 30,8x61,5 cm 12"x24" **N**

BEIGE | 30,8x61,5 cm N\_12"x24" N



pezzi speciali - special pieces - pièces spéciales - formteile

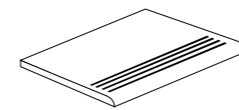

step  
 30,8x61,5 cm N 12"x24" N

almond  
 beige

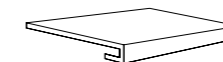

gradino costa retta  
 30,8x61,5x4 cm 12"x24"x1 3/4"

almond  
 beige



vista frontale  
 angolare costa retta dx/sx  
 30,8x30,8x4 cm N 12"x12"x1 3/4" N

almond  
 beige



vista dal retro

almond  
 beige



almond

beige

battiscopa 7,5x61,5 cm N 3"x24" N **N**

almond  
 beige

Note - Notes - Notes - Anmerkungen

I battiscopa vengono venduti a pz. e a scatola completa. Tutti gli altri pezzi speciali vengono venduti al pezzo. I gradini vengono prodotti solo su ordinazione (tempo di consegna 20 gg lavorativi).  
 Skirtings are sold by piece and full boxes. All other special trims are sold by piece. Steps are produced only on request (minimum delivery terms of 20 days).  
 Les plinthes sont vendues la pièce et par boîte complète. Les autres pièces spéciales sont vendues la pièce. Le plat de marche sont produit sur demande (délai minimum de 20 jours).  
 Die Sockelleisten werden pro Stk. und Vollen Kartons verkauft. Stufen und Stufencken werden nur auf Bestellung produziert (Lieferzeiten mindesten 20 arbeitstagen ab Auftragserteilung).

# CRUZ



*Grès porcellanato smaltato*  
*Glazed porcelain stoneware . Grès cérame émaillé . Glasiertes feinsteinzeug*

*effetto legno*  
*wood-look*  
*effet bois*  
*holzoptik*



pezzi speciali - special pieces - pièces spéciales - formteile



crema



beige



grigio

**battiscopa**  
 7,5x61,5 cm 3"x24"

crema  
 beige  
 grigio

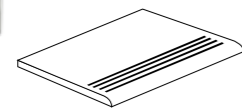

**step**  
 30,8x61,5 cm 12"x24"

crema  
 beige  
 grigio

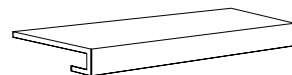

**gradino costa retta**  
 30,8x61,5x4 cm 12"x24"x1 3/4"

crema  
 beige  
 grigio

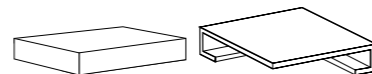

**vista frontale**  
**angolare costa retta dx/sx**  
 30,8x30,8x4 cm 12"x12"x1 3/4"

crema  
 beige  
 grigio

Note - Notes - Notes - Anmerkungen

I battiscopa vengono venduti a pz. e a scatola completa. Tutti gli altri pezzi speciali vengono venduti al pezzo. I gradini vengono prodotti solo su ordinazione (tempo minimo di consegna 20 gg lavorativi).  
 Skirtings are sold by piece and full boxes. All other special trims are sold by piece. Steps are produced only on request (minimum delivery terms of 20 days).  
 Les plinthes sont vendues la pièce et par boîte complète. Les autres pièces spéciales sont vendues la pièce. Le plat de marche sont produit sur demande (délai minimum de 20 jours).  
 Die Sockelleisten werden pro Stk. und Vollen Kartons verkauft. Stufen und Stufenecken werden nur auf Bestellung produziert (Lieferzeiten mindesten 20 arbeitstagen ab Auftragserteilung).

# CRUZ

Grès porcellanato smaltato  
 Glazed porcelain stoneware  
 Grès cérame émaillé  
 Glasiertes feinsteinzeug



N

30,8x61,5 cm N . 12"x24" N

Per la disponibilità articolo: [www.tuscaniagres.it](http://www.tuscaniagres.it) digitando il codice web segnalato a lato dei formati.  
 For the item's availability: [www.tuscaniagres.it](http://www.tuscaniagres.it) type the web code reported next to the sizes.  
 Pour vérifier la disponibilité de l'article: [www.tuscaniagres.it](http://www.tuscaniagres.it) en saisissant le code web indiqué à coté des formats.  
 Für die Artikelverfügbarkeit: [www.tuscaniagres.it](http://www.tuscaniagres.it) web code eingeben, an der Seite von Formaten angedeutet.

N

Naturale  
 Natural

crema



L4N6 | 30,8x61,5 cm 12"x24"

N

grigio



L4N5 | 30,8x61,5 cm 12"x24"

N

beige



L4N7 | 30,8x61,5 cm 12"x24"

N

decori - decors - décors - dekors

mosaico mix dritto/rovescio

36 tessere 5x5 - 30x30 cm 12"x12"

beige/crema

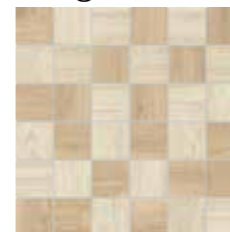

mosaico monocolore dritto/rovescio

36 tessere 5x5 - 30x30 cm 12"x12"

grigio

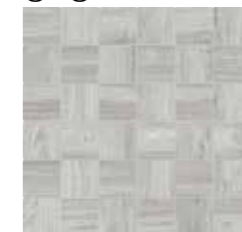

# technical project

## Pregio e sicurezza

*Le possibilità applicative del grès porcellanato per pavimentazioni in spazi interni ed esterni sono vastissime e destinate a superfici alternative, sia di uso pubblico che privato. Materia pregiata con caratteristiche tecniche e prestazionali impareggiabili.*

## High quality and safety

*Porcelain tiles offer a huge range of different possibilities for indoor and outdoor finishings intended for both private and public areas. Fine-quality material with unique technical and well-performing features.*

## Qualité et sécurité

*Les possibilités d'application du grès cérame pour les sols d'intérieur et extérieur sont innombrables et destinées à des surfaces alternatives, aussi bien dans le secteur public que privé. Une matière de grande qualité possédant des caractéristiques techniques et uniques.*

## Prestige und Sicherheit

*Es gibt zahlreiche Einsatzmöglichkeiten für Feinsteinzeug als Fußboden in Innen- und Außenbereichen für alternative Anwendungen, in öffentlichen und privaten Oberflächen. Ein kostbares mit unvergleichbaren technischen Merkmalen und Leistungen.*



Spessore  
Thickness  
Épaisseur  
Stärke  
2 cm



336

Atelier FP2	338	Meteora FP2	348
Cor-Stone FP2	354	My S'tile FP2	340
Decapé FP2	364	North Wind FP2	368
Durango FP2	356	Pierre Bleue FP2	352
Edelweiss FP2	358	Sparkly FP2	362
Fjord FP2	366	Technika FP2	344
Grey Soul FP2	346	Terraforte FP2	360
Limestone FP2	342	Thunderwood FP2	370

Industrial	332
Rall	334

*Grès porcellanato  
Porcelain stoneware  
Grès cérame coloré  
Feinsteinzeug*

**T**  
**TUSCANIA**  
ceramiche

# INDUSTRIAL

*Grès porcellanato tutta massa*  
*Full body porcelain stoneware . Grès cérame coloré dans la masse . Durchgefärbtes Feinsteinzeug*

## technical project



indoor: GRIGIO | 20x20 cm N\_8"x8" N - outdoor: 20x20 cm NS\_8"x8" NS



# INDUSTRIAL

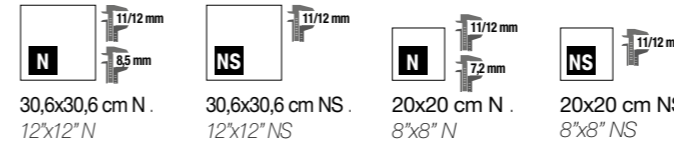

Per la disponibilità articolo: [www.tuscaniagres.it](http://www.tuscaniagres.it) digitando il codice web segnalato a lato dei formati.  
 For the item's availability: [www.tuscaniagres.it](http://www.tuscaniagres.it) type the web code reported next to the sizes.  
 Pour vérifier la disponibilité de l'article: [www.tuscaniagres.it](http://www.tuscaniagres.it) en saisissant le code web indiqué à coté des formats.  
 Für die Artikelverfügbarkeit: [www.tuscaniagres.it](http://www.tuscaniagres.it) web code eingeben, an der Seite von Formaten angedeutet.

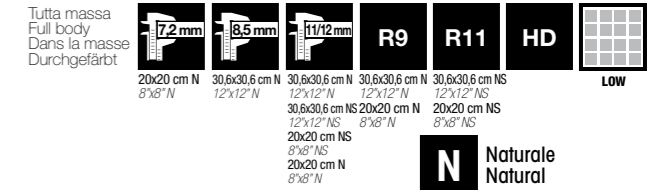

## panna

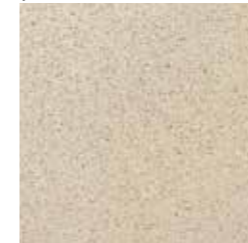

J3V1	30,6x30,6 cm 12"x12"		<b>N</b>	19,10
L9Q9	30,6x30,6 cm 12"x12"		<b>N</b>	24,69
L9Q4	30,6x30,6 cm 12"x12"		<b>NS</b>	25,62
J9P8	20x20 cm 8"x8"		<b>N</b>	16,98
J4R5	20x20 cm 8"x8"		<b>N</b>	24,69
L0R2	20x20 cm 8"x8"		<b>NS</b>	25,62

## beige

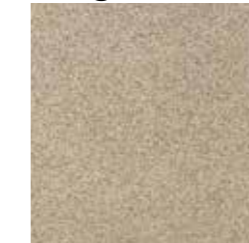

J2V9	30,6x30,6 cm 12"x12"		<b>N</b>	19,10
L9Q7	30,6x30,6 cm 12"x12"		<b>N</b>	24,69
L1V9	30,6x30,6 cm 12"x12"		<b>NS</b>	25,62
J3R9	20x20 cm 8"x8"		<b>N</b>	16,98
J4R1	20x20 cm 8"x8"		<b>N</b>	24,69
L0R1	20x20 cm 8"x8"		<b>NS</b>	25,62

## grigio



J3V0	30,6x30,6 cm 12"x12"		<b>N</b>	19,10
L0R0	30,6x30,6 cm 12"x12"		<b>N</b>	24,69
L2V1	30,6x30,6 cm 12"x12"		<b>NS</b>	25,62
J3L8	20x20 cm 8"x8"		<b>N</b>	16,98
J9P9	20x20 cm 8"x8"		<b>N</b>	24,69
L0R3	20x20 cm 8"x8"		<b>NS</b>	25,62

GRIGIO | 20x20 cm NS\_8"x8" NS



pezzi speciali - special pieces - pièces spéciales - formteile



battiscopa	7,5x30,6 cm N 3"x12" N		<b>N</b>	2,31/PZ
	6,5x20 cm N 2 1/2"x8" N		<b>N</b>	2,31/PZ
panna				
beige				
grigio				

Note - Notes - Notes - Anmerkungen  
 I battiscopa vengono venduti a pz. e a scatola completa. - Skirtings are sold by piece and full boxes.  
 Les plinthes sont vendues la pièce et par boîte complète. - Die Sockelleisten werden pro Stk. und Vollen Kartons verkauft.



# RALL

*Grès porcellanato smaltato*  
*Glazed porcelain stoneware . Grès cérame émaillé . Glasiertes feinsteinzeug*

## technical project

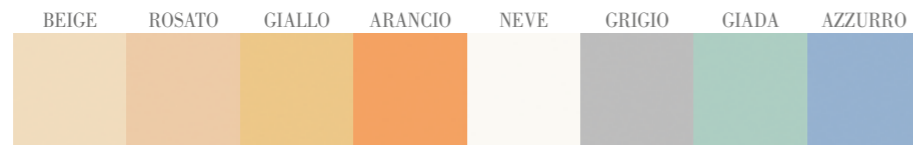

*Colori in tinta unita vivi, luminosi e solari  
 regalano alla casa una nuova dimensione.*

*Si aprono spazi sempre più ampi ed universali  
 dove creatività e funzionalità si incontrano.*

*Cadono i confini normali della bellezza e si aprono nuove prospettive.*

*Bright, luminous and sunny plain colours  
 to bring a new dimension to the home.*

*Increasingly wide, universal spaces are opened,  
 blending creativity and functionality.*

*The normal boundaries of beauty are broken down to offer new perspectives.*

*Des couleurs unies intenses, lumineuses et solaires offrent à la maison une  
 dimension nouvelle. Des espaces de plus en plus vastes et universels,  
 où la créativité et la fonctionnalité voient le jour.*

*Les frontières habituelles de la beauté sont abolies et  
 de nouvelles perspectives s'ouvrent.*

*Lebendige, leuchtende und sonnige Uni-Farben geben dem Zuhause eine neue  
 Dimension. Die Räume werden größer und universeller und Kreativität und  
 Funktionalität verbinden sich. Die gewohnten Grenzen der Schönheit  
 fallen und neue Perspektiven eröffnen sich.*

# RALL



20x20 cm N . 8"x8" N

Grès porcellanato smaltato  
 Glazed porcelain stoneware  
 Grès cérame émaillé  
 Glasiertes feinsteinzeug



V1



LOW



Naturale  
 Natural

Per la disponibilità articolo: [www.tuscaniagres.it](http://www.tuscaniagres.it) digitando il codice web segnalato a lato dei formati.  
 For the item's availability: [www.tuscaniagres.it](http://www.tuscaniagres.it) type the web code reported next to the sizes.  
 Pour vérifier la disponibilité de l'article: [www.tuscaniagres.it](http://www.tuscaniagres.it) en saisissant le code web indiqué à coté des formats.  
 Für die Artikelverfügbarkeit: [www.tuscaniagres.it](http://www.tuscaniagres.it) web code eingeben, an der Seite von Formaten angedeutet.

beige



L4V6 | 20x20 cm 8"x8" N | 24,07

rosato



L4V7 | 20x20 cm 8"x8" N | 24,07

giallo



L4V8 | 20x20 cm 8"x8" N | 24,07

arancio



L4V9 | 20x20 cm 8"x8" N | 24,07

neve

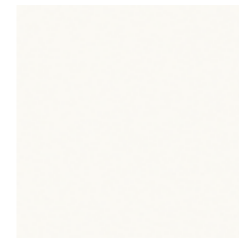

L5V0 | 20x20 cm 8"x8" N | 24,07

grigio



L5V1 | 20x20 cm 8"x8" N | 24,07

giada



L5V2 | 20x20 cm 8"x8" N | 24,07

azzurro



L5V3 | 20x20 cm 8"x8" N | 24,07

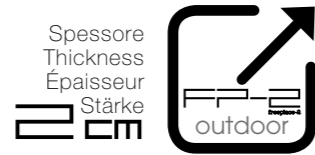

*technical project*

- Posa sopraelevata**  
Raised installation  
Pose surélevée  
Verlegung als Doppelboden
- Posa a secco su erba**  
Dry laying on grass  
Pose à sec en appui sur pelouse  
Trockenverlegung auf Gras
- Posa a secco su ghiaia**  
Dry laying on gravel  
Pose à sec sur gravier  
Trockenverlegung auf Kies
- Posa su massetto con colla**  
Laying on screed with adhesive  
Pose sur chape avec de la colle  
Verlegung auf Estrich mit Kleber
- Posa a secco su sabbia**  
Dry laying on sand  
Pose à sec sur sable  
Trockenverlegung auf Sand



Materia pregiata e spessorata (2 cm) con caratteristiche tecniche e prestazionali impareggiabili.  
Un progetto esclusivo ed ambizioso, tecnologicamente avanzato.  
Ideale per applicazioni outdoor.  
Eccezionale per applicazioni a secco su erba, ghiaia, massetto, sabbia e posa sopraelevata.  
Pratico e facile da posare.  
Fruibile in tempo reale.

Une matière de grande qualité et l'épaisseur majorée (2 cm) possédant des caractéristiques techniques et performancielles sans pareilles.  
Un projet exclusif et ambitieux, à la pointe de la technologie. Idéal pour des applications à l'extérieur. Exceptionnel pour des applications à sec en appui sur pelouse, gravier, chape, sable et pose surélevée.  
Pratique et facile à poser.  
Piétinable immédiatement après la pose.

Fine-quality and thickened (2 cm) material with unrivalled technical characteristics and performances.  
An exclusive, ambitious, technologically advanced project.  
Ideal for outdoor applications.  
Exceptional for dry applications on grass, gravel, slabs, sand and raised installation.  
Practical and easy to lay. Ready to use.

Ein kostbares und extra starkes Material mit unvergleichbaren technischen Merkmalen und Leistungen.  
Ein exklusives fortgeschrittenes Projekt. Ideal für Outdoor-Anwendungen.  
Bestens für die trockene Verlegung auf Gras, Kies, Estrich, Sand und als Doppelboden geeignet.  
Praktisch und einfach zu verlegen.  
In Echtzeit nutzbar.

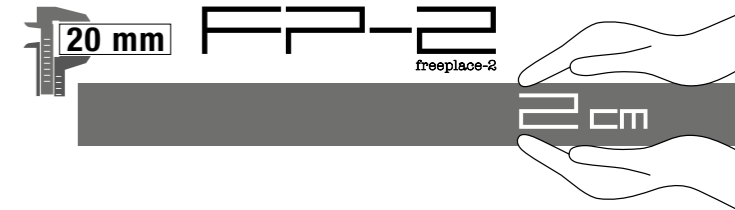

Tipologia di supporti per la posa sopraelevata  
Type of supports for raised floor laying  
Typologie de supports pour la pose surélevée  
Trägerart für die Verlegung als Doppelboden



**Supporto fisso** . Fixed support  
Support fixe . Fester Träger

**Supporto regolabile** . Adjustable support  
Support réglable . Höhenverstellbarer Träger

**Supporto autolivellante** . Self-levelling support  
Support auto-nivelant . Selbstnivellierender Träger

Esempi di posa . Laying scheme examples . Exemples de pose . Verlegebeispiele

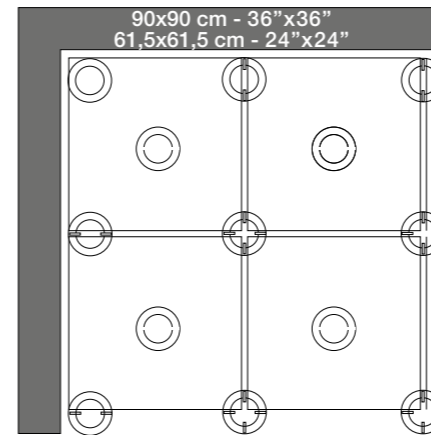

**Supporti regolabili e supporti autolivellanti**  
Adjustable supports and self-leveling supports  
Supports réglables et supports auto-nivelants  
Höhenverstellbarer Träger und Selbstnivellierender Träger

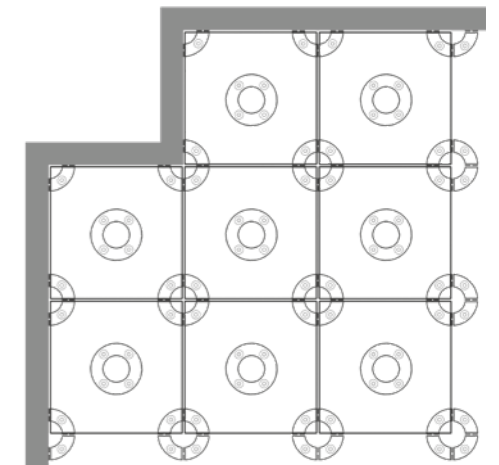
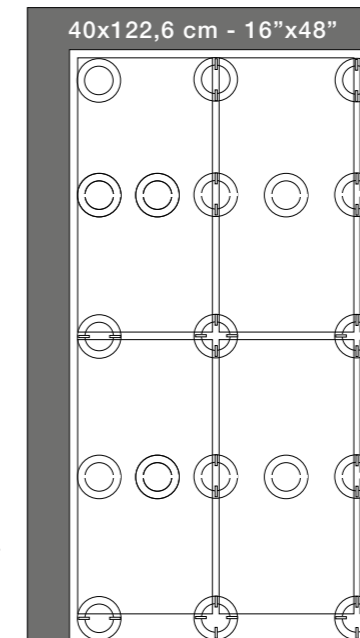

**Supporti fissi**  
Fixed supports - Support fixe - Fester Träger

**Suggerimenti per la posa flottante**

Raccomandiamo l'uso di un supporto centrale alla lastra al fine di distribuire in modo omogeneo i carichi.

**Conseils pour la pose flottante**

Nous recommandons l'utilisation d'un support central sous la dalle afin de répartir uniformément les charges.

**Tips for floating installation**

We recommend the use of a central slab support in order to distribute the loads equally.

**Empfehlungen für die schwimmende verlegung**

Wir empfehlen die Verwendung von in der Mitte anzubringenden Stützen, damit die Belastung gleichmäßig verteilt wird.

SUPPORTI SUPPORTS SUPPORT TRÄGER	ALTEZZA HEIGHT HAUTEUR HÖHE
SUPPORTO FISSO FIXED SUPPORT SUPPORT FIXE FESTER TRÄGER	15 mm
SUPPORTO REGOLABILE ADJUSTABLE SUPPORT SUPPORT RÉGLABLE HÖHENVERSTELLBARER TRÄGER	25 - 40 mm
SUPPORTO AUTOLIVELLANTE SELF-LEVELLING SUPPORT SUPPORT AUTO-NIVELANT SELBSTNIVELLIERENDER TRÄGER	37,5 - 50 mm

# ATELIER

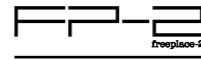

Grès porcellanato impasto colorato  
Color body porcelain stoneware . Grès cérame coloré dans la masse . Durchgefärbtes feinsteinzeug



technical project



GRIS FP2 | 90x90 cm RS\_36"x36" RS



# FP2 ATELIER

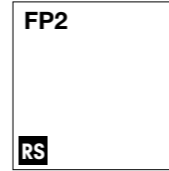

90x90 cm RS . 36"x36" RS

Per la disponibilità articolo: [www.tuscaniagres.it](http://www.tuscaniagres.it)  
digitando il codice web segnalato a lato dei formati.  
For the item's availability: [www.tuscaniagres.it](http://www.tuscaniagres.it)  
type the web code reported next to the sizes.  
Pour vérifier la disponibilité de l'article: [www.tuscaniagres.it](http://www.tuscaniagres.it)  
en saisissant le code web indiqué à coté des formats.  
Für die Artikelverfügbarkeit: [www.tuscaniagres.it](http://www.tuscaniagres.it)  
web code eingeben, an der Seite von Formaten angedeutet.

Impasto Colorato  
Colored Body  
Masse Colorée  
Durchgefärbt



R11  
FP2

HD

V3



HIGH

RS Rettificato/Strutturato  
Rectified/Textured

greige



L7V9 | 90x90 cm 36"x36" FP2

RS 74,08

brun

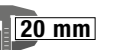

L8V0 | 90x90 cm 36"x36" FP2

RS 74,08

blanc



L7V8 | 90x90 cm 36"x36" FP2

RS 74,08

gris

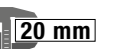

L8V1 | 90x90 cm 36"x36" FP2

RS 74,08

## FP2 pezzi speciali - special pieces - pièces spéciales - formteile



elemento "L"  
45x90x5 cm 18"x36" x2" **154,33/PZ**  
greige  
brun  
blanc  
gris

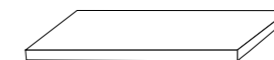

angolare elemento "L"  
45x90x5 cm 18"x36" x2" **228,40/PZ**  
greige  
brun  
blanc  
gris

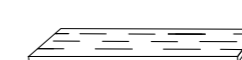

griglia  
20x90 cm 8"x36" R **195,99/PZ**  
greige  
brun  
blanc  
gris

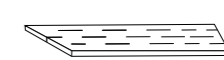

angolo SX  
greige  
brun  
blanc  
gris



angolo DX  
griglia angolo 20x90 cm 8"x36" R **419,76/coppia**  
greige  
brun  
blanc  
gris

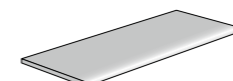

round lineare  
45x90 cm 18"x36" **138,89/PZ**  
greige  
brun  
blanc  
gris



angolo SX  
angolo DX  
round angolare 45x90 cm 18"x36" **326,55/coppia**  
greige  
brun  
blanc  
gris

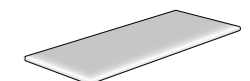

angolo SX  
greige  
brun  
blanc  
gris

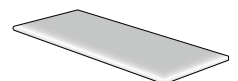

angolo DX  
angolo bordo toro 45x90 cm 18"x36" **222,23/PZ**  
greige  
brun  
blanc  
gris

Note - Notes - Notes - Anmerkungen

I pezzi speciali FP2 vengono venduti al pezzo e solo su ordinazione (tempo minimo di consegna 20 gg lavorativi dall'ordine).  
The special pieces FP2 are sold by piece and only on request (minimum delivery time 20 working days from date of order).  
Les pièces spéciales FP2 sont vendus à la pièce et uniquement sur commande (délai minimum de livraison 20 jours ouvrés à partir de la commande).  
Spezial Teile FP2 sind pro Stück verkauft und nur auf Bestellungen produziert. (Lieferzeiten mindesten 20 arbeitstage ab Auftragbestätigung)

# MY S'TILE

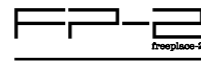

Grès porcellanato impasto colorato  
Color body porcelain stoneware . Grès cérame coloré dans la masse . Durchgefärbtes Feinsteinzeug



technical project

MY CAMEL MY SAND MY GREY



SAND FP2 | 90x90 cm RS\_36"x36" RS - 40x122,6 cm RS\_16"x48" RS - elemento a L 40x122,6x5 cm\_16"x48"x2"



# FP2 MY S'TILE

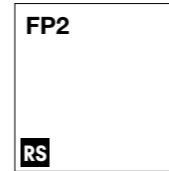

\*90x90 cm RS\_36"x36" RS  
\*my sand, my camel,  
my grey



\*40x122,6 cm RS\_16"x48" RS  
\* my sand, my grey

Per la disponibilità articolo: [www.tuscaniagres.it](http://www.tuscaniagres.it)  
digitando il codice web segnalato a lato dei formati.  
For the item's availability: [www.tuscaniagres.it](http://www.tuscaniagres.it)  
type the web code reported next to the sizes.  
Pour vérifier la disponibilité de l'article: [www.tuscaniagres.it](http://www.tuscaniagres.it)  
en saisissant le code web indiqué à côté des formats.  
Für die Artikelverfügbarkeit: [www.tuscaniagres.it](http://www.tuscaniagres.it)  
web code eingeben, an der Seite von Formaten angedeutet.

Impasto Colorato  
Colored Body  
Masse Colorée  
Durchgefärbt



R11  
FP2

HD

V3



HIGH

RS Rettificato/Strutturato  
Rectified/Textured

my grey



L0W0	90x90 cm 36"x36" FP2	RS	74,08
L9V6	40x122,6 cm 16"x48" FP2	RS	72,54

my sand



L9V8	90x90 cm 36"x36" FP2	RS	74,08
L9V7	40x122,6 cm 16"x48" FP2	RS	72,54

my camel



L9V9	90x90 cm 36"x36" FP2	RS	74,08
------	----------------------	----	-------

FP2 pezzi speciali - special pieces - pièces spéciales - formteile

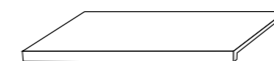

elemento "L"  
\*45x90x5 cm 18"x36" x2"  
\*40x122,6x5 cm 16"x48" x2"

154,33/PZ
361,12/PZ

\*/my sand  
\*my camel  
\*/my grey

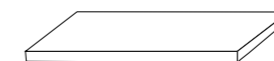

angolare elemento "L"  
\*45x90x5 cm 18"x36" x2"  
\*40x122,6x5 cm 16"x48" x2"

228,40/PZ
441,36/PZ

\*/my sand  
\*my camel  
\*/my grey

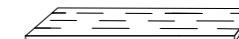

griglia  
\*20x90 cm 8"x36" R  
\*20x61 cm 8"x24" R

195,99/PZ
200,62/PZ

\*/my sand  
\*my camel  
\*/my grey



angolo SX  
griglia angolo  
\*20x90 cm 8"x36" R  
\*20x61 cm 8"x24" R

419,76/coppia
441,36/coppia

\*/my sand  
\*my camel  
\*/my grey

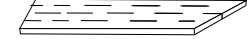

angolo DX

419,76/coppia
441,36/coppia

\*/my sand  
\*my camel  
\*/my grey



round lineare  
\*45x90 cm 18"x36"  
\*40x122,6 cm 16"x48"

138,89/PZ
317,91/PZ

\*/my sand  
\*my camel  
\*/my grey

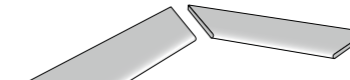

angolo SX  
round angolare  
\*45x90 cm 18"x36"  
\*40x122,6 cm 16"x48"

326,55/coppia
682,10/coppia

\*/my sand  
\*my camel  
\*/my grey



angolo SX  
angolo bordo toro  
\*45x90 cm 18"x36"  
\*40x122,6 cm 16"x48"

222,23/PZ
361,12/PZ

\*/my sand  
\*my camel  
\*/my grey



angolo DX

222,23/PZ
361,12/PZ

\*/my sand  
\*my camel  
\*/my grey

Note - Notes - Notes - Anmerkungen

I pezzi speciali FP2 vengono venduti al pezzo e solo su ordinazione (tempo minimo di consegna 20 gg lavorativi dall'ordine)  
The special pieces FP2 are sold by piece and only on request (minimum delivery time 20 working days from date of order).  
Les pièces spéciales FP2 sont vendus à la pièce et uniquement sur commande (délai minimum de livraison 20 jours ouvrés à partir de la commande).  
Spezial Teile FP2 sind pro Stück verkauft und nur auf Bestellungen produziert. (Lieferzeiten mindesten 20 arbeitstage ab Auftragbestätigung)

# LIMESTONE

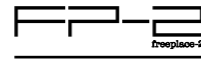

*Grès porcellanato impasto colorato*  
*Color body porcelain stoneware . Grès cérame coloré dans la masse . Durchgefärbtes feinsteinzeug*



*technical project*



COAL FP2 | 61,0x61,0 cm RS\_24"x24" RS - griglia 20x61,0 cm\_8"x24" - griglia angolo SX 20x61,0 cm\_8"x24" - griglia angolo DX 20x61,0 cm\_8"x24"



# FP2 LIMESTONE

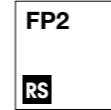

61,0x61,0 cm RS .  
 24"x24" RS

Per la disponibilità articolo: [www.tuscaniagres.it](http://www.tuscaniagres.it)  
 digitando il codice web segnalato a lato dei formati.  
 For the item's availability: [www.tuscaniagres.it](http://www.tuscaniagres.it)  
 type the web code reported next to the sizes.  
 Pour vérifier la disponibilité de l'article: [www.tuscaniagres.it](http://www.tuscaniagres.it)  
 en saisissant le code web indiqué à coté des formats.  
 Für die Artikelverfügbarkeit: [www.tuscaniagres.it](http://www.tuscaniagres.it)  
 web code eingeben, an der Seite von Formaten angedeutet.

Impasto Colorato  
 Colored Body  
 Masse Colorée  
 Durchgefärbt



**RS** Rettificato/Strutturato  
 Rectified/Textured

coal



**L5W9** | 61,0x61,0 cm 24"x24" FP2

**RS** **67,90**

ash



**L8X9** | 61,0x61,0 cm 24"x24" FP2

**RS** **67,90**

beige



**L4W9** | 61,0x61,0 cm 24"x24" FP2

**RS** **67,90**

FP2 pezzi speciali - special pieces - pièces spéciales - formteile

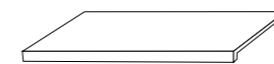

elemento "L"  
 30x61,0x5 cm 12"x24"x2" **100,00/PZ**  
 coal  
 beige  
 ash

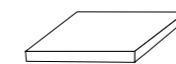

angolare elemento "L"  
 30x30x5 cm 12"x12"x2" **117,59/PZ**  
 coal  
 beige  
 ash

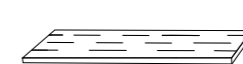

griglia  
 20x61,0 cm 8"x24" R **117,59/PZ**  
 coal  
 beige  
 ash



angolo SX  
 griglia angolo 20x61,0 cm 8"x24" R **256,17/coppia**  
 coal  
 beige  
 ash

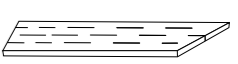

angolo DX  
 griglia angolo 20x61,0 cm 8"x24" R **256,17/coppia**  
 coal  
 beige  
 ash



round lineare  
 30x61,0 cm 12"x24" **100,00/PZ**  
 coal  
 beige  
 ash

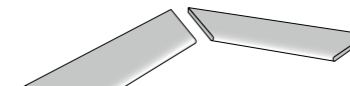

angolo SX  
 round angolare 30x61,0 cm 12"x24" **234,57/coppia**  
 coal  
 beige  
 ash

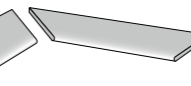

angolo DX  
 round angolare 30x61,0 cm 12"x24" **234,57/coppia**  
 coal  
 beige  
 ash



angolo SX  
 angolo bordo toro 30x61,0 cm 12"x24" **145,06/PZ**  
 coal  
 beige  
 ash



angolo DX  
 angolo bordo toro 30x61,0 cm 12"x24" **145,06/PZ**  
 coal  
 beige  
 ash

Note - Notes - Notes - Anmerkungen

I pezzi speciali FP2 vengono venduti al pezzo e solo su ordinazione (tempo minimo di consegna 20 gg lavorativi dall'ordine).  
 The special pieces FP2 are sold by piece and only on request (minimum delivery time 20 working days from date of order).  
 Les pièces spéciales FP2 sont vendus à la pièce et uniquement sur commande (délai minimum de livraison 20 jours ouvrés à partir de la commande).  
 Spezial Teile FP2 sind pro Stück verkauft und nur auf Bestellungen produziert. (Lieferzeiten mindesten 20 arbeitstage ab Auftragbestätigung)

# TECHNIKA

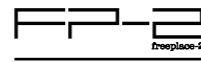

Grès porcellanato impasto colorato  
Color body porcelain stoneware . Grès cérame coloré dans la masse . Durchgefärbtes feinsteinzeug



technical project



ANTRACITE FP2 | 61,0x61,0 cm RS\_24"x24" RS



# FP2 TECHNICA

FP2

NS RS

61,5x61,5 cm NS .  
24"x24" NS  
61,0x61,0 cm RS .  
24"x24" RS

Per la disponibilità articolo: [www.tuscaniagres.it](http://www.tuscaniagres.it)  
digitando il codice web segnalato a lato dei formati.  
For the item's availability: [www.tuscaniagres.it](http://www.tuscaniagres.it)  
type the web code reported next to the sizes.  
Pour vérifier la disponibilité de l'article: [www.tuscaniagres.it](http://www.tuscaniagres.it)  
en saisissant le code web indiqué à coté des formats.  
Für die Artikelverfügbarkeit: [www.tuscaniagres.it](http://www.tuscaniagres.it)  
web code eingeben, an der Seite von Formaten angeedeutet.

Impasto Colorato  
Colored Body  
Masse Colorée  
Durchgefärbt



R11  
FP2

HD

V2



MODERATE

NS Naturale/Strutturato -  
Natural/Textured

RS Rettificato/Strutturato -  
Rectified/Textured

grigio



I6H9 | 61,5x61,5 cm 24"x24" FP2  
I5O2 | 61,0x61,0 cm 24"x24" FP2

NS 55,56  
RS 67,90

antracite



I3I1 | 61,5x61,5 cm 24"x24" FP2  
I8N3 | 61,0x61,0 cm 24"x24" FP2

NS 55,56  
RS 67,90

## FP2 pezzi speciali - special pieces - pièces spéciales - formteile

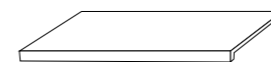

elemento "L"  
30x61,5x5 cm 12"x24"x2" 100,00/PZ  
grigio  
antracite



angolare elemento "L"  
30x30x5 cm 12"x12"x2" 117,59/PZ  
grigio  
antracite

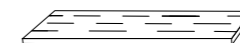

griglia  
20x61,0 cm 8"x24" R R 117,59/PZ  
grigio  
antracite



angolo SX  
griglia angolo 20x61,0 cm 8"x24" R R 256,17/coppia  
grigio  
antracite

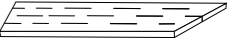

angolo DX  
grigio  
antracite



round lineare  
30x61,5 cm 12"x24" 100,00/PZ  
grigio  
antracite

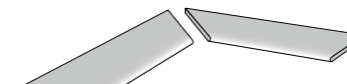

angolo SX  
angolo DX  
round angolare 30x61,5 cm 12"x24" 234,57/coppia  
grigio  
antracite



angolo SX  
angolo bordo toro 30x61,5 cm 12"x24" 145,06/PZ  
grigio  
antracite



angolo DX  
grigio  
antracite

Note - Notes - Notes - Anmerkungen

I pezzi speciali FP2 vengono venduti al pezzo e solo su ordinazione (tempo minimo di consegna 20 gg lavorativi dall'ordine)  
The special pieces FP2 are sold by piece and only on request (minimum delivery time 20 working days from date of order).  
Les pièces spéciales FP2 sont vendus à la pièce et uniquement sur commande (délai minimum de livraison 20 jours ouvrés à partir de la commande).  
Spezial Teile FP2 sind pro Stück verkauft und nur auf Bestellungen produziert. (Lieferzeiten mindesten 20 arbeitstage ab Auftragbestätigung)

# GREY SOUL

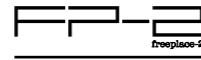

Grès porcellanato impasto colorato  
Color body porcelain stoneware . Grès cérame coloré dans la masse . Durchgefärbtes feinsteinzeug



technical project

SAND LIGHT MID DARK



DARK e LIGHT FP2 | 61,5x61,5 cm NS\_24"x24" NS



# FP2 GREY SOUL

Impasto Colorato  
Colored Body  
Masse Colorée  
Durchgefärbt



**NS** Naturale/Strutturato -  
Natural/Textured

**RS** Rettificato/Strutturato -  
Rectified/Textured

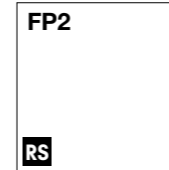

\*90x90 cm RS .  
36"x36" RS  
\*sand, mid, dark

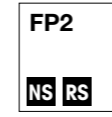

\*61,5x61,5 cm NS . 24"x24" NS  
\*61,0x61,0 cm RS . 24"x24" RS  
\*sand, light, mid, dark



\*40x122,6 cm RS . 16"x48" RS  
\*light, mid, dark

Per la disponibilità articolo: [www.tuscaniagres.it](http://www.tuscaniagres.it) digitando il codice web segnalato a lato dei formati.  
For the item's availability: [www.tuscaniagres.it](http://www.tuscaniagres.it) type the web code reported next to the sizes.  
Pour vérifier la disponibilité de l'article: [www.tuscaniagres.it](http://www.tuscaniagres.it) en saisissant le code web indiqué à côté des formats.  
Für die Artikelverfügbarkeit: [www.tuscaniagres.it](http://www.tuscaniagres.it) web code eingeben, an der Seite von Formaten angedeutet.

sand



L5T2	90x90 cm 36"x36" FP2	RS	74,08
I1H7	61,5x61,5 cm 24"x24" FP2	NS	55,56
I7H0	61,0x61,0 cm 24"x24" FP2	RS	67,90

light



H3U6	61,5x61,5 cm 24"x24" FP2	NS	55,56
H3U7	61,0x61,0 cm 24"x24" FP2	RS	67,90
L8T8	40x122,6 cm 16"x48" FP2	RS	72,54

mid



L5T1	90x90 cm 36"x36" FP2	RS	74,08
H3U8	61,5x61,5 cm 24"x24" FP2	NS	55,56
H3U9	61,0x61,0 cm 24"x24" FP2	RS	67,90
L8T7	40x122,6 cm 16"x48" FP2	RS	72,54

dark



L5T0	90x90 cm 36"x36" FP2	RS	74,08
H4U0	61,5x61,5 cm 24"x24" FP2	NS	55,56
H4U1	61,0x61,0 cm 24"x24" FP2	RS	67,90
L8T9	40x122,6 cm 16"x48" FP2	RS	72,54

FP2 pezzi speciali - special pieces - pièces spéciales - formteile

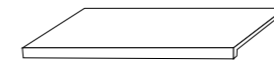

elemento "L"	*45x90x5 cm 18"x36" x2"	154,33/PZ
	*30x61,5x5 cm 12"x24" x2"	100,00/PZ
	*40x122,6x5 cm 16"x48" x2"	361,12/PZ

\*/• sand  
\*/▲ light  
\*/•▲ mid  
\*/•▲ dark

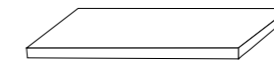

angolare elemento "L"	*45x90x5 cm 18"x36" x2"	228,40/PZ
	*30x30x5 cm 12"x12" x2"	117,59/PZ
	*40x122,6x5 cm 16"x48" x2"	441,36/PZ

\*/• sand  
\*/▲ light  
\*/•▲ mid  
\*/•▲ dark

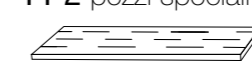

griglia	*20x90 cm 8"x36" R	195,99/PZ
	*20x61 cm 8"x24" R	117,59/PZ
	*20x61 cm 8"x24" R	200,62/PZ

\*/• sand  
\*/▲ light  
\*/•▲ mid  
\*/•▲ dark

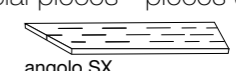

angolo SX	griglia angolo *20x90 cm 8"x36" R	419,76/coppia
	*20x61,0 cm 8"x24" R	256,17/coppia
	*20x61,0 cm 8"x24" R	441,36/coppia

\*/• sand  
\*/▲ light  
\*/•▲ mid  
\*/•▲ dark

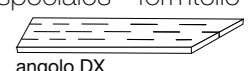

angolo DX	griglia angolo *20x90 cm 8"x36" R	419,76/coppia
	*20x61,0 cm 8"x24" R	256,17/coppia
	*20x61,0 cm 8"x24" R	441,36/coppia

\*/• sand  
\*/▲ light  
\*/•▲ mid  
\*/•▲ dark



round lineare	*45x90 cm 18"x36"	138,89/PZ
	*30x61,5 cm 12"x24"	100,00/PZ
	*40x122,6 cm 16"x48"	317,91/PZ

\*/• sand  
\*/▲ light  
\*/•▲ mid  
\*/•▲ dark

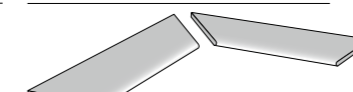

angolo SX	angolo DX	326,55/coppia
round angolare	*45x90 cm 18"x36"	234,57/coppia
	*30x61,5 cm 12"x24"	682,10/coppia
	*40x122,6 cm 16"x48"	

\*/• sand  
\*/▲ light  
\*/•▲ mid  
\*/•▲ dark

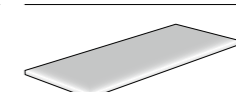

angolo SX	angolo DX	222,23/PZ
angolo bordo toro	*45x90 cm 18"x36"	145,06/PZ
	*30x61,5 cm 12"x24"	361,12/PZ
	*40x122,6 cm 16"x48"	

\*/• sand  
\*/▲ light  
\*/•▲ mid  
\*/•▲ dark

Note - Notes - Notes - Anmerkungen  
I pezzi speciali FP2 vengono venduti al pezzo e solo su ordinazione (tempo minimo di consegna 20 gg lavorativi dall'ordine).  
The special pieces FP2 are sold by piece and only on request (minimum delivery time 20 working days from date of order).  
Les pièces spéciales FP2 sont vendues à la pièce et uniquement sur commande (délai minimum de livraison 20 jours ouvrés à partir de la commande).  
Spezial Teile FP2 sind pro Stück verkauft und nur auf Bestellungen produziert. (Lieferzeiten mindesten 20 arbeitstage ab Auftragsbestätigung)

# METEORA



*Grès porcellanato impasto colorato*  
*Color body porcelain stoneware . Grès cérame coloré dans la masse . Durchgefärbtes feinsteinzeug*



*technical project*



*Una linea di alto impatto estetico,  
risultato di un ricercato progetto basato su una tecnologia  
d'avanguardia specifica per gli alti spessori.*

*La materia ceramica si modifica e si evolve secondo schemi tradizionali  
che hanno come termine di paragone la pietra naturale.*

*A captivating line resulting from a detailed project based  
on cutting-edge technology specific for high thicknesses.  
The ceramic material changes and evolves according  
to traditional schemes inspired by natural stone.*

*Une ligne esthétiquement très impactante, issue d'un projet complexe basé  
sur une technologie de pointe, spécifique pour les épaisseurs majorées.*

*La matière céramique change et évolue selon des schémas  
traditionnels inspirés de la pierre naturelle.*

*Eine Serie mit einem hohen ästhetischen Eindruck, Ergebnis eines  
erlesenen Projekts, das sich auf eine spezifische fortschrittliche  
Technologie für hohe Stärken stützt.*

*Die Materie Keramik ändert und entwickelt sich gemäß  
traditionellen Schemen, die als Inspiration Naturstein nutzen.*

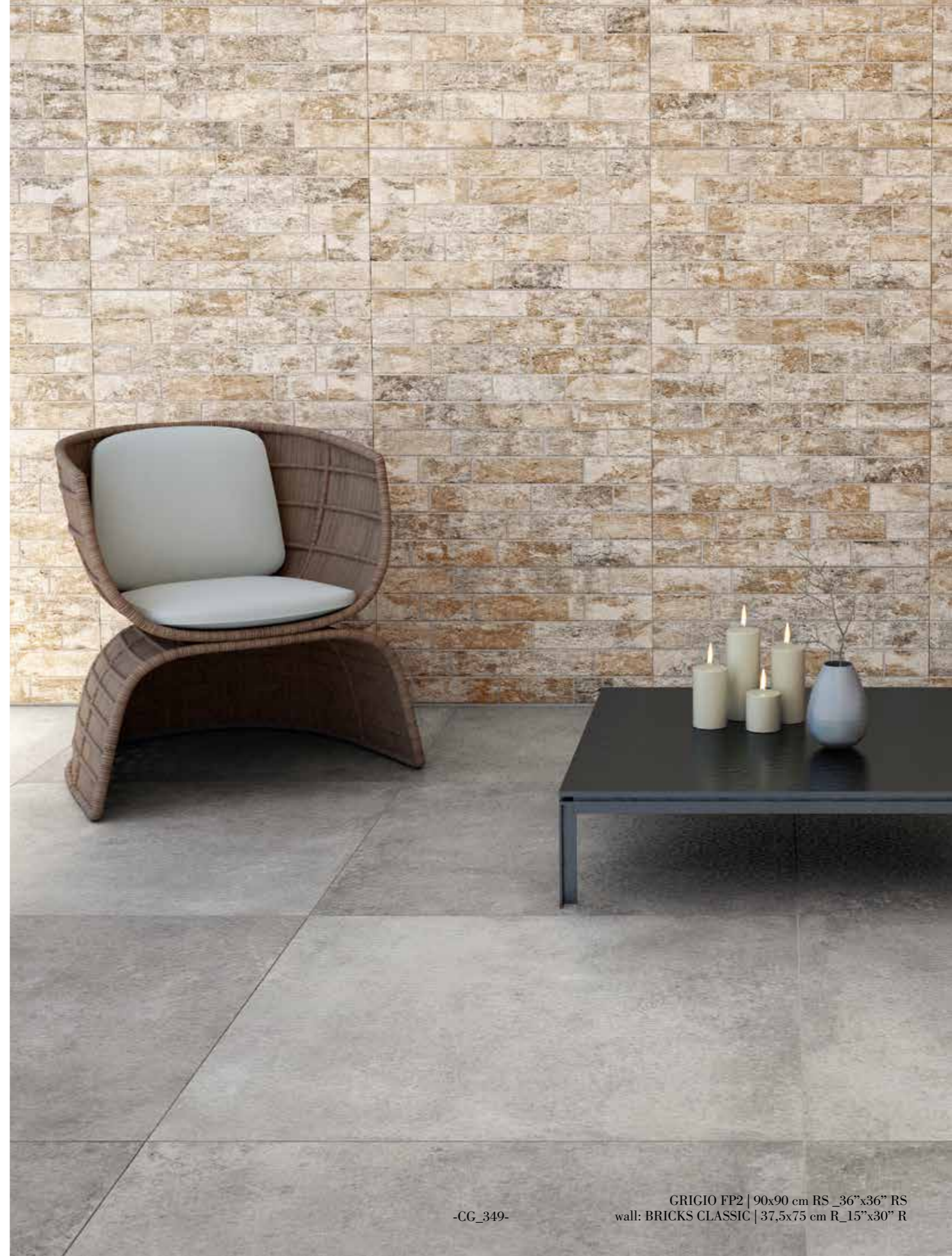



# METEORA FP2

Impasto Colorato  
Colored Body  
Masse Colorée  
Durchgefärbt



**NS** Naturale/Strutturato  
Natural/Textured

**RS** Rettificato/Strutturato  
Rectified/Textured

beige



L5T9	90x90 cm 36"x36" FP2	NS	61,73
L5T4	90x90 cm 36"x36" FP2	RS	74,08
L6T2	61,5x61,5 cm 24"x24" FP2	NS	55,56
L6T5	61,0x61,0 cm 24"x24" FP2	RS	67,90
L7W2	61,0x61,0 cm 24"x24" DECORO FP2	RS	77,17

cotto



L6T0	90x90 cm 36"x36" FP2	NS	61,73
L5T5	90x90 cm 36"x36" FP2	RS	74,08

grigio



L5T7	90x90 cm 36"x36" FP2	NS	61,73
L5T6	90x90 cm 36"x36" FP2	RS	74,08
L6T3	61,5x61,5 cm 24"x24" FP2	NS	55,56
L0U7	61,0x61,0 cm 24"x24" FP2	RS	67,90
L7W3	61,0x61,0 cm 24"x24" DECORO FP2	RS	77,17

mix



L6T1	61,5x61,5 cm 24"x24" FP2	NS	55,56
L6T4	61,0x61,0 cm 24"x24" FP2	RS	67,90
L7W4	61,0x61,0 cm 24"x24" DECORO FP2	RS	77,17

GRIGIO FP2 | 90x90 cm RS\_36"x36" RS



## METEORA

Per la disponibilità articolo: [www.tuscaniagres.it](http://www.tuscaniagres.it)  
digitando il codice web segnalato a lato dei formati.  
For the item's availability: [www.tuscaniagres.it](http://www.tuscaniagres.it)  
type the web code reported next to the sizes.  
Pour vérifier la disponibilité de l'article: [www.tuscaniagres.it](http://www.tuscaniagres.it)  
en saisissant le code web indiqué à côté des formats.  
Für die Artikelverfügbarkeit: [www.tuscaniagres.it](http://www.tuscaniagres.it)  
web code eingeben, an der Seite von Formaten angedeutet.

## FP2 pezzi speciali - special pieces - pièces spéciales - fornteile

 elemento "L" *45x90x5 cm 18"x36" x2" *30x61,5x5 cm 12"x24" x2" 154,33/PZ 100,00/PZ /*beige *cotto /*grigio *mix	 angolare elemento "L" *45x90x5 cm 18"x36" x2" *30x30x5 cm 12"x12" x2" 228,40/PZ 117,59/PZ /*beige *cotto /*grigio *mix	 griglia *20x90 cm 8"x36" R *20x61,0 cm 8"x24" R 195,99/PZ 117,59/PZ /*beige *cotto /*grigio *mix	 angolo SX griglia angolo *20x90 cm 8"x36" R *20x61,0 cm 8"x24" R 419,76/coppia 256,17/coppia /*beige *cotto /*grigio *mix
 round lineare *45x90 cm 18"x36" *30x61,5 cm 12"x24" 138,89/PZ 100,00/PZ /*beige *cotto /*grigio *mix	 angolo SX round angolare *45x90 cm 18"x36" *30x61,5 cm 12"x24" 326,55/coppia 234,57/coppia /*beige *cotto /*grigio *mix	 angolo SX angolo bordo toro *45x90 cm 18"x36" *30x61,5 cm 12"x24" 222,23/PZ 145,06/PZ /*beige *cotto /*grigio *mix	

Note - Notes - Notes - Anmerkungen

I pezzi speciali FP2 vengono venduti al pezzo e solo su ordinazione (tempo minimo di consegna 20 gg lavorativi dall'ordine).  
The special pieces FP2 are sold by piece and only on request (minimum delivery time 20 working days from date of order).  
Les pièces spéciales FP2 sont vendus à la pièce et uniquement sur commande (délai minimum de livraison 20 jours ouvrés à partir de la commande).  
Spezial Teile FP2 sind pro Stück verkauft und nur auf Bestellungen produziert. (Lieferzeiten mindesten 20 arbeitstage ab Auftragsbestätigung)

# PIERRE BLEUE

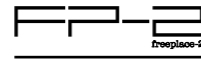

Grès porcellanato impasto colorato  
Color body porcelain stoneware . Grès cérame coloré dans la masse . Durchgefärbtes feinsteinzeug



technical project



outdoor: ANTIQUE FP2 | 61,0x61,0 cm RS\_24"x24" RS  
indoor: FONCÉ | 61,0x61,0 cm R\_24"x24" R



# FP2 PIERRE BLEUE

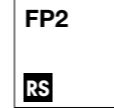

\*61,0x61,0 cm RS . 24"x24" RS  
\*clair, foncé, antique

Per la disponibilità articolo: [www.tuscaniagres.it](http://www.tuscaniagres.it)  
digitando il codice web segnalato a lato dei formati.  
For the item's availability: [www.tuscaniagres.it](http://www.tuscaniagres.it)  
type the web code reported next to the sizes.  
Pour vérifier la disponibilité de l'article: [www.tuscaniagres.it](http://www.tuscaniagres.it)  
en saisissant le code web indiqué à côté des formats.  
Für die Artikelverfügbarkeit: [www.tuscaniagres.it](http://www.tuscaniagres.it)  
web code eingeben, an der Seite von Formaten angedeutet.

Impasto Colorato  
Colored Body  
Masse Colorée  
Durchgefärbt



RS Rettificato/Strutturato -  
Rectified/Textured

clair



L1U7 | 61,0x61,0 cm 24"x24" FP2

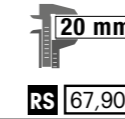

antique



J2Q7 | 61,0x61,0 cm 24"x24" FP2

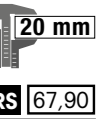

foncé



L1U8 | 61,0x61,0 cm 24"x24" FP2

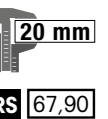

FP2 pezzi speciali - special pieces - pièces spéciales - formteile

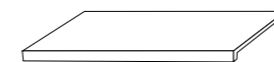

elemento "L"  
30x61,0x5 cm 12"x24"x2" **100,00/PZ**  
clair  
foncé  
antique



angolare elemento "L"  
30x30x5 cm 12"x12"x2" **117,59/PZ**  
clair  
foncé  
antique

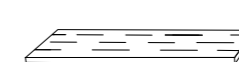

griglia  
20x61,0 cm 8"x24" R **117,59/PZ**  
clair  
foncé  
antique

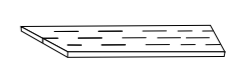

angolo SX  
griglia angolo 20x61,0 cm 8"x24" R **256,17/coppia**  
clair  
foncé  
antique

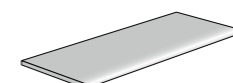
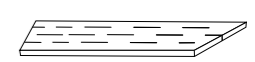

round lineare  
30x61,0 cm 12"x24" **100,00/PZ**  
clair  
foncé  
antique



angolo SX  
round angolare 30x61,0 cm 12"x24" **234,57/coppia**  
clair  
foncé  
antique

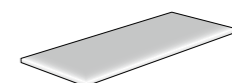

angolo SX  
angolo bordo toro 30x61,0 cm 12"x24" **145,06/PZ**  
clair  
foncé  
antique

Note - Notes - Notes - Anmerkungen

I pezzi speciali FP2 vengono venduti al pezzo e solo su ordinazione (tempo minimo di consegna 20 gg lavorativi dall'ordine).  
The special pieces FP2 are sold by piece and only on request (minimum delivery time 20 working days from date of order).  
Les pièces spéciales FP2 sont vendus à la pièce et uniquement sur commande (délai minimum de livraison 20 jours ouvrés à partir de la commande).  
Spezial Teile FP2 sind pro Stück verkauft und nur auf Bestellungen produziert. (Lieferzeiten mindesten 20 arbeitstage ab Auftragbestätigung)

# COR-STONE

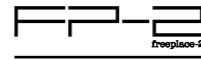

Grès porcellanato impasto colorato  
Color body porcelain stoneware . Grès cérame coloré dans la masse . Durchgefärbtes Feinsteinzeug



technical project

DARK



DARK FP2 | 61,5x61,5 cm NS\_24"x24" NS

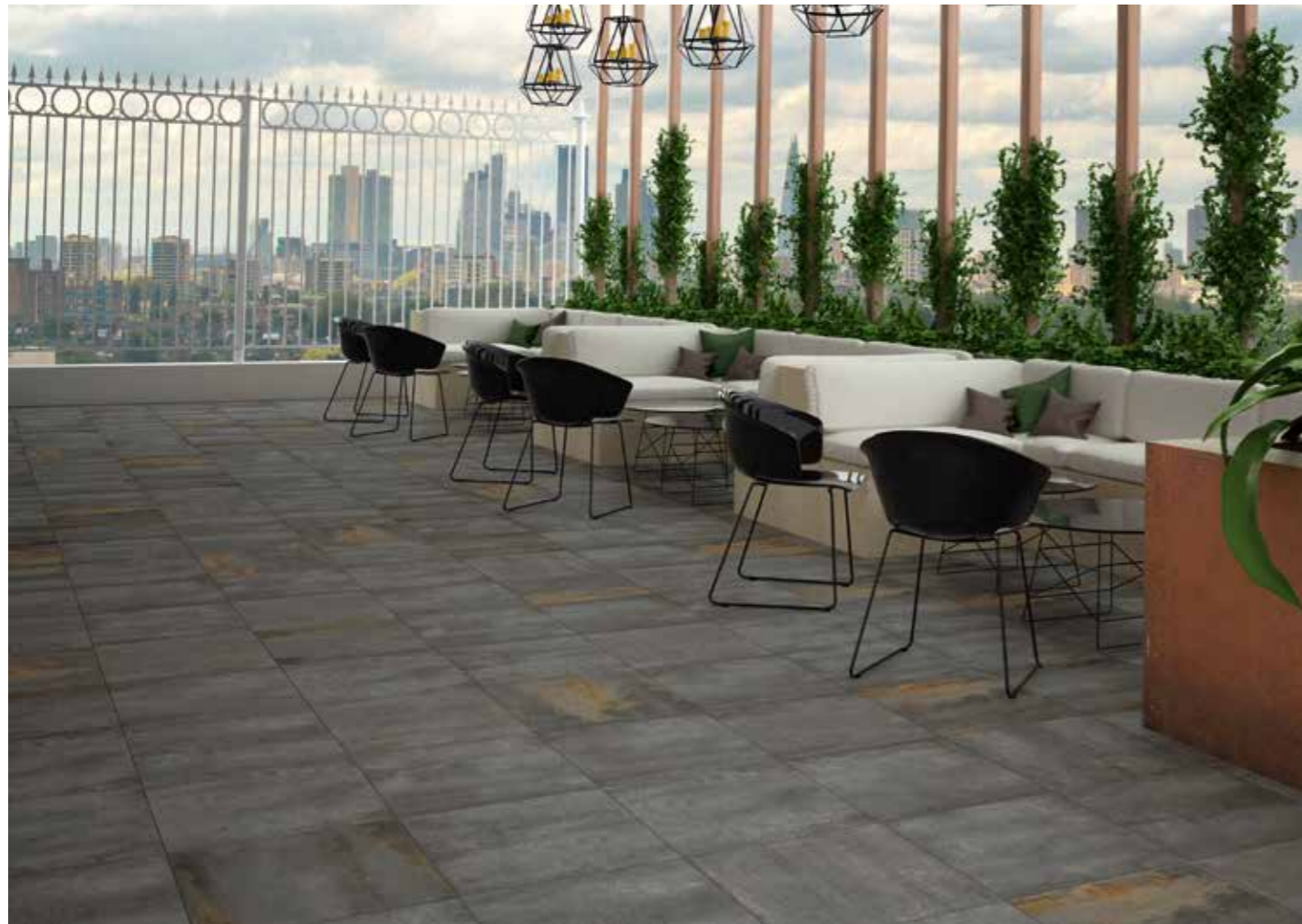

# FP2 COR-STONE

FP2

NS RS

61,5x61,5 cm NS .  
24"x24" NS  
61,0x61,0 cm RS.  
24"x24" RS

FP2

RS

40x122,6 cm RS .  
16"x48" RS

Per la disponibilità articolo: [www.tuscaniagres.it](http://www.tuscaniagres.it)  
digitando il codice web segnalato a lato dei formati.  
For the item's availability: [www.tuscaniagres.it](http://www.tuscaniagres.it)  
type the web code reported next to the sizes.  
Pour vérifier la disponibilité de l'article: [www.tuscaniagres.it](http://www.tuscaniagres.it)  
en saisissant le code web indiqué à coté des formats.  
Für die Artikelverfügbarkeit: [www.tuscaniagres.it](http://www.tuscaniagres.it)  
web code eingeben, an der Seite von Formaten angedeutet.



R11  
FP2

HD

V4



NS Naturale/Strutturato -  
Natural/Textured

RS Rettificato/Strutturato -  
Rectified/Textured

dark



L7R0	61,5x61,5 cm 24"x24" FP2	NS	55,56
L7R1	61,0x61,0 cm 24"x24" FP2	RS	67,90
L2U1	40x122,6 cm 16"x48" FP2	RS	72,54

## FP2 pezzi speciali - special pieces - pièces spéciales - formteile

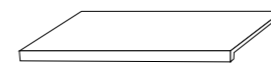

elemento "L"  
30x61,5x5 cm 12"x24"x2"  
40x122,6x5 cm 16"x48"x2"

100,00/PZ

361,12/PZ

dark

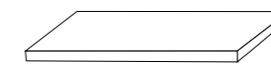

angolare elemento "L"  
30x30x5 cm 12"x12"x2"  
40x122,6x5 cm 16"x48"x2"

117,59/PZ

441,36/PZ

dark

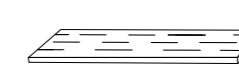

griglia  
20x61,0 cm 8"x24" R  
20x61 cm 8"x24" R

117,59/PZ

200,62/PZ

dark

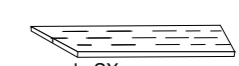

angolo SX  
griglia angolo  
20x61,0 cm 8"x24" R  
20x61 cm 8"x24" R

256,17/coppia

441,36/coppia

dark

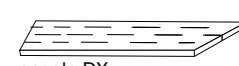

angolo DX  
griglia angolo  
20x61,0 cm 8"x24" R  
20x61 cm 8"x24" R

256,17/coppia

441,36/coppia

dark

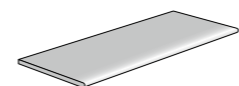

round lineare  
30x61,5 cm 12"x24"  
40x122,6 cm 16"x48"

100,00/PZ

317,91/PZ

dark

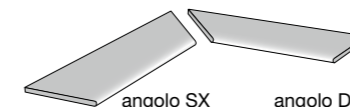

round angolare  
30x61,5 cm 12"x24"  
40x122,6 cm 16"x48"

234,57/coppia

682,10/coppia

dark

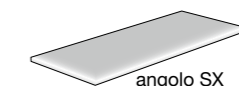

angolo bordo toro  
30x61,5 cm 12"x24"  
40x122,6 cm 16"x48"

145,06/PZ

361,12/PZ

dark

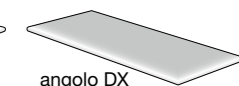

angolo DX  
30x61,5 cm 12"x24"  
40x122,6 cm 16"x48"

145,06/PZ

361,12/PZ

dark

Note - Notes - Notes - Anmerkungen

I pezzi speciali FP2 vengono venduti al pezzo e solo su ordinazione (tempo minimo di consegna 20 gg lavorativi dall'ordine)  
The special pieces FP2 are sold by piece and only on request (minimum delivery time 20 working days from date of order).  
Les pièces spéciales FP2 sont vendus à la pièce et uniquement sur commande (délai minimum de livraison 20 jours ouvrés à partir de la commande).  
Spezial Teile FP2 sind pro Stück verkauft und nur auf Bestellungen produziert. (Lieferzeiten mindesten 20 arbeitstage ab Auftragbestätigung)

# DURANGO

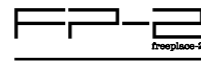

Grès porcellanato impasto colorato  
Color body porcelain stoneware . Grès cérame coloré dans la masse . Durchgefärbtes Feinsteinzeug



technical project

MEDIUM



MEDIUM FP2 | 61,5x61,5 cm NS\_24"x24" NS



-CG\_356-

# FP2 DURANGO

FP2

NS RS

61,5x61,5 cm NS . 24"x24" NS  
61,0x61,0 cm RS . 24"x24" RS

Per la disponibilità articolo: [www.tuscaniagres.it](http://www.tuscaniagres.it)  
digitando il codice web segnalato a lato dei formati.  
For the item's availability: [www.tuscaniagres.it](http://www.tuscaniagres.it)  
type the web code reported next to the sizes.  
Pour vérifier la disponibilité de l'article: [www.tuscaniagres.it](http://www.tuscaniagres.it)  
en saisissant le code web indiqué à coté des formats.  
Für die Artikelverfügbarkeit: [www.tuscaniagres.it](http://www.tuscaniagres.it)  
web code eingeben, an der Seite von Formaten angedeutet.

Impasto Colorato  
Colored Body  
Masse Colorée  
Durchgefärbt



R11  
FP2

HD

V4



RANDOM

NS Naturale/Strutturato -  
Natural/Textured

RS Rettificato/Strutturato -  
Rectified/Textured

medium



J0Q0 | 61,5x61,5 cm 24"x24" FP2

NS | 55,56

I4Z2 | 61,0x61,0 cm 24"x24" FP2

RS | 67,90

## FP2 pezzi speciali - special pieces - pièces spéciales - formteile

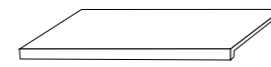

elemento "L"  
30x61,5x5 cm 12"x24"x2" **100,00/PZ**  
medium

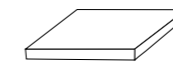

angolare elemento "L"  
30x30x5 cm 12"x12"x2" **117,59/PZ**  
medium

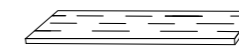

griglia  
20x61,0 cm 8"x24" R **117,59/PZ**  
medium

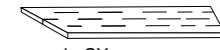

angolo SX  
griglia angolo 20x61,0 cm 8"x24" R **256,17/coppia**  
medium

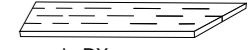

angolo DX  
griglia angolo 20x61,0 cm 8"x24" R **256,17/coppia**  
medium



round lineare  
30x61,5 cm 12"x24" **100,00/PZ**  
medium

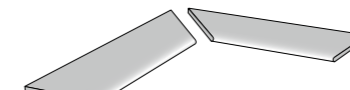

angolo SX  
angolo DX  
round angolare 30x61,5 cm 12"x24" **234,57/coppia**  
medium



angolo SX  
angolo bordo toro 30x61,5 cm 12"x24" **145,06/PZ**  
medium

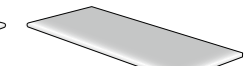

angolo DX  
angolo bordo toro 30x61,5 cm 12"x24" **145,06/PZ**  
medium

Note - Notes - Notes - Anmerkungen

I pezzi speciali FP2 vengono venduti al pezzo e solo su ordinazione (tempo minimo di consegna 20 gg lavorativi dall'ordine).  
The special pieces FP2 are sold by piece and only on request (minimum delivery time 20 working days from date of order).  
Les pièces spéciales FP2 sont vendus à la pièce et uniquement sur commande (délai minimum de livraison 20 jours ouvrés à partir de la commande).  
Spezial Teile FP2 sind pro Stück verkauft und nur auf Bestellungen produziert. (Lieferzeiten mindesten 20 Arbeitstage ab Auftragbestätigung)

-CG\_357-

# EDELWEISS

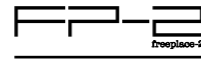

Grès porcellanato impasto colorato  
Color body porcelain stoneware . Grès cérame coloré dans la masse . Durchgefärbtes Feinsteinzeug



technical project



GREY FP2 | 61,5x61,5 cm NS\_24"x24" NS - elemento a L 30x61,5x5 cm\_12"x24"x2" - angolare elemento a L 30x30x5 cm\_12"x12"x2" - griglia 20x61,0 cm\_8"x24" - griglia angolo SX 20x61,0 cm\_8"x24" - griglia angolo DX 20x61,0 cm\_8"x24"



# FP2 EDELWEISS

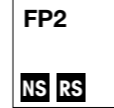

61,5x61,5 cm NS . 24"x24" NS  
61,0x61,0 cm RS . 24"x24" RS

Per la disponibilità articolo: [www.tuscaniagres.it](http://www.tuscaniagres.it) digitando il codice web segnalato a lato dei formati.  
For the item's availability: [www.tuscaniagres.it](http://www.tuscaniagres.it) type the web code reported next to the sizes.  
Pour vérifier la disponibilité de l'article: [www.tuscaniagres.it](http://www.tuscaniagres.it) en saisissant le code web indiqué à coté des formats.  
Für die Artikelverfügbarkeit: [www.tuscaniagres.it](http://www.tuscaniagres.it) web code eingeben, an der Seite von Formaten angedeutet.

Impasto Colorato  
Colored Body  
Masse Colorée  
Durchgefärbt



**NS** Naturale/Strutturato - Natural/Textured  
**RS** Rettificato/Strutturato - Rectified/Textured

grey



I709 | 61,5x61,5 cm 24"x24" FP2  
I1U8 | 61,0x61,0 cm 24"x24" FP2

NS 55,56  
RS 67,90

coal



I708 | 61,5x61,5 cm 24"x24" FP2  
I1U9 | 61,0x61,0 cm 24"x24" FP2

NS 55,56  
RS 67,90

## FP2 pezzi speciali - special pieces - pièces spéciales - formteile

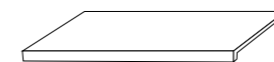

elemento "L"  
30x61,5x5 cm 12"x24"x2" **100,00/PZ**  
grey  
coal



angolare elemento "L"  
30x30x5 cm 12"x12"x2" **117,59/PZ**  
grey  
coal

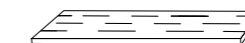

griglia  
20x61,0 cm 8"x24" R **117,59/PZ**  
grey  
coal



angolo SX  
griglia angolo 20x61,0 cm 8"x24" R **256,17/coppia**  
grey  
coal

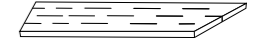

angolo DX  
griglia angolo 20x61,0 cm 8"x24" R **256,17/coppia**  
grey  
coal



round lineare  
30x61,5 cm 12"x24" **100,00/PZ**  
grey  
coal

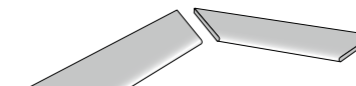

angolo SX  
round angolare 30x61,5 cm 12"x24" **234,57/coppia**  
grey  
coal



angolo SX  
angolo bordo toro 30x61,5 cm 12"x24" **145,06/PZ**  
grey  
coal



Note - Notes - Notes - Anmerkungen

I pezzi speciali FP2 vengono venduti al pezzo e solo su ordinazione (tempo minimo di consegna 20 gg lavorativi dall'ordine)  
The special pieces FP2 are sold by piece and only on request (minimum delivery time 20 working days from date of order).  
Les pièces spéciales FP2 sont vendus à la pièce et uniquement sur commande (délai minimum de livraison 20 jours ouvrés à partir de la commande).  
Spezial Teile FP2 sind pro Stück verkauft und nur auf Bestellungen produziert. (Lieferzeiten mindesten 20 arbeitstage ab Auftragbestätigung)

# TERRAFORTE

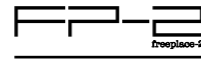

Grès porcellanato smaltato  
Glazed porcelain stoneware . Grès cérame émaillé . Glasiertes feinsteinzeug



technical project

CENERE



CENERE FP2 | 61,5x61,5 cm NS/BD\_24"x24" NS/BD



-CG\_360-

# FP2 TERRAFORTE

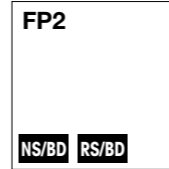

90x90 cm NS/BD .  
36"x36" NS/BD  
90x90 cm RS/BD .  
36"x36" RS/BD



61,5x61,5 cm NS/BD .  
24"x24" NS/BD  
61,0x61,0 cm RS/BD .  
24"x24" RS/BD

Per la disponibilità articolo: [www.tuscaniagres.it](http://www.tuscaniagres.it)  
digitando il codice web segnalato a lato dei formati.  
For the item's availability: [www.tuscaniagres.it](http://www.tuscaniagres.it)  
type the web code reported next to the sizes.  
Pour vérifier la disponibilité de l'article: [www.tuscaniagres.it](http://www.tuscaniagres.it)  
en saisissant le code web indiqué à côté des formats.  
Für die Artikelverfügbarkeit: [www.tuscaniagres.it](http://www.tuscaniagres.it)  
web code eingeben, an der Seite von Formaten angedeutet.

Grès porcellanato smaltato  
Glazed porcelain stoneware  
Grès cérame émaillé  
Glasiertes feinsteinzeug

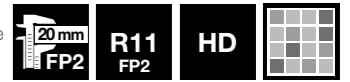

**NS/BD** Naturale strutturato/Bordo dritto  
Natural textured/Straight edges

**RS/BD** Rettificato strutturato/Bordo dritto  
Rectified textured/Straight edges

cenere



L4U7	90x90 cm 36"x36" FP2	NS/BD	61,73
L4U8	90x90 cm 36"x36" FP2	RS/BD	74,08
J9R3	61,5x61,5 cm 24"x24" FP2	NS/BD	55,56
J2Q9	61,0x61,0 cm 24"x24" FP2	RS/BD	67,90

FP2 pezzi speciali - special pieces - pièces spéciales - formteile



elemento "L"  
45x90x5 cm 18"x36"x2"  
30x61,5x5 cm 12"x24"x2"  
154,33/PZ  
100,00/PZ

cenere

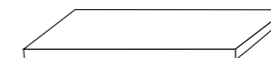

angolare elemento "L"  
45x90x5 cm 18"x36"x2"  
30x30x5 cm 12"x12"x2"  
228,40/PZ  
117,59/PZ

cenere

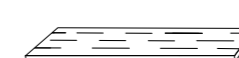

griglia  
20x90 cm 8"x36" R  
20x61,0 cm 8"x24" R  
195,99/PZ  
117,59/PZ

cenere

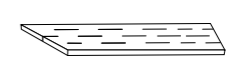

angolo SX

419,76/coppia  
256,17/coppia

cenere

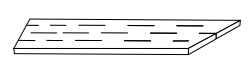

angolo DX

419,76/coppia  
256,17/coppia

cenere

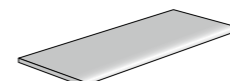

round lineare  
45x90 cm 18"x36"  
30x61,5 cm 12"x24"  
138,89/PZ  
100,00/PZ

cenere

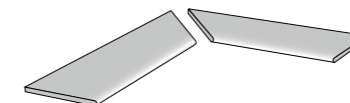

angolo SX  
round angolare 45x90 cm 18"x36"  
30x61,5 cm 12"x24"  
326,55/coppia  
234,57/coppia

cenere

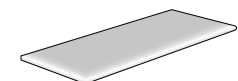

angolo SX  
angolo bordo toro 45x90 cm 18"x36"  
30x61,5 cm 12"x24"  
222,23/PZ  
145,06/PZ

cenere

Note - Notes - Notes - Anmerkungen

I pezzi speciali FP2 vengono venduti al pezzo e solo su ordinazione (tempo minimo di consegna 20 gg lavorativi dall'ordine)  
The special pieces FP2 are sold by piece and only on request (minimum delivery time 20 working days from date of order).  
Les pièces spéciales FP2 sont vendus à la pièce et uniquement sur commande (délai minimum de livraison 20 jours ouvrés à partir de la commande).  
Spezial Teile FP2 sind pro Stück verkauft und nur auf Bestellungen produziert. (Lieferzeiten mindesten 20 arbeitstage ab Auftragbestätigung)

-CG\_361-

# SPARKLY

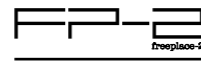

Grès porcellanato impasto colorato  
Color body porcelain stoneware . Grès cérame coloré dans la masse . Durchgefärbtes Feinsteinzeug



technical project



RUGGINE FP2 | 61,5x61,5 cm NS\_24"x24" NS



# FP2 SPARKLY

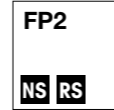

61,5x61,5 cm NS . 24"x24" NS  
61,0x61,0 cm RS . 24"x24" RS

Per la disponibilità articolo: [www.tuscaniagres.it](http://www.tuscaniagres.it)  
digitando il codice web segnalato a lato dei formati.  
For the item's availability: [www.tuscaniagres.it](http://www.tuscaniagres.it)  
type the web code reported next to the sizes.  
Pour vérifier la disponibilité de l'article: [www.tuscaniagres.it](http://www.tuscaniagres.it)  
en saisissant le code web indiqué à coté des formats.  
Für die Artikelverfügbarkeit: [www.tuscaniagres.it](http://www.tuscaniagres.it)  
web code eingeben, an der Seite von Formaten angedeutet.

Impasto Colorato  
Colored Body  
Masse Colorée  
Durchgefärbt



NS Naturale/Strutturato -  
Natural/Textured  
RS Rettificato/Strutturato -  
Rectified/Textured

ruggine



H3U2 61,5x61,5 cm 24"x24" FP2

NS 55,56

H3U5 61,0x61,0 cm 24"x24" FP2

RS 67,90

FP2 pezzi speciali - special pieces - pièces spéciales - formteile

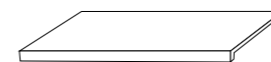

elemento "L"  
30x61,5x5 cm 12"x24"x2" 100,00/PZ  
ruggine



angolare elemento "L"  
30x30x5 cm 12"x12"x2" 117,59/PZ  
ruggine

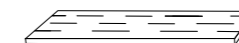

griglia  
20x61,0 cm 8"x24" R R 117,59/PZ  
ruggine



angolo SX  
griglia angolo 20x61,0 cm 8"x24" R R 256,17/coppia  
ruggine

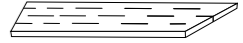

angolo DX  
griglia angolo 20x61,0 cm 8"x24" R R 256,17/coppia  
ruggine



round lineare  
30x61,5 cm 12"x24" 100,00/PZ  
ruggine

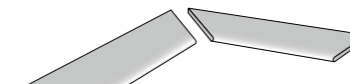

angolo SX  
angolo DX  
round angolare 30x61,5 cm 12"x24" 234,57/coppia  
ruggine



angolo SX  
angolo bordo toro 30x61,5 cm 12"x24" 145,06/PZ  
ruggine



angolo DX  
angolo bordo toro 30x61,5 cm 12"x24" 145,06/PZ  
ruggine

Note - Notes - Notes - Anmerkungen

I pezzi speciali FP2 vengono venduti al pezzo e solo su ordinazione (tempo minimo di consegna 20 gg lavorativi dall'ordine).  
The special pieces FP2 are sold by piece and only on request (minimum delivery time 20 working days from date of order).  
Les pièces spéciales FP2 sont vendus à la pièce et uniquement sur commande (délai minimum de livraison 20 jours ouvrés à partir de la commande).  
Spezial Teile FP2 sind pro Stück verkauft und nur auf Bestellungen produziert. (Lieferzeiten mindesten 20 arbeitstage ab Auftragbestätigung)

# DECAPÉ



Grès porcellanato smaltato  
 Glazed porcelain stoneware . Grès cérame émaillé . Glasiertes feinsteinzeug



technical project



NOCE FP2 | 40x122,6 cm RS\_16"x48" RS



# FP2 DECAPÉ

Grès porcellanato smaltato  
 Glazed porcelain stoneware  
 Grès cérame émaillé  
 Glasiertes feinsteinzeug



RS Rettificato/Strutturato - Rectified/Textured

FP2  
 RS

40x122,6 cm RS . 16"x48" RS

Per la disponibilità articolo: [www.tuscaniagres.it](http://www.tuscaniagres.it)  
 digitando il codice web segnalato a lato dei formati.  
 For the item's availability: [www.tuscaniagres.it](http://www.tuscaniagres.it)  
 type the web code reported next to the sizes.  
 Pour vérifier la disponibilité de l'article: [www.tuscaniagres.it](http://www.tuscaniagres.it)  
 en saisissant le code web indiqué à côté des formats.  
 Für die Artikelverfügbarkeit: [www.tuscaniagres.it](http://www.tuscaniagres.it)  
 web code eingeben, an der Seite von Formaten angedeutet.

miele



20 mm

L6U1 | 40x122,6 cm 16"x48" FP2

RS 72,54

noce



20 mm

L6U2 | 40x122,6 cm 16"x48" FP2

RS 72,54

## FP2 pezzi speciali - special pieces - pièces spéciales - formteile

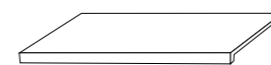

elemento "L"  
 40x122,6x5 cm 16"x48"x2" **361,12/PZ**  
 miele \_\_\_\_\_  
 noce \_\_\_\_\_

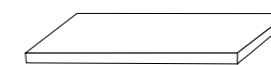

angolare elemento "L"  
 40x122,6x5 cm 16"x48"x2" **441,36/PZ**  
 miele \_\_\_\_\_  
 noce \_\_\_\_\_

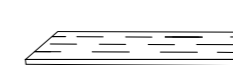

griglia  
 20x61 cm 8"x24" R **200,62/PZ**  
 miele \_\_\_\_\_  
 noce \_\_\_\_\_



angolo SX  
 griglia angolo  
 20x61 cm 8"x24" R **441,36/coppia**  
 miele \_\_\_\_\_  
 noce \_\_\_\_\_

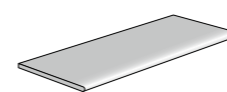
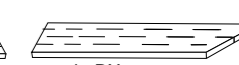

round lineare  
 40x122,6 cm 16"x48" **317,91/PZ**  
 miele \_\_\_\_\_  
 noce \_\_\_\_\_

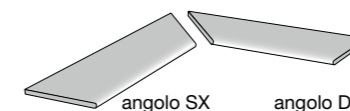

round angolare  
 40x122,6 cm 16"x48" **682,10/coppia**  
 miele \_\_\_\_\_  
 noce \_\_\_\_\_

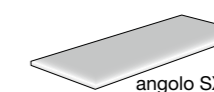

angolo bordo toro  
 40x122,6 cm 16"x48" **361,12/PZ**  
 miele \_\_\_\_\_  
 noce \_\_\_\_\_

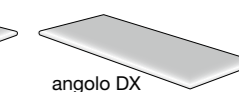

angolo DX  
**361,12/PZ**  
 miele \_\_\_\_\_  
 noce \_\_\_\_\_

Note - Notes - Notes - Anmerkungen

I pezzi speciali FP2 vengono venduti al pezzo e solo su ordinazione (tempo minimo di consegna 20 gg lavorativi dall'ordine)  
 The special pieces FP2 are sold by piece and only on request (minimum delivery time 20 working days from date of order).  
 Les pièces spéciales FP2 sont vendus à la pièce et uniquement sur commande (délai minimum de livraison 20 jours ouvrés à partir de la commande).  
 Spezial Teile FP2 sind pro Stück verkauft und nur auf Bestellungen produziert. (Lieferzeiten mindesten 20 arbeitstage ab Auftragbestätigung)



# FJORD



Grès porcellanato smaltato  
 Glazed porcelain stoneware . Grès cérame émaillé . Glasiertes feinsteinzeug



technical project



HONNING FP2 | 40x122,6 cm RS\_16"x48" RS



# FP2 FJORD

**FP2**  
**RS**  
 40x122,6 cm RS . 16"x48" RS

Per la disponibilità articolo: [www.tuscaniagres.it](http://www.tuscaniagres.it)  
 digitando il codice web segnalato a lato dei formati.  
 For the item's availability: [www.tuscaniagres.it](http://www.tuscaniagres.it)  
 type the web code reported next to the sizes.  
 Pour vérifier la disponibilité de l'article: [www.tuscaniagres.it](http://www.tuscaniagres.it)  
 en saisissant le code web indiqué à coté des formats.  
 Für die Artikelverfügbarkeit: [www.tuscaniagres.it](http://www.tuscaniagres.it)  
 web code eingeben, an der Seite von Formaten angedeutet.

Grès porcellanato smaltato  
 Glazed porcelain stoneware  
 Grès cérame émaillé  
 Glasiertes feinsteinzeug



**RS** Rettificato/Strutturato -  
 Rectified/Textured

honning



L7U1 | 40x122,6 cm 16"x48" FP2



**RS** 72,54

gra



L7U0 | 40x122,6 cm 16"x48" FP2



**RS** 72,54

## FP2 pezzi speciali - special pieces - pièces spéciales - formteile

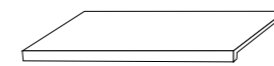

elemento "L"  
 40x122,6x5 cm 16"x48"x2" **361,12/PZ**  
 honning \_\_\_\_\_  
 gra \_\_\_\_\_

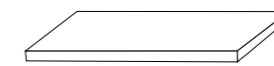

angolare elemento "L"  
 40x122,6x5 cm 16"x48"x2" **441,36/PZ**  
 honning \_\_\_\_\_  
 gra \_\_\_\_\_

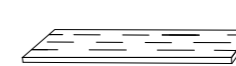

griglia  
 20x61 cm 8"x24" R **200,62/PZ**  
 honning \_\_\_\_\_  
 gra \_\_\_\_\_

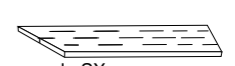

angolo SX  
 griglia angolo  
 20x61 cm 8"x24" R **441,36/coppia**  
 honning \_\_\_\_\_  
 gra \_\_\_\_\_

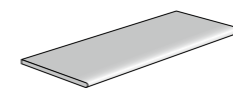
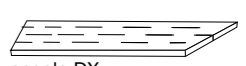

round lineare  
 40x122,6 cm 16"x48" **317,91/PZ**  
 honning \_\_\_\_\_  
 gra \_\_\_\_\_

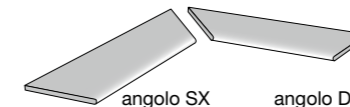

angolo SX      angolo DX  
 round angolare  
 40x122,6 cm 16"x48" **682,10/coppia**  
 honning \_\_\_\_\_  
 gra \_\_\_\_\_

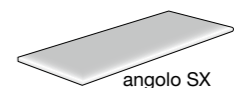

angolo SX      angolo DX  
 angolo bordo toro  
 40x122,6 cm 16"x48" **361,12/PZ**  
 honning \_\_\_\_\_  
 gra \_\_\_\_\_

Note - Notes - Notes - Anmerkungen

I pezzi speciali FP2 vengono venduti al pezzo e solo su ordinazione (tempo minimo di consegna 20 gg lavorativi dall'ordine)  
 The special pieces FP2 are sold by piece and only on request (minimum delivery time 20 working days from date of order).  
 Les pièces spéciales FP2 sont vendus à la pièce et uniquement sur commande (délai minimum de livraison 20 jours ouvrés à partir de la commande).  
 Spezial Teile FP2 sind pro Stück verkauft und nur auf Bestellungen produziert. (Lieferzeiten mindesten 20 arbeitstage ab Auftragbestätigung)

# NORTH WIND

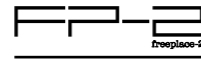

Grès porcellanato smaltato  
Glazed porcelain stoneware . Grès cérame émaillé . Glasiertes feinsteinzeug



technical project



GREY FP2 | 40x122,6 cm RS\_16"x48" RS



# FP2 NORTH WIND



40x122,6 cm RS . 16"x48" RS

Per la disponibilità articolo: [www.tuscaniagres.it](http://www.tuscaniagres.it) digitando il codice web segnalato a lato dei formati.  
For the item's availability: [www.tuscaniagres.it](http://www.tuscaniagres.it) type the web code reported next to the sizes.  
Pour vérifier la disponibilité de l'article: [www.tuscaniagres.it](http://www.tuscaniagres.it) en saisissant le code web indiqué à coté des formats.  
Für die Artikelverfügbarkeit: [www.tuscaniagres.it](http://www.tuscaniagres.it) web code eingeben, an der Seite von Formaten angedeutet.

Grès porcellanato smaltato  
Glazed porcelain stoneware  
Grès cérame émaillé  
Glasiertes feinsteinzeug



RS Rettificato/Strutturato - Rectified/Textured

grey



L7U8 | 40x122,6 cm 16"x48" FP2

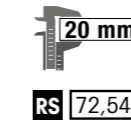

brown



L7U7 | 40x122,6 cm 16"x48" FP2

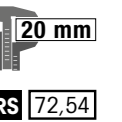

melange



L7U9 | 40x122,6 cm 16"x48" FP2

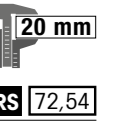

FP2 pezzi speciali - special pieces - pièces spéciales - formteile

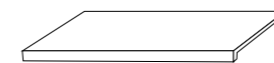

elemento "L"  
40x122,6x5 cm 16"x48"x2" **361,12/PZ**  
grey  
brown  
melange

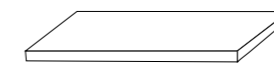

angolare elemento "L"  
40x122,6x5 cm 16"x48"x2" **441,36/PZ**  
grey  
brown  
melange

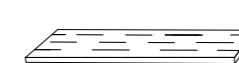

griglia  
20x61 cm 8"x24" R **200,62/PZ**  
grey  
brown  
melange



angolo SX  
griglia angolo  
20x61 cm 8"x24" R **441,36/coppia**  
grey  
brown  
melange

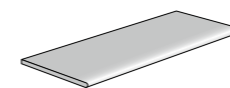
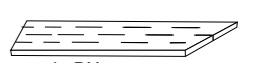

round lineare  
40x122,6 cm 16"x48" **317,91/PZ**  
grey  
brown  
melange

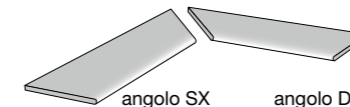

angolo SX  
angolo DX  
round angolare  
40x122,6 cm 16"x48" **682,10/coppia**  
grey  
brown  
melange

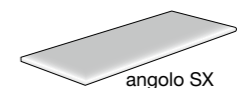

angolo SX  
angolo DX  
angolo bordo toro  
40x122,6 cm 16"x48" **361,12/PZ**  
grey  
brown  
melange

Note - Notes - Notes - Anmerkungen  
I pezzi speciali FP2 vengono venduti al pezzo e solo su ordinazione (tempo minimo di consegna 20 gg lavorativi dall'ordine)  
The special pieces FP2 are sold by piece and only on request (minimum delivery time 20 working days from date of order).  
Les pièces spéciales FP2 sont vendus à la pièce et uniquement sur commande (délai minimum de livraison 20 jours ouvrés à partir de la commande).  
Spezial Teile FP2 sind pro Stück verkauft und nur auf Bestellungen produziert. (Lieferzeiten mindesten 20 arbeitstage ab Auftragbestätigung)

# THUNDERWOOD

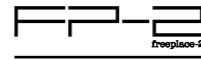

Grès porcellanato smaltato  
Glazed porcelain stoneware . Grès cérame émaillé . Glasiertes feinsteinzeug



technical project



SANDSTORM FP2 | 40x122,6 cm RS\_16"x48" RS



# FP2 THUNDERWOOD



40x122,6 cm RS . 16"x48" RS

Per la disponibilità articolo: [www.tuscaniagres.it](http://www.tuscaniagres.it)  
digitando il codice web segnalato a lato dei formati.  
For the item's availability: [www.tuscaniagres.it](http://www.tuscaniagres.it)  
type the web code reported next to the sizes.  
Pour vérifier la disponibilité de l'article: [www.tuscaniagres.it](http://www.tuscaniagres.it)  
en saisissant le code web indiqué à côté des formats.  
Für die Artikelverfügbarkeit: [www.tuscaniagres.it](http://www.tuscaniagres.it)  
web code eingeben, an der Seite von Formaten angedeutet.

Grès porcellanato smaltato  
Glazed porcelain stoneware  
Grès cérame émaillé  
Glasiertes feinsteinzeug



V4

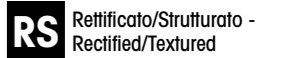

thunderstruck



L2W3 | 40x122,6 cm 16"x48" FP2

RS 72,54

sandstorm



L2W2 | 40x122,6 cm 16"x48" FP2

RS 72,54

FP2 pezzi speciali - special pieces - pièces spéciales - formteile

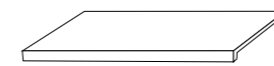

elemento "L"  
40x122,6x5 cm 16"x48"x2" **361,12/PZ**  
sandstorm  
thunderstruck

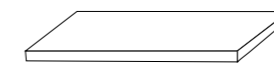

angolare elemento "L"  
40x122,6x5 cm 16"x48"x2" **441,36/PZ**  
sandstorm  
thunderstruck

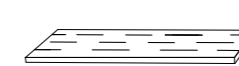

griglia  
20x61 cm 8"x24" R **200,62/PZ**  
sandstorm  
thunderstruck

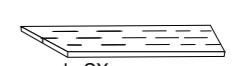

angolo SX  
griglia angolo  
20x61 cm 8"x24" R **441,36/coppia**  
sandstorm  
thunderstruck

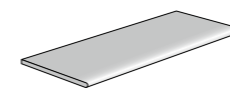
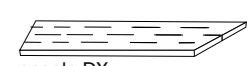

round lineare  
40x122,6 cm 16"x48" **317,91/PZ**  
sandstorm  
thunderstruck

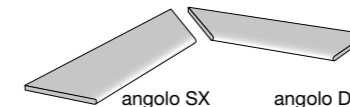

angolo SX      angolo DX  
round angolare  
40x122,6 cm 16"x48" **682,10/coppia**  
sandstorm  
thunderstruck

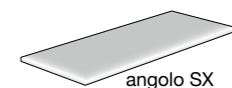

angolo bordo toro  
40x122,6 cm 16"x48" **361,12/PZ**  
sandstorm  
thunderstruck

Note - Notes - Notes - Anmerkungen

I pezzi speciali FP2 vengono venduti al pezzo e solo su ordinazione (tempo minimo di consegna 20 gg lavorativi dall'ordine).  
The special pieces FP2 are sold by piece and only on request (minimum delivery time 20 working days from date of order).  
Les pièces spéciales FP2 sont vendus à la pièce et uniquement sur commande (délai minimum de livraison 20 jours ouvrés à partir de la commande).  
Spezial Teile FP2 sind pro Stück verkauft und nur auf Bestellungen produziert. (Lieferzeiten mindesten 20 arbeitstage ab Auftragbestätigung)

# wall

## dress the wall

### Tuscania: i rivestimenti

*Un esordio all'insegna dell'eleganza e della raffinatezza,  
quello di Tuscania nel mondo dei rivestimenti.*

*Senza escludere la modernità e la versatilità di una linea classica e  
allo stesso tempo innovativa.*

*Le tonalità basiche di bianchi, grigi e beige sono movimentate dalle tessere dei mosaici,  
anche originalmente disposte a nido d'ape; delicati decori con tonalità  
che spaziano dal grigio-blu al giallo-oro impreziosiscono superfici sia materiche sia lucide.*

*Un mondo che incanta.*

### Tuscania: wall tiles

*A new beginning for tuscania in the wall tiles word in the sign of elegance and  
sophistication without keeping out modernity and versatility.*

*The basic shades of white, grey and beige are animated by eccentric and original mosaics,  
patchworks and decors with both shiny and matt surfaces.*

### Tuscania et le monde des faiences

*Un nouveau chic et charmant debut pour Tuscania dans le monde des faiences.*

*Un style classique qui se présente au meme temps polyvalente, éclectique et innovant.*

*Les nuances basiques du gris, beige et blanc viennent animées par d'excentriques et  
originaux mosaïques et décors enrichis de surfaces soit mattes que brillantes.*

### Tuscania die Wandfliesen

*Ein Beginn von Tuscania im Wandbereich mit Eleganz und Verfeinerung, ohne die  
Modernität und die Vielseitigkeit einer klassischen und innovativen Linie auszuschließen.*

*Die weißen, grauen und beige Farbtöne werden von Mosaik ergänzt,  
die auch in Wabestruktur angeboten werden.*

*Feine Dekore mit grau-blau bis gelb-gold Farbtönen für matt und glänzende Oberflächen.*

*Eine Welt, die verzaubert!*



wall: indice per formato  
format index . index des formats . formateverzeichnis

TUSCANIA ceramiche	serie . serie . gamme . serien pagina . page	32,5x32,5 cm 13"x13"	30x30 cm 12"x12"	25x60 cm . 10"x24"	20x50 cm 8"x20"	20x20 cm 8"x8"	7,5x30 cm 3"x12"	pavimento coordinato matching floor tiles carrelage sol coordonnées koordinierte bodenfiesen
beton wall	390							
decapé wall	374							
jamaica	394							
level wall	382							
manhattan	410							
mini mosaico	418							
nido d'ape	418							
north wind wall	378							
sardegna 20x20	402							
shiny marble	398							
victoria	386							



# DECAPÉ

*Bicottura tradizionale*  
Traditional double fired - Traditionnelle double feue - Zweibrandfliesen

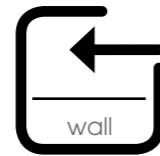

rivestimenti  
wall tiles  
faïences  
wandfliesen



pavimento coordinato - matching floor tiles - carrelage sol coordonnées - koordinierte bodenfliesen: **DECAPÉ** - pag. 222

*Grès porcellanato smaltato*  
Glazed porcelain stoneware - Grès cérame émaillé - Glasiertes Feinsteinzeug

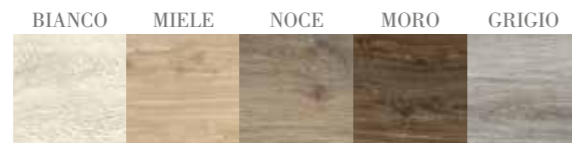

*Una pratica decorativa antica per un prodotto dalle valenze moderne.  
Ovvero una nuova interpretazione delle essenze del legno naturale applicata al prodotto ceramico.  
L'effetto superficiale "Decapé" è stato studiato per trasmettere  
armonia e calore alle superfici abitative del terzo millennio.*

*An ancient decorative technique for a product with a modern style.  
A new interpretation of the natural wood essences applied to the ceramic product.  
The "Decapé" surface effect was designed to give harmony and warmth  
to living spaces in the third millennium.*

*Une très ancienne pratique décorative, pour un produit extrêmement actuel.  
C'est-à-dire une nouvelle interprétation des essences du bois naturel  
appliquée au produit céramique.*

*Le rendu de la finition "Decapé" a été expressément étudié pour transmettre  
harmonie et chaleur aux surfaces des habitations du troisième millénaire.*

*Eine antike dekorative Verarbeitung für ein Produkt mit modernen Aspekten.  
Beziehungweise eine neue Interpretation der Essenzen des natürlichen Holzes,  
das dem Keramikprodukt verliehen wird.*

*Der Oberflächeneffekt "Decapé" wurde entworfen, um den Wohnflächen  
des dritten Jahrtausends Harmonie und Wärme zu schenken.*



# DECAPÉ

bicottura tradizionale .  
traditional double fired .  
traditionnelle double feue .  
zweibrandfliesen

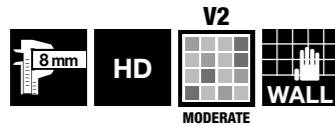

25x60 cm . 10"x24"

DECAPÉ  
Per la disponibilità articolo: [www.tuscaniagres.it](http://www.tuscaniagres.it)  
digitando il codice web segnalato a lato dei formati.  
For the item's availability: [www.tuscaniagres.it](http://www.tuscaniagres.it)  
type the web code reported next to the sizes.  
Pour vérifier la disponibilité de l'article: [www.tuscaniagres.it](http://www.tuscaniagres.it)  
en saisissant le code web indiqué à coté des formats.  
Für die Artikelverfügbarkeit: [www.tuscaniagres.it](http://www.tuscaniagres.it)  
web code eingeben, an der Seite von Formaten angedeutet.

miele



L8W4 | 25x60 cm 10"x24" 24,70

noce



L7X6 | 25x60 cm 10"x24" 24,70

bianco



L8W3 | 25x60 cm 10"x24" 24,70

grigio



L8W5 | 25x60 cm 10"x24" 24,70

decori - decors - décors - dekors

matita squadrata - 2x60 cm . 7/8"x24"  13,86/PZ

miele



noce



decori - decors - décors - dekors

matita squadrata - 2x60 cm . 7/8"x24"  13,86/PZ

bianco



grigio



mosaico mix warm - 25x60 cm 10"x24"



L7X8 | 25x60 cm 10"x24"  27,77/MQ

mosaico mix cold - 25x60 cm 10"x24"



L7X7 | 25x60 cm 10"x24"  27,77/MQ

pavimento coordinato - matching floor tiles - carrelage sol coordonné - koordinierte bodenfliessen: **DECAPÉ** - pag. 222

bianco



miele



noce



moro



grigio



# NORTH WIND

*Bicottura tradizionale*  
Traditional double fired - Traditionnelle double feue - Zweibrandfliesen

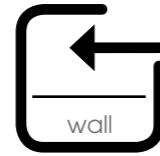

*rivestimenti*  
wall tiles  
faïences  
wandfliesen



pavimento coordinato - matching floor tiles - carrelage sol coordonné - koordinierte bodenfliesen: NORTH WIND - pag. 254

*Grès porcellanato smaltato*  
Glazed porcelain stoneware . Grès cérame émaillé . Glasiertes Feinsteinzeug



*Questa serie crea con l'ambiente un rapporto emozionale  
in quanto basata sulla capacità evocativa delle forme del legno.  
Riporta all'interno della casa la voglia di vivere in sintonia con la natura.*

*This series creates an emotional bond with its setting,  
based on the evocative nature of the forms of wood.  
It brings the desire to live in harmony with nature into the home.*

*Cette série crée avec l'environnement un rapport émotionnel dans la  
mesure où elle repose sur la capacité évocatrice des formes du bois.  
Elle transporte au sein de la maison l'envie de vivre  
en harmonie avec la nature.*

*Diese Serie stellt eine emotionale Beziehung mit der Umwelt her,  
da sie auf der besonderen Ausdrucksstärke von Holzformen beruht.  
Es bringt in unser Zuhause den Wunsch zurück,  
im Einklang mit der Natur zu leben.*



# NORTH WIND

bicottura tradizionale .  
traditional double fired .  
traditionnelle double feue .  
zweibrandfliesen

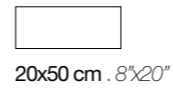

NORTH WIND

Per la disponibilità articolo: [www.tuscaniagres.it](http://www.tuscaniagres.it)  
digitando il codice web segnalato a lato dei formati.  
For the item's availability: [www.tuscaniagres.it](http://www.tuscaniagres.it)  
type the web code reported next to the sizes.  
Pour vérifier la disponibilité de l'article: [www.tuscaniagres.it](http://www.tuscaniagres.it)  
en saisissant le code web indiqué à coté des formats.  
Für die Artikelverfügbarkeit: [www.tuscaniagres.it](http://www.tuscaniagres.it)  
web code eingeben, an der Seite von Formaten angedeutet.

white



**I3Z6** | 20x50 cm 8"x20" | **22,52**

grey



**I3Z3** | 20x50 cm 8"x20" | **22,52**

ivory



**I3Z4** | 20x50 cm 8"x20" | **22,52**

oak



**I3Z5** | 20x50 cm 8"x20" | **22,52**

move - 20x50 cm 8"x20"

move white



**I4Z5** | 20x50 cm 8"x20" | **25,60/MQ**

move grey



**I4Z3** | 20x50 cm 8"x20" | **25,60/MQ**

move - 20x50 cm 8"x20"

move ivory



**I4Z4** | 20x50 cm 8"x20" | **25,60/MQ**

move oak



**I4Z6** | 20x50 cm 8"x20" | **25,60/MQ**

white



muretto 3D - 20x50 cm 8"x20"

cold



20x50 cm 8"x20" | **25,60/MQ**

grey



listello muretto 3D - 22

4,5x50 cm 1 7/8"x20"

cold



**9,26/PZ**

decori - decors - décors - dekors

matita - 2x50 cm . 7/8"x20" 22 **9,26/PZ**

ivory



muretto 3D - 20x50 cm 8"x20"

warm



20x50 cm 8"x20" | **25,60/MQ**

oak



listello muretto 3D - 22

4,5x50 cm 1 7/8"x20"

warm



**9,26/PZ**

pavimento coordinato - matching floor tiles - carrelage sol coordonnées - koordinierte bodenfliesen: **NORTH WIND** - pag. 254

ivory



grey



oak



brown



melange





# LEVEL

*Bicottura tradizionale*  
*Traditional double fired - Traditionnelle double feue - Zweibrandfliesen*

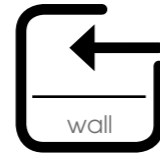

*rivestimenti*  
*wall tiles*  
*faiences*  
*wandfliesen*



pavimento coordinato - matching floor tiles - carrelage sol coordonné - koordinierte bodenfliesen: **LEVEL - pag. 68**

*Grès porcellanato impasto colorato*  
*Color body porcelain stoneware . Grès cérame coloré dans la masse . Durchgefärbtes feinsteinzeug*



*Un fondo ardesia impreziosito da nuance e striature superficiali tono su tono.*  
*Graffiti multiformi, scritte metropolitane, numeri e timbri affiorano*  
*con leggera delicatezza dai decori.*

*Un materiale metropolitano per eccellenza che trasmette creatività e*  
*dinamismo ai moderni spazi abitativi.*

*A slate background embellished by nuances and tone-on-tone surface streaks.*  
*Multifaceted graffiti, metropolitan writings,*  
*numbers and stamps emerge delicately from the decorations.*

*An excellent metropolitan material that adds creativity and dynamism to modern living spaces.*

*Un fond ardoise enrichi de nuances et de jaspures superficielles ton sur ton.*  
*Multiformité des graffitis, urbanité des inscriptions, chiffres et*  
*tampons se montrent presque avec réserve sur les décors.*  
*Urbanité d'un matériau qui transmet aux habitations modernes*  
*autant de créativité que de dynamisme.*

*Ein schiefergrauer Untergrund, der mit Nuancen und*  
*Ton-auf-Ton – Oberflächenstreifen aufgewertet ist.*  
*Mehrförmige Graffiti, metropolitane Beschriftungen, Nummern und*  
*Einprägungen erscheinen mit der leichten Sanftheit der Dekorationen.*  
*Ein absolut metropolitanes Material, das den modernen*  
*Wohnbereichen Kreativität und Dynamismus verleiht.*



# LEVEL

bicottura tradizionale .  
traditional double fired .  
traditionnelle double feue .  
zweibrandfliesen



LEVEL

Per la disponibilità articolo: [www.tuscaniagres.it](http://www.tuscaniagres.it)  
digitando il codice web segnalato a lato dei formati.  
For the item's availability: [www.tuscaniagres.it](http://www.tuscaniagres.it)  
type the web code reported next to the sizes.  
Pour vérifier la disponibilité de l'article: [www.tuscaniagres.it](http://www.tuscaniagres.it)  
en saisissant le code web indiqué à coté des formats.  
Für die Artikelverfügbarkeit: [www.tuscaniagres.it](http://www.tuscaniagres.it)  
web code eingeben, an der Seite von Formaten angedeutet.

white



J105 | 20x50 cm 8"x20" | 22,52

decori - decors - décors - dekors

matita - 2x50 cm . 7/8"x20" | 9,26/PZ  
white



mosaico level

20x50 cm 8"x20"



20x50 cm 8"x20" | mix | 25,60/MQ

decoro - 20x50 cm 8"x20"

white

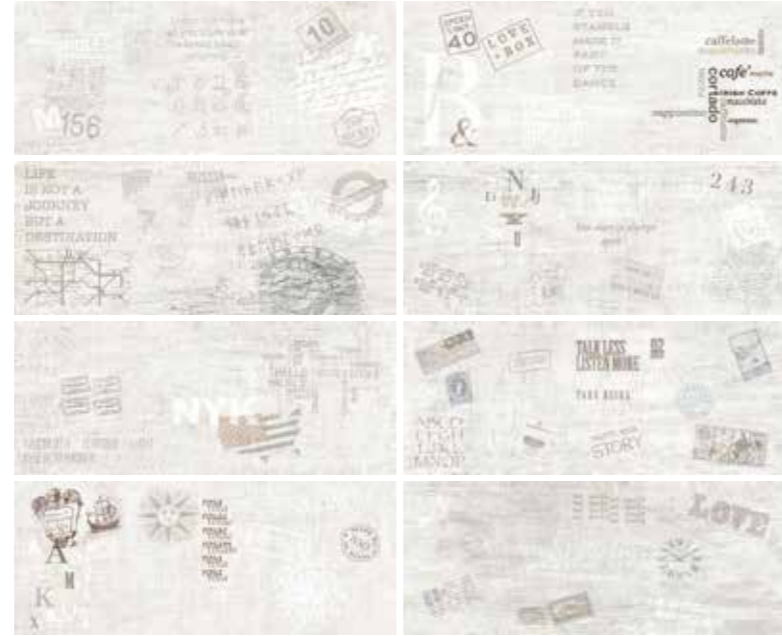

J205 | 20x50 cm 8"x20" | mix | 25,60/MQ

grey

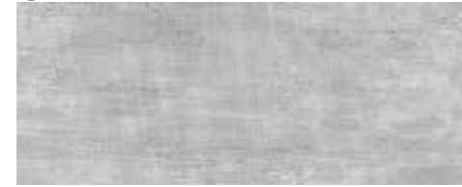

J106 | 20x50 cm 8"x20" | 22,52

decori - decors - décors - dekors

matita - 2x50 cm . 7/8"x20" | 9,26/PZ  
grey



decoro - 20x50 cm 8"x20"

grey

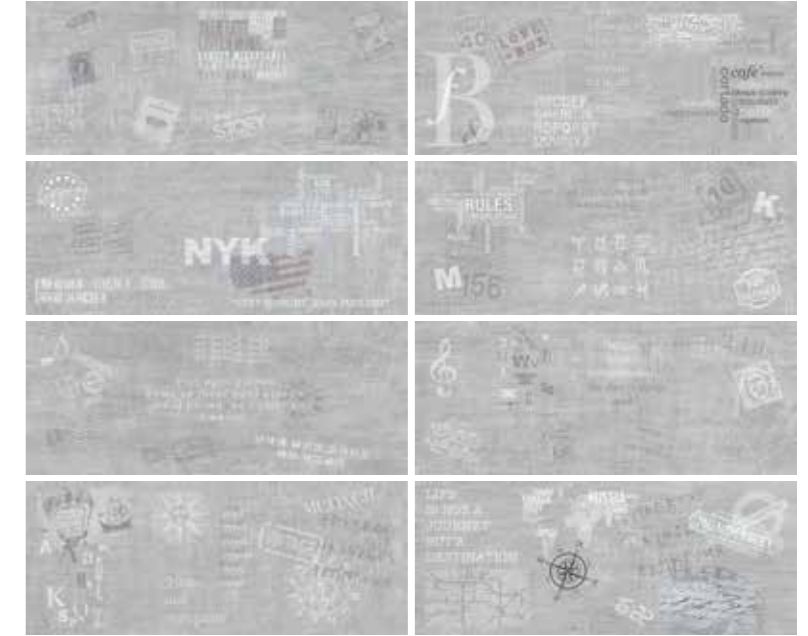

J204 | 20x50 cm 8"x20" | mix | 25,60/MQ

pavimento coordinato - matching floor tiles - carrelage sol coordonnées - koordinierte bodenfriesen: LEVEL - pag. 68

white



grey



dark grey



anthracite



# VICTORIA

*Bicottura tradizionale*  
Traditional double fired - Traditionnelle double feue - Zweibrandfliesen

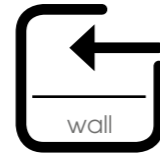

*rivestimenti*  
wall tiles  
faïences  
wandfliesen



pavimento coordinato - matching floor tiles - carrelage sol coordonnées - koordinierte bodenfliesen: VICTORIA

*Grès porcellanato smaltato*  
Glazed porcelain stoneware . Grès cérame émaillé . Glasiertes feinsteinzeug



## *Il trionfo del Patchwork.*

*Uno stile che si è sviluppato nei secoli scorsi Oltremare e che ha preso velocemente piede anche in Europa.*

*Una proposta che completa un catalogo già molto ricco di rivestimenti e che conferma l'attenzione e l'impegno del gruppo ad offrire una gamma di prodotti giusti per ogni richiesta.*

## *The triumph of Patchwork.*

*A style that developed in past centuries on the other side of the Atlantic, which quickly took hold in Europe too.*

*A proposal completing an already rich catalogue of coverings, confirming the group's attention and commitment to supplying a range of products that perfectly meet every demand.*

## *Le triomphe du Patchwork.*

*Un style qui s'est développé outre-mer lors des siècles derniers et qui a rapidement pris pied en Europe.*

*Une proposition qui complète un catalogue déjà riche en revêtements et qui confirme l'attention et l'engagement du groupe pour offrir une gamme de produits adaptés pour chaque exigence.*

*Der Triumph von Patchwork. Ein Stil, der sich in den letzten Jahrhunderten vor allem in den USA entwickelt und in Europa schnell Fuß gefasst hat.*

*Ein Vorschlag, der eine bereits sehr reichhaltiges Sortiment perfekt ergänzt und die Aufmerksamkeit und das Engagement der Gruppe bestätigt, eine Produktpalette anzubieten, die alle Wünsche erfüllt.*



# VICTORIA

bicottura tradizionale .  
traditional double fired .  
traditionnelle double feue .  
zweibrandfliesen

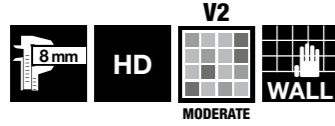

20x50 cm . 8"x20"

VICTORIA  
Per la disponibilità articolo: [www.tuscaniagres.it](http://www.tuscaniagres.it)  
digitando il codice web segnalato a lato dei formati.  
For the item's availability: [www.tuscaniagres.it](http://www.tuscaniagres.it)  
type the web code reported next to the sizes.  
Pour vérifier la disponibilité de l'article: [www.tuscaniagres.it](http://www.tuscaniagres.it)  
en saisissant le code web indiqué à coté des formats.  
Für die Artikelverfügbarkeit: [www.tuscaniagres.it](http://www.tuscaniagres.it)  
web code eingeben, an der Seite von Formaten angedeutet.

white



J6U6 | 20x50 cm 8"x20" | 22,52

sand



J8U9 | 20x50 cm 8"x20" | 22,52

taupe



J9U0 | 20x50 cm 8"x20" | 22,52

fumé



J9U1 | 20x50 cm 8"x20" | 22,52

avio



J9U2 | 20x50 cm 8"x20" | 22,52

decori - decors - décors - dekors

matita - 2x50 cm . 7/8"x20" | 9,26/PZ

white



sand



taupe



decori - decors - décors - dekors

matita - 2x50 cm . 7/8"x20" | 9,26/PZ

fumé



avio



mosaico victoria

20x50 cm R . 8"x20" R

warm



L0N2 | 20x50 cm 8"x20" | 25,60/MQ

listello mosaico victoria

3,5x50 cm 1 1/2"x20"

warm



9,26/PZ

mosaico victoria

20x50 cm R . 8"x20" R

cold



L0N1 | 20x50 cm 8"x20" | 25,60/MQ

listello mosaico victoria

3,5x50 cm 1 1/2"x20"

cold



9,26/PZ

decoro victoria

20x50 cm . 8"x20"

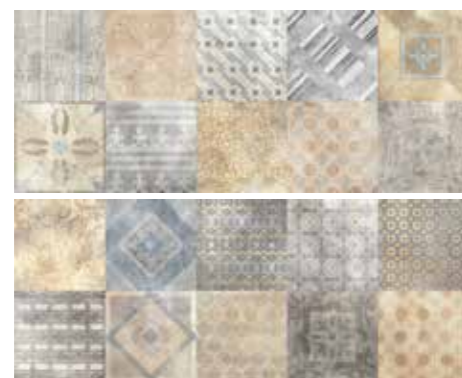

J2V5 | 20x50 cm 8"x20" | 25,60/MQ

pavimento coordinato - matching floor tiles - carrelage sol coordonnées - koordinierte bodenfliesen: VICTORIA



30,6x30,6 cm N . 12"x12" N

N Naturale - Natural

Grès porcellanato smaltato  
Glazed porcelain stoneware  
Grès cérame émaillé  
Glasiertes feinsteinzeug



taupe

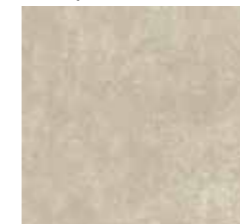

L4X3 | 30,6x30,6 cm 12"x12" | 18,50

fumé



L4X4 | 30,6x30,6 cm 12"x12" | 18,50

avio



L7X4 | 30,6x30,6 cm 12"x12" | 18,50

# BETON

*Bicottura tradizionale*  
Traditional double fired - Traditionnelle double feue - Zweibrandfliesen

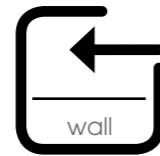

rivestimenti  
wall tiles  
faïences  
wandfliesen



pavimento coordinato - matching floor tiles - carrelage sol coordonnées - koordinierte bodenfliesen: **BETON** easy collection - pag. 320

*Grès porcellanato smaltato*  
Glazed porcelain stoneware . Grès cérame émaillé . Glasiertes feinsteinzeug



*Sintetizza la capacità dell'azienda di interpretare  
le ultime tendenze nelle superfici ceramiche.  
In questo caso l'effetto voluto è quello del cemento, attraverso  
una finitura morbida quasi vellutata ma particolarmente resistente.*

*This series sums up the ability of the company to interpret  
the latest trends in ceramic surfaces.*

*In this case, the aim is that of creating concrete through  
a soft, almost velvety yet particularly resistant finish.*

*Synthétise la capacité de l'entreprise à interpréter  
les dernières tendances relatives aux surfaces céramiques.*

*Dans ce cas, l'effet recherché est celui du béton, dans  
une finition douce presque soyeuse mais particulièrement résistante.*

*Diese Serie vereint die Fähigkeit des Unternehmens,  
die neuesten Trends bei keramischen Oberflächen zu interpretieren.  
In diesem Fall ist die gewünschte Wirkung die von Zement,  
der sich durch eine weiche, fast samtige,  
aber besonders widerstandsfähige Oberfläche auszeichnet.*

-CG\_390-



-CG\_391-

wall: GLACE e BLANC | 20x50 cm . 8"x20"  
deco BLANC | 20x50 cm . 8"x20"  
matita GLACE | 2x50 cm . 7/8"x20"  
floor: BLANC | 61,0x61,0 cm R\_24"x24" R

# BETON

bicottura tradizionale .  
traditional double fired .  
traditionnelle double feue .  
zweibrandfliesen



20x50 cm . 8"x20"

BETON  
Per la disponibilità articolo: [www.tuscaniagres.it](http://www.tuscaniagres.it)  
digitando il codice web segnalato a lato dei formati.  
For the item's availability: [www.tuscaniagres.it](http://www.tuscaniagres.it)  
type the web code reported next to the sizes.  
Pour vérifier la disponibilité de l'article: [www.tuscaniagres.it](http://www.tuscaniagres.it)  
en saisissant le code web indiqué à coté des formats.  
Für die Artikelverfügbarkeit: [www.tuscaniagres.it](http://www.tuscaniagres.it)  
web code eingeben, an der Seite von Formaten angedeutet.

taupe



L3S9 | 20x50 cm 8"x20" 22,52

blanc



L3S8 | 20x50 cm 8"x20" 22,52

glace



L4S0 | 20x50 cm 8"x20" 22,52

decori - decors - décors - dekors

matita - 2x50 cm . 7/8"x20" 9,26/PZ

taupe



blanc



decori - decors - décors - dekors

matita - 2x50 cm . 7/8"x20" 9,26/PZ

glace



decoro - 20x50 cm 8"x20"

taupe



L4S2 | 20x50 cm 8"x20" 25,60/MQ

blanc



L4S1 | 20x50 cm 8"x20" 25,60/MQ

mosaico beton - 20x50 cm 8"x20"



L5S7 | 20x50 cm 8"x20" 25,60/MQ

pavimento coordinato - matching floor tiles - carrelage sol coordonnées - koordinierte bodenfliesten: **BETON** easy collection - pag. 320

blanc



gris



taupe



marron

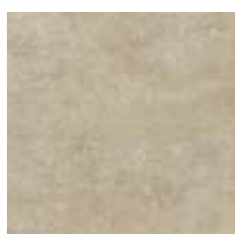

# JAMAICA

*Bicottura tradizionale*  
*Traditional double fired - Traditionnelle double feue - Zweibrandfliesen*

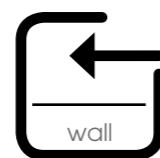

*rivestimenti*  
*wall tiles*  
*faiences*  
*wandfliesen*



*Cinque colori di fondo mossi da una pennellatura leggera ed uniforme stanno alla base di un progetto decorativo studiato in pieno stile Patchwork. Uno stile giovane ed attuale in perfetta armonia con il vivere quotidiano.*

*Five base colours moved by light, uniform brush strokes are the base of this decorative project designed in full Patchwork style. A young, current style, in perfect harmony with everyday living.*

*Cinq couleurs de fond remuées par un coup de pinceau léger et uniforme sont à la base d'un projet de décoration réalisé en parfait style Patchwork. Un style jeune et actuel en parfaite harmonie avec la vie quotidienne.*

*Fünf Hintergrundfarben mit leichten, gleichmäßigen Pinselstrichen bilden die Grundlage für ein Dekorprojekt in Patchwork-Stil. Ein junger und zeitgemäßer Stil in perfekter Harmonie mit dem Alltagsleben.*



# JAMAICA

bicottura tradizionale .  
traditional double fired .  
traditionelle double feue .  
zweibrandfliesen

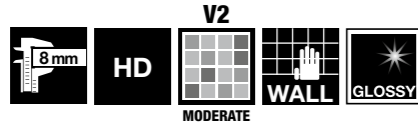

20x50 cm . 8"x20"

bianco glossy

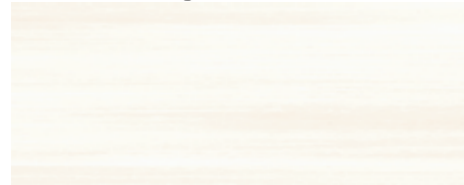

J5E5 | 20x50 cm 8"x20" | 22,52

tramonto glossy

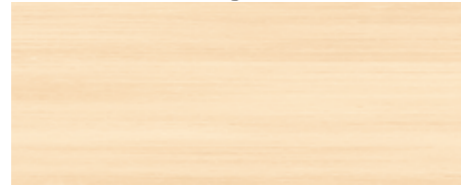

J5E9 | 20x50 cm 8"x20" | 22,52

taupe glossy



J5E8 | 20x50 cm 8"x20" | 22,52

palma glossy



J5E7 | 20x50 cm 8"x20" | 22,52

mare glossy



J5E6 | 20x50 cm 8"x20" | 22,52

decori - decors - décors - dekors

matita glossy- 2x50 cm . 7/8"x20"

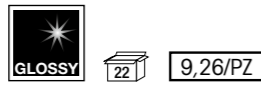

bianco glossy



tramonto glossy



taupe glossy



matita glossy- 2x50 cm . 7/8"x20"



palma glossy



mare glossy



\*decoro jamaica glossy - 20x50 cm 8"x20"



tramonto jamaica glossy



J7U1 | 20x50 cm 8"x20" | mix | 25,60/MQ

taupe jamaica glossy

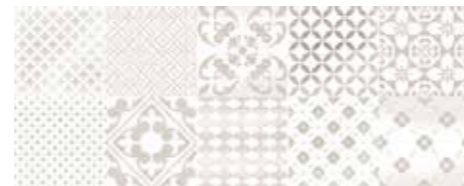

J9P3 | 20x50 cm 8"x20" | mix | 25,60/MQ

\*decoro jamaica glossy - 20x50 cm 8"x20"



palma jamaica glossy



J7U0 | 20x50 cm 8"x20" | mix | 25,60/MQ

mare jamaica glossy



J6U9 | 20x50 cm 8"x20" | mix | 25,60/MQ

JAMAICA  
Per la disponibilità articolo: [www.tuscaniagres.it](http://www.tuscaniagres.it)  
digitando il codice web segnalato a lato dei formati.  
For the item's availability: [www.tuscaniagres.it](http://www.tuscaniagres.it)  
type the web code reported next to the sizes.  
Pour vérifier la disponibilité de l'article: [www.tuscaniagres.it](http://www.tuscaniagres.it)  
en saisissant le code web indiqué à coté des formats.  
Für die Artikelverfügbarkeit: [www.tuscaniagres.it](http://www.tuscaniagres.it)  
web code eingeben, an der Seite von Formaten angedeutet.

decori - decors - décors - dekors  
\*decoro jamaica glossy

20x50 cm 8"x20"

7 soggetti diversi, miscelazione casuale,  
Disponibile in tutti i colori.

7 assorted motifs, random mix.  
Available in all colours.

7 sujets différents, mélange aleatoire,  
Disponible dans toutes les gammes de couleur.

7 verschiedene Motive, Zufallsmischung.  
In allen Farben verfügbar.





# SHINY MARBLE

*Bicottura tradizionale*  
Traditional double fired - Traditionnelle double feue - Zweibrandfliesen

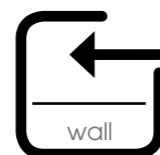

*rivestimenti*  
wall tiles  
faïences  
wandfliesen



pavimento coordinato - matching floor tiles - carrelage sol coordonné - koordinierte bodenfliesen: SHINY MARBLE

*Grès porcellanato smaltato*  
Glazed porcelain stoneware . Grès cérame émaillé . Glasiertes feinsteinzeug



*Sintesi classica per un progetto che esalta tutta la naturalezza ed il fascino dei marmi, riportandoci contemporaneamente ai fasti tradizionali dei Travertini Imperiali.*

*Inoltre, alcuni moduli incisi secondo forme geometriche regolari, disegnano e frammentano le superfici seguendo una nuova rappresentazione estetica.*

*Classic synthesis for a project that exalts all the naturalness and charm of marble, at the same time taking us back to the traditional magnificence of the 'Travertini Imperiali'. Furthermore, some modules engraved according to regular geometric shapes design and fragment the surfaces, following a new concept of beauty.*

*Synthèse classique pour un projet qui met en valeur tout le naturel et le charme des marbres, nous reportant par la même occasion aux fastes traditionnels des Travertins Impériaux.*

*En outre, certains des modules gravés selon des formes géométriques régulières, dessinent et fragmentent les surfaces en adoptant une nouvelle représentation esthétique.*

*Eine klassische Synthese für ein Projekt, das die ganze Natürlichkeit und den Charme des Marmors zum Ausdruck bringt und uns gleichzeitig zur traditionellen Pracht des kaiserlichen Travertins zurückkehrt. Zusätzlich zeichnen und fragmentieren einige Module, die in regelmäßige geometrische Formen graviert sind, die Oberflächen nach einer neuen ästhetischen Darstellung.*



# SHINY MARBLE

bicottura tradizionale .  
traditional double fired .  
traditionnelle double feu .  
zweibrandfliesen



20x50 cm . 8"x20"

SHINY MARBLE  
Per la disponibilità articolo: [www.tuscaniagres.it](http://www.tuscaniagres.it)  
digitando il codice web segnalato a lato dei formati.  
For the item's availability: [www.tuscaniagres.it](http://www.tuscaniagres.it)  
type the web code reported next to the sizes.  
Pour vérifier la disponibilité de l'article: [www.tuscaniagres.it](http://www.tuscaniagres.it)  
en saisissant le code web indiqué à côté des formats.  
Für die Artikelverfügbarkeit: [www.tuscaniagres.it](http://www.tuscaniagres.it)  
web code eingeben, an der Seite von Formaten angedeutet.

wall: TRAVERTINO GRIGIO e TRAVERTINO BIANCO | 20x50 cm . 8"x20" - matita TRAVERTINO GRIGIO | 2x50 cm\_7/8"x20"  
floor: TRAVERTINO GRIGIO | 30,6x30,6 cm N\_12"x12" N

travertino almond



J0L7 | 20x50 cm 8"x20" | 22,52

travertino grigio



J0L3 | 20x50 cm 8"x20" | 22,52

travertino bianco



J2L7 | 20x50 cm 8"x20" | 22,52

decori - decors - décors - dekors

mosaico rettangolo inciso - 20x50 cm . 8"x20"

travertino almond



J0L8 | 20x50 cm 8"x20" | mix | 25,60/MQ

travertino grigio

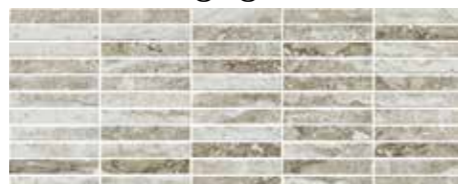

J0L4 | 20x50 cm 8"x20" | mix | 25,60/MQ

matita - 2x50 cm . 7/8"x20" | 22 | 9,26/PZ

travertino almond



travertino grigio



pavimento coordinato - matching floor tiles - carrelage sol coordonné - koordinierte bodenfliesten: SHINY MARBLE

Grès porcellanato smaltato  
Glazed porcelain stoneware  
Grès cérame émaillé  
Glasiertes Feinsteinzeug



N Naturale - Natural



30,6x30,6 cm N . 12"x12" N

travertino almond



L7X1 | 30,6x30,6 cm 12"x12" | N | 18,50

travertino grigio



L7X2 | 30,6x30,6 cm 12"x12" | N | 18,50



# SARDEGNA

*Bicottura tradizionale*  
Traditional double fired - Traditionnelle double feue - Zweibrandfliesen

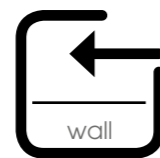

rivestimenti  
wall tiles  
faïences  
wandfliesen



*Colori di fondo dal sapore mediterraneo che ci riportano ai limpidi e trasparenti fondali marini. Minuscole tessere a volte quadrate, a volte rettangolari proposte su un formato di cm. 20x20 giocano armoniosamente con la luce per realizzare superfici ambientate di forte glamour.*

*Base colours with a Mediterranean flavour reminiscent of the clear, transparent sea beds. Tiny square and rectangular tesserae in sizes cm 20x20 play harmoniously with the light to create surfaces with a strong glamour appeal.*

*Des couleurs de fond à la saveur méditerranéenne qui nous font voyager dans les fonds marins limpides et transparents. De minuscules tesselles, parfois carrées, parfois rectangulaires, proposées sur un format de cm 20x20 jouent harmonieusement avec la lumière pour réaliser des surfaces empreintes d'une intense touche glamour.*

*Mediterrane Grundfarben, die an klare und transparente Meeresgründe erinnern. Winzige quadratische oder rechteckige Fliesen im Format 20x20 cm spielen harmonisch mit dem Licht und schaffen Flächen, die Glamour ausstrahlen.*



wall: BIANCO e SMERALDO SCURO | 20x20 cm \_8"x8"  
mosaico SMERALDO | 20x20 cm \_8"x8"  
Formella APICELLA SMERALDO | 20x20 cm \_8"x8"  
Formellina APICELLA SMERALDO | 10x20 cm \_4"x8"  
Torellone SMERALDO | 4x20 cm \_1 3/4"x8"

floor: DECAPÉ MORO | 30,5x122,6 cm R\_12"x48" R - 20,3x122,6 cm R\_8"x48" R

AZZURRO CHIARO e AZZURRO SCURO | 20x20 cm \_8"x8"  
Formella MARGHERITA AZZURRO | 20x20 cm \_8"x8"  
Formellina MARGHERITA AZZURRO | 7,5x20 cm \_3"x8"  
Torellone AZZURRO | 4x20 cm \_1<sup>3</sup>/<sub>4</sub>"x8"



-CG\_404-

VIOLA CHIARO e VIOLA SCURO | 20x20 cm \_8"x8"  
Formella MARE VIOLA | 20x20 cm \_8"x8"  
Formellina MARE VIOLA | 7,5x20 cm \_3"x8"  
Torellone VIOLA | 4x20 cm \_1<sup>3</sup>/<sub>4</sub>"x8"



-CG\_405-

# SARDEGNA

bicottura tradizionale .  
traditional double fired .  
traditionelle double feue .  
zweibrandfriesen



20x20 cm . 8"x8"

SARDEGNA  
Per la disponibilità articolo: [www.tuscaniagres.it](http://www.tuscaniagres.it)  
digitando il codice web segnalato a lato dei formati.  
For the item's availability: [www.tuscaniagres.it](http://www.tuscaniagres.it)  
type the web code reported next to the sizes.  
Pour vérifier la disponibilité de l'article: [www.tuscaniagres.it](http://www.tuscaniagres.it)  
en saisissant le code web indiqué à coté des formats.  
Für die Artikelverfügbarkeit: [www.tuscaniagres.it](http://www.tuscaniagres.it)  
web code eingeben, an der Seite von Formaten angedeutet.

bianco



J5A2 | 20x20 cm 8"x8" | 78,25

smeraldo  
chiaro



J6A6 | 20x20 cm 8"x8" | 78,25

smeraldo  
scuro



J6A7 | 20x20 cm 8"x8" | 78,25

mosaico  
smeraldo

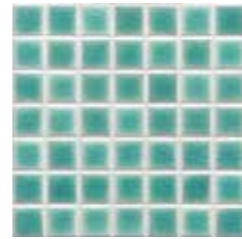

J6A8 | 20x20 cm 8"x8" | 78,25/MQ

bianco



J5A2 | 20x20 cm 8"x8" | 78,25

azzurro  
chiaro



J8A0 | 20x20 cm 8"x8" | 78,25

azzurro  
scuro



J8A1 | 20x20 cm 8"x8" | 78,25

mosaico  
azzurro

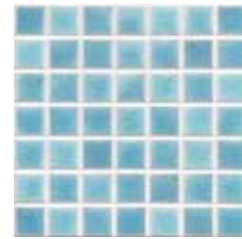

J8A2 | 20x20 cm 8"x8" | 78,25/MQ

decori - decors - décors - dekors

formella - 20x20 cm 8"x8" | 37,04/PZ

tribal  
smeraldo



mare  
smeraldo



margherita  
smeraldo



apicella  
smeraldo



decori - decors - décors - dekors

formella - 20x20 cm 8"x8" | 37,04/PZ

tribal  
azzurro



mare  
azzurro



margherita  
azzurro



apicella  
azzurro



formellina - 7,5x20 cm 3"x8" | 16,98/PZ

tribal  
smeraldo



mare  
smeraldo



margherita  
smeraldo



formellina -  
10x20 cm 4"x8" | 16,98/PZ

apicella  
smeraldo



formellina - 7,5x20 cm 3"x8" | 16,98/PZ

tribal  
azzurro



mare  
azzurro



margherita  
azzurro



formellina -  
10x20 cm 4"x8" | 16,98/PZ

apicella  
azzurro



torellone -  
4x20 cm 1 3/4"x8"

36 | 10,80/PZ

smeraldo



spigolo est.  
torellone  
smeraldo

20,06/PZ

spigolo int.  
torellone  
smeraldo

20,06/PZ

torellone -  
4x20 cm 1 3/4"x8"

36 | 10,80/PZ

azzurro



spigolo est.  
torellone  
azzurro

20,06/PZ

spigolo int.  
torellone  
azzurro

20,06/PZ



# SARDEGNA



bicottura tradizionale .  
traditional double fired .  
traditionelle double feue .  
zweibrandfriesen

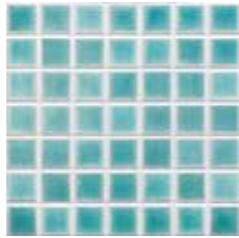

20x20 cm . 8"x8"

SARDEGNA  
Per la disponibilità articolo: [www.tuscaniagres.it](http://www.tuscaniagres.it)  
digitando il codice web segnalato a lato dei formati.  
For the item's availability: [www.tuscaniagres.it](http://www.tuscaniagres.it)  
type the web code reported next to the sizes.  
Pour vérifier la disponibilité de l'article: [www.tuscaniagres.it](http://www.tuscaniagres.it)  
en saisissant le code web indiqué à coté des formats.  
Für die Artikelverfügbarkeit: [www.tuscaniagres.it](http://www.tuscaniagres.it)  
web code eingeben, an der Seite von Formaten angedeutet.

bianco	giada chiaro	giada scuro	mosaico giada
			
J5A2   20x20 cm 8"x8"   78,25	J9A3   20x20 cm 8"x8"   78,25	J9A4   20x20 cm 8"x8"   78,25	J9A5   20x20 cm 8"x8"   78,25/MQ

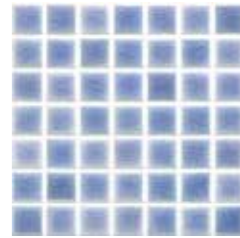
bianco	viola chiaro	viola scuro	mosaico viola
			
J5A2   20x20 cm 8"x8"   78,25	J5A3   20x20 cm 8"x8"   78,25	J5A4   20x20 cm 8"x8"   78,25	J5A5   20x20 cm 8"x8"   78,25/MQ

decori - decors - décors - dekors

formella - 20x20 cm 8"x8"  37,04/PZ

tribal giada	mare giada	margherita giada	apicella giada
			

decori - decors - décors - dekors

formella - 20x20 cm 8"x8"  37,04/PZ

tribal viola	mare viola	margherita viola	apicella viola
			

formellina - 7,5x20 cm 3"x8"  16,98/PZ

tribal giada  21	mare giada  23	margherita giada  17	apicella giada  34
			

formellina - 7,5x20 cm 3"x8"  16,98/PZ

tribal viola  21	mare viola  23	margherita viola  17	apicella viola  34
			

torellone -  
4x20 cm 1 3/4"x8"  
 10,80/PZ



spigolo est.  
torellone  
giada  20,06/PZ

spigolo int.  
torellone  
giada  20,06/PZ

torellone -  
4x20 cm 1 3/4"x8"  
 10,80/PZ



spigolo est.  
torellone  
viola  20,06/PZ

spigolo int.  
torellone  
viola  20,06/PZ

# MANHATTAN

*Monocottura atomizzata pasta bianca*

*White body single fire. Carreaux en monocuisson de pate blanche. Einmal gebrante Fliese weisse scherbe*

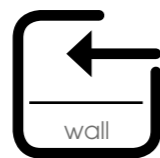

*rivestimenti  
wall tiles  
faïences  
wandfliesen*



*Una scelta originale e molto esclusiva risulta essere la nuova serie “Manhattan”.  
Listelli sorprendenti nelle tinte lucide acquerellate e sfumate, superficialmente sagomate,  
fanno rivivere calde e carismatiche suggestioni solari e mediterranee.*

*Le varianti superficiali studiate su un supporto in pasta bianca,  
ad elevato contenuto di prezioso caolino, sono tre: matt, glossy e craquelé.*

*An original, highly exclusive choice: the “Manhattan” series.  
Surprising listel tiles in glossy watercolour and nuanced shades, with shaped surfaces,  
bringing to life warm, charismatic, sunny Mediterranean ambiances.  
Three surface variants, on a white body support with a high kaolin content:  
matt, glossy and craquelé.*

*Un choix original et très exclusif correspond à la nouvelle série “Manhattan”.  
Des listels surprenants dans les teintes brillantes aquarellées et estompées, modelées en surface,  
font revivre des suggestions solaires et méditerranéennes chaudes et charismatiques.  
Les variantes superficielles réalisées sur un support en pâte blanche,  
au contenu élevé en caolin précieux, sont trois : mate, glossy et craquelée.*

*Als originelle und besonders exklusive Wahl erweist sich die neue Serie „Manhattan“.  
Überraschende Leisten in glänzenden, nuancierten Aquarellfarben, die oberflächlich geformt sind und  
warme, charismatische Anregungen von Sonne und Mittelmeer in den Sinn bringen.  
Es gibt drei auf einer weißscherbigen Basis mit hohem Gehalt an  
kostbarem Kaolin ausgearbeitete Varianten: matt, glossy und craquelé.*







GREY GLOSSY | 7,5x30 cm\_3"x12"



# MANHATTAN

monocottura atomizzata pasta bianca .  
white body single fire.  
carreaux en monocuisson de pate blanche .  
Einmal gebrante Fliese weisse scherbe



7,5x30 cm . 3"x12"

## matt

calacatta matt  L1X4   7,5x30 cm 3"x12"   52,47	white matt  L9R9   7,5x30 cm 3"x12"   52,47	grey matt  L1S0   7,5x30 cm 3"x12"   52,47	beige matt  L7S2   7,5x30 cm 3"x12"   52,47
	black matt  L7S3   7,5x30 cm 3"x12"   52,47	blue matt  L7S4   7,5x30 cm 3"x12"   52,47	tortora matt  L7S5   7,5x30 cm 3"x12"   52,47

## glossy

calacatta glossy  L1X5   7,5x30 cm 3"x12"   52,47	white glossy  L0S2   7,5x30 cm 3"x12"   52,47	grey glossy  L0S4   7,5x30 cm 3"x12"   52,47	beige glossy  L0S9   7,5x30 cm 3"x12"   52,47
	black glossy  L7S6   7,5x30 cm 3"x12"   52,47	blue glossy  L0S5   7,5x30 cm 3"x12"   52,47	tortora glossy  L0S3   7,5x30 cm 3"x12"   52,47

# MANHATTAN

Per la disponibilità articolo: [www.tuscaniagres.it](http://www.tuscaniagres.it)  
digitando il codice web segnalato a lato dei formati.  
For the item's availability: [www.tuscaniagres.it](http://www.tuscaniagres.it)  
type the web code reported next to the sizes.  
Pour vérifier la disponibilité de l'article: [www.tuscaniagres.it](http://www.tuscaniagres.it)  
en saisissant le code web indiqué à coté des formats.  
Für die Artikelverfügbarkeit: [www.tuscaniagres.it](http://www.tuscaniagres.it)  
web code eingeben, an der Seite von Formaten angedeutet.

## craquelé

bianco craquelé  L0S1   7,5x30 cm 3"x12"   83,34	taupe craquelé  L0S8   7,5x30 cm 3"x12"   83,34
azzurro craquelé  L0S7   7,5x30 cm 3"x12"   83,34	smeraldo craquelé  L0S6   7,5x30 cm 3"x12"   83,34

pezzi speciali - special pieces - pièces spéciales - formteile

manhattan quarter round - 1,2x30 cm 1/2"x12" | 12,35/PZ

calacatta matt	calacatta glossy	bianco craquelé
white matt	white glossy	taupe craquelé
grey matt	grey glossy	azzurro craquelé
blue matt	blue glossy	smeraldo craquelé
black matt	black glossy	
beige matt	beige glossy	
tortora matt	tortora glossy	

# NIDO D'APE / MINI MOSAICO

*Monocottura atomizzata pasta bianca*

*White body single fire. Carreaux en monocuisson de pate blanche. Einmal gebrante Fliese weisse scherbe*

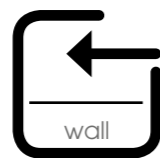

*rivestimenti  
wall tiles  
faïences  
wandfliesen*



*Fin dal passato la tecnica del mosaico ha avuto un particolare fascino nella cultura dei vari popoli. Principalmente destinata alla decorazione di pavimenti e pareti continua ad ottenere pregevoli consensi anche nelle attuali architetture. Questa proposta di sapore high-tech è il risultato di un gusto attuale spiccatamente moderno.*

*Since ancient times the mosaic technique has held a special charm for the culture of many peoples. Destined mainly for decorating floors and walls, its precious popularity continues in modern architecture. This range with a high-tech flavour is the result of a very modern taste.*

*Depuis toujours, la technique de la mosaïque a eu un charme particulier dans la culture des différents peuples. Principalement destinée à la décoration de sols et de murs, elle continue à obtenir de véritables succès dans les architectures actuelles aussi. Cette proposition au caractère high-tech est le résultat d'un goût actuel fortement moderne.*

*In den verschiedensten Kulturen in Vergangenheit und Gegenwart war die Mosaiktechnik zu Dekorzwecken äußerst beliebt. Das Mosaik ist hauptsächlich für die Dekoration von Böden und Wänden gedacht und auch für moderne Architekturlösungen sehr beliebt. Dieser Vorschlag mit Hightech-Flair ist ausgesprochen modern.*







# NIDO D'APE

monocottura atomizzata pasta bianca .  
white body single fire.  
carreaux en monocuisson de pate blanche .  
Einmal gebrante Fliese weisse scherbe

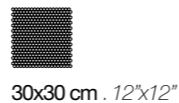
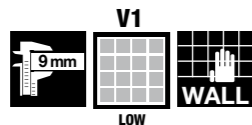

bianco



I2W4 | 30x30 12"x12" | 169,75

grigio



I2W5 | 30x30 12"x12" | 169,75

beige



I2W3 | 30x30 12"x12" | 169,75

tortora

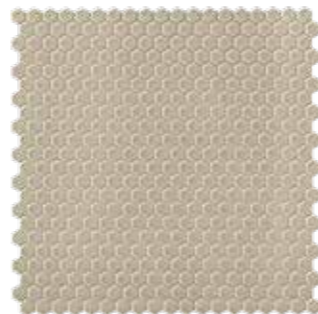

I2W6 | 30x30 12"x12" | 169,75

# MINI MOSAICO

monocottura atomizzata pasta bianca .  
white body single fire.  
carreaux en monocuisson de pate blanche .  
Einmal gebrante Fliese weisse scherbe

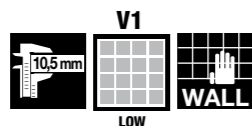

bianco

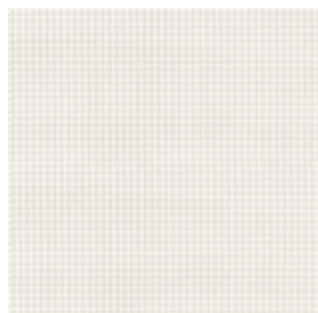

I2W0 | 32,5x32,5 13"x13" | 169,75

grigio

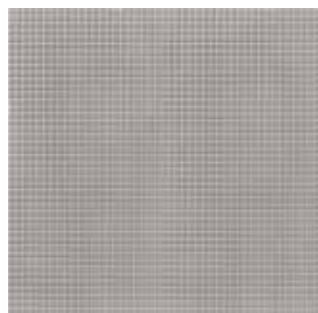

I2W1 | 32,5x32,5 13"x13" | 169,75

beige

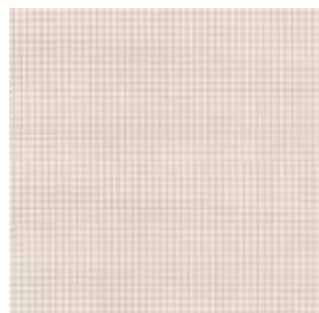

I1W9 | 32,5x32,5 13"x13" | 169,75

tortora

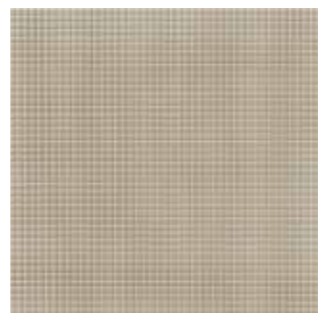

I2W2 | 32,5x32,5 13"x13" | 169,75

## NIDO D'APE / MINI MOSAICO

Per la disponibilità articolo: [www.tuscaniagres.it](http://www.tuscaniagres.it)  
digitando il codice web segnalato a lato dei formati.  
For the item's availability: [www.tuscaniagres.it](http://www.tuscaniagres.it)  
type the web code reported next to the sizes.  
Pour vérifier la disponibilité de l'article: [www.tuscaniagres.it](http://www.tuscaniagres.it)  
en saisissant le code web indiqué à coté des formats.  
Für die Artikelverfügbarkeit: [www.tuscaniagres.it](http://www.tuscaniagres.it)  
web code eingeben, an der Seite von Formaten angeedeutet.

## MINI MOSAICO GRIGIO | 32,5x32,5 cm\_13"x13"



# sezione tecnica



simbologia caratteristiche tecniche symboles technical characteristics symboles des caracteristiques techniques symbole technischen eigenschaften	428
consigli di posa laying recommendations conseils de pose ratschläge für die verlegung	437
consigli per la stuccatura e la pulizia dopo posa recommendations for grouting and cleaning after installation conseils pour le stucage et le nettoyage après la pose ratschläge für die verfugung und erste reinigung nach der verlegung	439

pulizia e manutenzione dei prodotti Tuscania cleaning and care of Tuscania products nettoyage et entretien des articles Tuscania reinigung und pflege der produkte von Tuscania	442
avvertenze warning instructions instructions hinweise	450
coefficiente di attrito (scivolosità) coefficient of friction (slipperiness) coefficient de frottement (antidérapant) rutschfestigkeit	451
listello coprispigolo edge-protection batten baguette d'angle randabdeckleiste	452

certificazioni certifications certifications zertifizierungen	453
legenda legend légend zeichenerklärung	453
condizioni generali di vendita general conditions of sale conditions générales de vente allgemeine verkaufsbedingungen	454
tabella pesi ed imballi sizes weight and packaging mesures poids et emballages tabelle der gewichte und verpackungen	456

# technical section section technique technischen teil

Piastrelle in monocottura atomizzata pasta bianca . Single-fired (atomized white body) tiles ( serie: Manhattan - Nido d'ape - Mini mosaico)  
 Conforme / According To: **ANSI A137.1 (glazed non vitreous wall tiles - P4 Class)**

TUSCANIA CERAMICHE	CARATTERISTICHE TECNICHE TECHNICAL CHARACTERISTICS CARACTERISTIQUES TECHNIQUES TECHNISCHE MERKMALE		NORMA DI RIFERIMENTO REFERENCE STANDARD NORME DE REFERENCE PRÜFMETHODE		VALORE RICHIESTO REQUIRED VALUE VALEUR REQUISE SOLLWERT		VALORE MEDIO TUSCANIA AV. TUSCANIA VALUE VALEUR MOYENNE TUSCANIA MITTLERER TUSCANIA-WERT	
	DIMENSIONI DIMENSIONS DIMENSIONS ABMESSUNGEN		ISO 10545-2		CONFORME COMPLIANT CONFORME KONFORM		CONFORME COMPLIANT CONFORME KONFORM	
	ASSORBIMENTO D'ACQUA WATER ABSORPTION ABSORPTION D'EAU WASSERAUFNAHME		ISO 10545-3		≤ 0,5 %		CONFORME COMPLIANT CONFORME KONFORM	
	RESISTENZA A FLESSIONE MODULUS OF RUPTURE RESISTANCE A LA FLEXION BIEGEFESTIGKEIT		ISO 10545-4		MODULUS OF RUPTURE R ≥ 35 N/MM <sup>2</sup> BREAKING STRENGTH S ≥ 1300 N		CONFORME COMPLIANT CONFORME KONFORM	
	RESISTENZA ALL'ABRASIONE ABRASION RESISTANCE RÉSISTANCE À L'ABRASION ABRIEBBESTÄNDIGKEIT		ISO 10545-7		PEI SOLO PER PIASTRELLE SMALTATE ONLY FOR GLAZED TILES			
	DILATAZIONE TERMICA LINEARE LINEAR THERMAL EXPANSION DILATATION THERMIQUE LINEAIRE LINEARE WÄRMEAUSDEHNUNG		ISO 10545-8		≤ 9x10 <sup>-5</sup> °C <sup>-1</sup>		CONFORME COMPLIANT CONFORME KONFORM	
	RESISTENZA AGLI SBALZI TERMICI THERMAL SHOCK RESISTANCE RESISTANCE AUX ECARTS DE TEMPERATURE ITEMPERATURWECHSELBESTÄNDIGKEIT		ISO 10545-9		RESISTENTE RESISTANT RESISTANT BESTÄNDIG		RESISTENTE RESISTANT RESISTANT BESTÄNDIG	
	RESISTENZA AL GELO FROST RESISTANCE RESISTANCE AU GEL FROSTBESTÄNDIGKEIT		ISO 10545-12		RESISTENTE RESISTANT RESISTANT BESTÄNDIG		RESISTENTE RESISTANT RESISTANT BESTÄNDIG	
	RESISTENZA AGLI ACIDI ED ALLE BASI ACID AND ALKALI RESISTANCE RESISTANCE AUX ACIDES ET AUX BASES SÄURE- UND LAUGENBESTÄNDIGKEIT		ISO 10545-13		CLASS GB MIN.		LOW CONCENTRATION GLA HIGH CONCENTRATION GHA	
	RESISTENZA ALL'ATTACCO CHIMICO CHEMICAL RESISTANCE RESISTANCE À L'ATTAQUE CHEMIQUE CHEMISCHE BESTÄNDIGKEIT		ISO 10545-13		CLASS GB MIN.		GA	
	RESISTENZA ALLE MACCHIE STAIN RESISTANCE RESISTANCE AU TACHES FLECKENBESTÄNDIGKEIT		ISO 10545-14		CLASS 3 MIN.		5	
	COEFFICIENTE DI ATTRITO (SCIVOLOSITÀ) FRICTION COEFFICIENT (SLIPPERINESS) COEFFICIENT DE FRICTION (GLISSEMENT) REIBUNGSKOEFFIZIENT (RUTSCHIGKEIT)		BCR - ITALIA DM DEL 14-06-89 DRY RUBBER 0,62 WET RUBBER 0,51 DRY LEATHER 0,62		ASTM - USA ASTM C1028 DRY NEOLYTHE 0,69 WET NEOLYTHE 0,62		DIN - GERMANIA DIN 51130 R9-R12 ZH 1/571	
THE PRODUCTS HAVING AN ABSORPTION < 0,5% ARE CLASSIFIED ACCORDING TO THE UNI CEN STANDARDS "FULLY VITRIFIED TILES" AND ACCORDING TO THE ASTM STANDARDS "IMPERVIOUS TILES"								

TUSCANIA CERAMICHE	CARATTERISTICHE TECNICHE TECHNICAL CHARACTERISTICS		NORMA DI RIFERIMENTO REFERENCE STANDARD		VALORE RICHIESTO REQUIRED VALUE		VALORE MEDIO TUSCANIA AV. TUSCANIA VALUE	
	ASSORBIMENTO D'ACQUA (E) WATER ABSORPTION (E)		ASTM C373		7% < e ≤ 20%		CONFORME COMPLIANT	
	CARICO DI ROTTURA (S) BREAKING STRENGTH (S)		ASTM C648		≥ 125 LBF		≥ 125 LBF	
	DILATAZIONE TERMICA LINEARE LINEAR THERMAL EXPANSION		ASTM C372		REQUISITO NON PREVISTO NO PROVISION		α ≤ 8 x 10 <sup>-6</sup> °C <sup>-1</sup> α ≤ 4.4 x 10 <sup>-6</sup> °F <sup>-1</sup>	
	RESISTENZA AGLI SBALZI TERMICI THERMAL SHOCK RESISTANCE		ASTM C484		NESSUNA ALTERAZIONE NO ALTERATIONS		RESISTENTE RESISTANT	
	RESISTENZA AL CAVILLO CRAZING RESISTANCE RÉSISTANCE AU TRESSILLAGE HAARISSBESTÄNDIGKEIT		ASTM C424		NESSUNA ALTERAZIONE NO ALTERATIONS		RESISTENTE RESISTANT	
	RESISTENZA ALL'ATTACCO CHIMICO CHEMICAL RESISTANCE		ASTM C650		COME INDICATO DAL PRODUTTORE AS INDICATED BY MANUFACTURER		RESISTENTE (1) RESISTANT	
	RESISTENZA ALLE MACCHIE STAIN RESISTANCE		ASTM C1378		REQUISITO NON PREVISTO NO PROVISION		RESISTENTE RESISTANT	
	CESSIONE DI PIOMBO E CADMIO LEAD AND CADMIUM GIVEN OFF		ASTM C895		REQUISITO NON PREVISTO NO PROVISION		RESISTENTE RESISTANT	
	RESISTENZA AL GELO FROST RESISTANCE		ASTM C1026		REQUISITO NON PREVISTO NO PROVISION		NON RESISTENTE NOT RESISTANT	
	RESISTENZA AL DISTACCO DA MALTA STANDARD BOND STRENGTH		ASTM C482		≥ 50 PSI		CONFORME CONFORMS	
	CARATTERISTICHE DIMENSIONALI DIMENSIONS		PLANARITÀ DEI LATI EDGE WARPAGE	ASTM C485	RETTIFICATO / RECTIFIED - 0.30% / + 0.40% OR MAX - 0.04" / +0.05"	CALIBRATO / CALIBRATED - 0.30% / + 0.40% OR MAX - 0.04" / +0.05"	CONFORME COMPLIANT	
			PLANARITÀ DIAGONALI DIAGONAL WARPAGE	ASTM C485	RETTIFICATO / RECTIFIED - 0.30% / + 0.40% OR MAX - 0.05" / +0.07"	CALIBRATO / CALIBRATED - 0.30% / + 0.40% OR MAX - 0.05" / +0.07"	CONFORME COMPLIANT	
			DIMENSIONI NOMINALI NOMINAL DIMENSIONS	ASTM C499	RETTIFICATO / RECTIFIED ± 2.0% OF NOMINAL DIMENSIONS	CALIBRATO / CALIBRATED ± 2.0% OF NOMINAL DIMENSIONS	± 1.0%	
			INTERVALLO CALIBRO CALIBER RANGE	ASTM C499	RETTIFICATO / RECTIFIED ± 0.25% OR MAX ± 0.03"	CALIBRATO / CALIBRATED ± 0.30% OR MAX ± 0.04"	CONFORME COMPLIANT	
			SPESSORE THICKNESS	ASTM C499	≤ 0.031"	≤ 0.031"	CONFORME COMPLIANT	
			PARALLELISMO DEI LATI WEDGING	ASTM C502	RETTIFICATO / RECTIFIED ± 0.25% OR MAX ± 0.03"	CALIBRATO / CALIBRATED ± 0.40% OR MAX ± 0.05"	CONFORME COMPLIANT	

GL: Monocottura . Single-fired tile

(1) AD ESCLUSIONE DELL'ACIDO FLUORIDRICO E SUOI DERIVATI / EXCLUDING HYDROFLUORIC ACID AND ITS DERIVATIVES



Rivestimenti in bicottura . Double firing wall tiles . Carreaux de mur en biccuisson . Wandfliesen zweimal-brand verfahren: 25x60 - 20x50

UNI EN1441 GRUPPO BIII GL



	CARATTERISTICHE TECNICHE TECHNICAL CHARACTERISTICS CARACTÉRISTIQUES TECHNIQUES TECHNISCHE MERKMALE	NORMA DI RIFERIMENTO REFERENCE STANDARD NORME DE REFERENCE PRÜFMETHODE	VALORE RICHIESTO REQUIRED VALUE VALEUR REQUISE SOLLWERT	VALORE MEDIO TUSCANIA AV. TUSCANIA VALUE VALEUR MOYENNE TUSCANIA MITTLERER TUSCANIA-WERT
	LUNGHEZZA E LARGHEZZA LENGTH AND WIDTH LÄNGE UND BREITE LONGUEUR ET LARGEUR	ISO 10545-2	± 0,50%	CONFORME COMPLIANT CONFORME KONFORM
	RETTILINEITÀ SPIGOLI STRAIGHTNESS OF SIDES KANTENGERADHEIT RECITUDE DES ARÊTES	ISO 10545-2	± 0,3%	CONFORME COMPLIANT CONFORME KONFORM
	ORTOGONALITÀ RECTANGULARITY RECHTWINKLIGKEIT ORTHOGONALITÉ	ISO 10545-2	± 0,5%	CONFORME COMPLIANT CONFORME KONFORM
	PLANARITÀ WARPAGE EBENFLÄCHIGKEIT PLANÉITÉ	ISO 10545-2	CURVATURA DEL CENTRO ± 0,5%/-0,3% CURVATURA DEL LATO ± 0,5%/-0,3% SVERGOLAMENTO ± 0,5%	CONFORME COMPLIANT CONFORME KONFORM
	SPESSORE THICKNESS STÄRKE ÉPAISSEUR	ISO 10545-2	± 10%	CONFORME COMPLIANT CONFORME KONFORM
	ASSORBIMENTO D'ACQUA WATER ABSORPTION ABSORPTION D'EAU WASSERAUFNAHME	ISO 10545-3	> 10%	CONFORME COMPLIANT CONFORME KONFORM
	RESISTENZA A FLESSIONE BREAKING STRENGTH RESISTANCE A LA FLEXION BIEGEFESTIGKEIT	ISO 10545-4	≥ 15 N/mm <sup>2</sup>	CONFORME COMPLIANT CONFORME KONFORM
	FORZA DI ROTTURA BREAKING FORCE IN N CHARGE DE RUPTURE BRUCHLAST IN N	ISO 10545-4	200 N	CONFORME COMPLIANT CONFORME KONFORM
	RESISTENZA AGLI SBALZI TERMICI THERMAL SHOCK RESISTANCE RESISTANCE AUX ECARTS DE TEMPERATURE ITEMPERATURWECHSELBESTÄNDIGKEIT	ISO 10545-9	MPD	CONFORME COMPLIANT CONFORME KONFORM
	RESISTENZA AL CAVILLO CRAZING RESISTANCE RÉSISTANCE AU TRESSILLAGE HAARISSBESTÄNDIGKEIT	ISO 10545-11	RICHIESTA REQUEST	CONFORME COMPLIANT CONFORME KONFORM
	RESISTENZA ALL'ATTACCO CHIMICO CHEMICAL RESISTANCE RESISTANCE À L'ATTAQUE CHEMIQUE CHEMISCHE BESTÄNDIGKEIT	ISO 10545-13	CLASSE GB MIN	CONFORME COMPLIANT CONFORME KONFORM
	RESISTENZA ALLE MACCHIE STAIN RESISTANCE RESISTANCE AU TACHES FLECKENBESTÄNDIGKEIT	ISO 10545-14	CLASS 3 MIN.	CONFORME COMPLIANT CONFORME KONFORM

	<b>MODENA CENTRO PROVE s.r.l.</b> Sede legale e Laboratori: 41123 Modena (Italy) - Via Sallustio, 78 Tel. 059 822417 r.a. - Fax 059380281 - e-mail : <a href="mailto:info@modenacentroprove.it">info@modenacentroprove.it</a> - <a href="http://www.modenacentroprove.com">www.modenacentroprove.com</a> C.C.I.A.A. Modena n. 228587 - Tribunale di Modena n° 2231 - C.F. e P. IVA n. 01592020364
	MECCANICA      ECOLOGIA      CERAMICA      ALIMENTARE

Certificato n°  
50 100 4582

Diploma  
IWR/IT n°  
30438

Socio

Membro

Socio

Unione Industriali  
Modena

Iscritto

Modena, 26/02/17

Spett.le **TUSCANIA S.P.A.**  
VIA GIARDINI SUD 4603  
41028 SERRAMAZZONI MO

MATERIALE e/o CAMPIONE in prova	Denominazione Campione	Riferimento Cliente	del
PIASTRELLE CERAMICHE	20X50	NS RITIRO	20/02/2017

Unitamente alla presente, Vi inviamo i Rapporti di Prova della serie n° **20171179/n**, che riportano i risultati degli esami richiesti.

**MODENA CENTRO PROVE**

*Dr. Sant'Unione Giuseppe*  
Direttore  
Dr. Sant'Unione Giuseppe

	<b>MODENA CENTRO PROVE s.r.l.</b>
	Sede legale e Laboratori: 41123 Modena (Italy) - Via Sallustio, 78 Tel. 059822417 r.a. - Fax 059380281 - e-mail : <a href="mailto:info@modenacentroprove.it">info@modenacentroprove.it</a> - www.modenacentroprove.com C.C.I.A.A. Modena n. 228587 - Tribunale di Modena n° 2231 - C.F. e P. IVA n. 01592020364

	<b>MODENA CENTRO PROVE s.r.l.</b>
	Sede legale e Laboratori: 41123 Modena (Italy) - Via Sallustio, 78 Tel. 059822417 r.a. - Fax 059380281 - e-mail : <a href="mailto:info@modenacentroprove.it">info@modenacentroprove.it</a> - www.modenacentroprove.com C.C.I.A.A. Modena n. 228587 - Tribunale di Modena n° 2231 - C.F. e P. IVA n. 01592020364

**RAPPORTO di PROVA : 20171179/1**

Modena, 26/02/17

**CLIENTE** TUSCANIA S.P.A. - - VIA GIARDINI SUD 4603 - 41028 - SERRAMAZZONI - MO

**MATERIALE e/o CAMPIONE in prova** PIASTRELLE CERAMICHE;

**Denominazione** 20X50;

**Data di ricevimento campione** 20/02/2017;

**Tipo di Prova effettuato** Determinazione dell'Assorbimento d'Acqua

**Norma/Metodo di riferimento** ASTM C373-2016

**Scostamenti dalla Norma/Metodo** Nessuno

**Strumentazione utilizzata** Bilancia Kern cod. MCP C30 ; Stufa Nannetti cod. MCP C43;

**Taratura** C30: LAT 310B/14 del 01/12/2014 - C43: LAT 214-SE-16 del 05/05/2016 -

**Fasi subappaltate** Nessuna

**Campionamento a cura di** Cliente

*I risultati delle prove riportati nel presente Rapporto di Prova si riferiscono unicamente al campione prelevato dal nostro personale e/o conferito dal Committente; questi si impegna a riprodurre integralmente questo documento. E' vietata ogni forma di riproduzione parziale. I tempi di conservazione dei campioni sono indicati sull'offerta o contratto a cui il presente Rapporto di Prova fa riferimento.*

 Operatore p.f. Nasseti Luca	 Responsabile Sezione Ceramica P.I. De Pasquale Roberto	 Direttore Dr. Sant'Unione Giuseppe
---	--	--

**DETERMINAZIONE DELL'ASSORBIMENTO D'ACQUA**

Data di inizio prova : 02/22/2017

Data di fine prova : 02/23/2017

**CAMPIONE** : Piastrelle ceramiche, contrassegnate « 20X50 »



La prova e' stata eseguita col seguente procedimento:

1. Le piastrelle vengono tagliate come previsto dalla norma; devono essere testati almeno 5 campioni
2. I campioni sono essiccati a massa costante
3. La massa di acqua assorbita è determinata mediante il metodo di impregnazione sottovuoto

**RISULTATI**

Campione n°	Assorbimento di acqua (%)
1	19,66%
2	19,30%
3	19,35%
4	19,93%
5	19,37%
<b>Valore medio</b>	<b>19,52%</b>

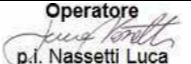
Classificazione ANSI A137.1-2012: P4

 Operatore p.f. Nasseti Luca	 Responsabile Sezione Ceramica P.I. De Pasquale Roberto	 Direttore Dr. Sant'Unione Giuseppe
---	--	--

	<b>MODENA CENTRO PROVE s.r.l.</b> Sede legale e Laboratori: 41123 Modena (Italy) - Via Sallustio, 78 Tel. 059 822417 r.a. - Fax 059380281 - e-mail : <a href="mailto:info@modenacentroprove.it">info@modenacentroprove.it</a> - www.modenacentroprove.com C.C.I.A.A. Modena n. 228587 - Tribunale di Modena n° 2231 - C.F. e P. IVA n. 01592020364
	MECCANICA      ECOLOGIA      CERAMICA      ALIMENTARE

	<b>MODENA CENTRO PROVE s.r.l.</b> Sede legale e Laboratori: 41123 Modena (Italy) - Via Sallustio, 78 Tel. 059822417 r.a. - Fax 059380281 - e-mail : <a href="mailto:info@modenacentroprove.it">info@modenacentroprove.it</a> - www.modenacentroprove.com C.C.I.A.A. Modena n. 228587 - Tribunale di Modena n° 2231 - C.F. e P. IVA n. 01592020364
	MECCANICA      ECOLOGIA      CERAMICA      ALIMENTARE

**TEST REPORT: 20171179/1**

Modena, 26/02/17

<b>CUSTOMER</b>	<b>TUSCANIA S.P.A. - - VIA GIARDINI SUD 4603 - 41028 - SERRAMAZZONI - MO</b>
<b>MATERIAL and/o SAMPLE to be tested</b>	CERAMIC TILES;
<b>Denomination</b>	20X50;
<b>Date of sample reception</b>	20/02/2017;
<b>Kind of test executed</b>	Determination of Water Absorption
<b>Referring standards</b>	ASTM C373-2016
<b>Shifting from standards</b>	No one
<b>Equipment</b>	Scales cod. MCP C30 - Forced ventilation stove cod. C43
<b>Calibration</b>	C30: LAT 310B/14 of 01/12/2014- C43: LAT 214-SE-16 of 05/05/2016
<b>Subcontracted phases</b>	No one
<b>Sampling made by</b>	Customer

*The test results showing in this Report are only referred to the sample taken by our staff or supplied by the Customer. He commits himself to reproduce integrally this document. Partial reproduction is forbidden.  
The times of retain of the samples was indicated in the offer related to the test report.*



Certificato n° 50 100 4582



Diploma IWR/IT n° 30438



Socio



Membro



Socio



Unione Industriali Modena



Iscritto

Modena, 26/02/17



To **TUSCANIA S.P.A.**  
VIA GIARDINI SUD 4603  
41028 SERRAMAZZONI MO

MATERIAL and/or SAMPLE to be tested	Denomination of the Sample	Client Reference – Your delivery	date
CERAMIC TILES	20X50		20/02/2017

Here attached, you will receive the Test Report of Serial No. **20171179/n**, which shows the results of tests required.

**MODENA CENTRO PROVE**

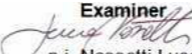
MODENA CENTRO PROVE  
Director  
Sant'Unione dr. Giuseppe

<b>Examiner</b>  p.i. Nassetti Luca	MODENA CENTRO PROVE  Ceramic Dept. Responsible P.I. De Pasquale Roberto	MODENA CENTRO PROVE  Director Sant'Unione dr. Giuseppe
--	---	--

	<b>MODENA CENTRO PROVE s.r.l.</b> Sede legale e Laboratori: 41123 Modena (Italy) - Via Sallustio, 78 Tel. 059822417 r.a. - Fax 059380281 - e-mail : <a href="mailto:info@modenacentroprove.it">info@modenacentroprove.it</a> - www.modenacentroprove.com C.C.I.A.A. Modena n. 228587 - Tribunale di Modena n° 2231 - C.F. e P. IVA n. 01592020364
---	--

**DETERMINATION OF THE INTENSITY OF WATER ABSORPTION**

Beginning date : 02/22/2017

Analysis ending date : 02/23/2017

**SAMPLE** : Ceramic tiles, marked « 20X50 »

The test was performed with the following test procedure:

1. The tiles are cut following the standard rules and at least 5 samples are obtained
2. Samples are dried to a constant mass
3. The saturated mass is determined using water impregnation vacuum method

**RESULTS**

Sample n°	Water Absorption (%)
1	19,66%
2	19,30%
3	19,35%
4	19,93%
5	19,37%
<b>Average value</b>	<b>19,52%</b>

Classification ANSI A137.1-2012: P4

Examiner  p.i. Nassetti Luca	MODENA CENTRO PROVE  Ceramic Dept. Responsible P. De Pasquale Roberto	MODENA CENTRO PROVE  Director Sant'Unione dr. Giuseppe
---	---	--

Di seguito indichiamo alcuni consigli per valorizzare le caratteristiche dei nostri prodotti in fase di posa. In preparazione alla posa, si raccomanda di controllare il tono, il calibro e la scelta. L'utilizzo di materiale diverso da quello ordinato o difettoso significa l'accettazione delle caratteristiche qualitative ed esclude contestazioni. Non saranno accettati reclami su materiale già posato con difetti visibili prima della posa. Il nostro materiale è deliberatamente prodotto e scelto con leggere differenze di tonalità che esaltano gli effetti delle grafiche e dei colori. Un accorgimento basilare per la posa del nostro prodotto è quello di alternare con cura le differenti tonalità prelevando le piastrelle a gruppi di 3 o 4 per volta da almeno cinque scatole diverse, in particolare per l'utilizzo di serie con un grado di stonizzazione e miscelazione cromatica uguale o superiore al valore V2. Raccomandiamo di disporre le venature delle piastrelle in modo da ottenere il migliore effetto estetico e cromatico distribuendo in modo armonioso le diverse nuance di colore che si evidenziano controllando il risultato di tanto in tanto, osservando da opportuna distanza una porzione di lavoro eseguita. Durante le operazioni di posa, soprattutto nella posa a formati misti, adottare una fuga minima di 7 mm. Per la posa di materiali rettificati è comunque sempre indispensabile mantenere una fuga minima di 2/3 mm da una piastrella all'altra usufruendo di stucchi e sigillanti di colore coordinato a quello del materiale. Nella posa di materiali rettificati rettangolari, è importante evitare di far collimare i vertici di una piastrella con la metà delle altre, al fine di sopperire alle eventuali imperfezioni di planarità presenti comunque in tutti i grandi formati. Trattandosi di materiale tagliato e rettificato, per evitare questo problema, è consigliabile posare il materiale a correre, con intervallo da 6 a 15 cm tra ogni piastrella come da schema sotto riportato (v. disegno). È fortemente auspicabile affidare la posa a personale esperto che, dopo aver verificato la corretta planarità della caldana e la qualità del materiale, contribuirà alla impeccabile esecuzione dell'incarico.

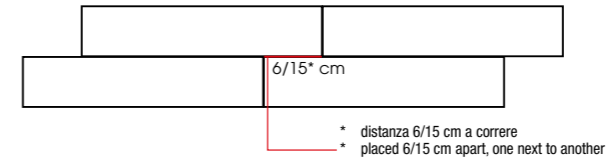

Per quanto riguarda la posa all'esterno è opportuno seguire accuratamente alcuni accorgimenti:

- 1) Suddivisione della pavimentazione in "maglie" di superficie ridotta, mediante giunti di dilatazione; si consiglia, ogni 5/10 mq, di posizionare il giunto seguendo le più probabili linee di scarico delle tensioni da dilatazione termiche.
  - 2) Creare opportuni drenaggi nel sottofondo nonché pendenza (almeno 1%) e planarità della superficie onde evitare il ristagno dell'acqua sia nel sottofondo che in superficie.
  - 3) Il massetto deve essere gettato su uno strato impermeabilizzante, di uno spessore di almeno 5 cm.
  - 4) Prima della posa assicurarsi che non permangano zone a grossa infiltrazione di umidità, tubazioni e canalizzazioni siano ben protette e issate e siano terminati i lavori edili più grossi.
  - 5) Si devono utilizzare sia collanti che materiali per le fughe idonei alla posa all'esterno quindi idrorepellenti. La fuga non deve essere inferiore ai 7 mm.
  - 6) Per evitare infiltrazioni di acqua in corrispondenza delle stuccature sarebbe opportuno impregnare le stesse con liquido impermeabilizzante.
- Consigliamo molta attenzione nell'uso di materiali fugganti in quanto i coloranti in essi contenuti possono macchiare le superfici smaltate. Durante la posa è necessario non segnare il materiale sulla superficie di utilizzo con matite (grafite) o pennarelli indelebili, in particolar modo per prodotti lappati. Sugeriamo infine di adattarsi al sistema di posa R.L.S. (Raimondi Levelling System) per il quale vi forniamo le seguenti indicazioni.

**Il sistema R.L.S.**

Il sistema R.L.S. rivoluziona il mondo della posa garantendo di ottenere con semplicità e rapidità pavimenti perfettamente livellati eliminando i dislivelli tra le piastrelle. R.L.S. è perfetto per grandi formati e piastrelle "ultrasottili" (3/5 mm). R.L.S. è composto di 3 elementi: base, cuneo, pinza. Le basi sono disponibili in due diverse versioni: per piastrelle di spessore compreso tra i 3 e i 12 mm; le piastrelle di spessore compreso tra 12 e 20 mm. Il cuneo è unico per entrambi le basi ed è riutilizzabile infinite volte. La pinza regolabile è disponibile in versione per posa a pavimento e in versione per posa a rivestimento ed è consigliata per inserire con facilità i cunei nelle basi; ottimizzando al contempo la pressione esercitata sulla piastrella. La pinza è unica indipendentemente dallo spessore della piastrella.

**COME SI USA**

- Posizionamento del supporto:
- 1) Dopo aver steso l'adesivo inserire il supporto al di sotto delle piastrelle in corrispondenza dei 4 lati.
  - 2) In funzione del formato della piastrella posizionare uno o più supporti per ogni lato della piastrella.
- Inserimento del cuneo:
- 1) Inserire il cuneo nella feritoia del supporto facendo attenzione a non superare il punto di rottura.
  - 2) Per agevolare l'inserimento del cuneo si consiglia l'uso della pinza a trazione regolabile.
- Eliminazione del supporto:
- A maturazione avvenuta, la parte sporgente del supporto si separa dalla base battendo, nella direzione della linea di fuga, con un martello in gomma o col piede.
- Per maggiori informazioni è disponibile un esauritivo video sul sistema R.L.S. nella sezione Video del sito: [www.raimondiutensili.it](http://www.raimondiutensili.it)

Raimondi . Via dei Tipografi, 11 - 41122 Modena (Italy) - Tel. +39 059 280 888 / Fax +39 059 282 808 [www.raimondiutensili.it](http://www.raimondiutensili.it) - [raimens@raimondiutensili.it](mailto:raimens@raimondiutensili.it)



**Avvertenze**

Lavaggio e pulizia dopo posa  
 Il lavaggio dopo posa è una fase di fondamentale importanza per tutti gli interventi successivi e per la manutenzione. La rimozione inadeguata o tardiva dei residui della stuccatura utilizzata per le fughe, può lasciare alonature difficili da rimuovere e creare sulla pavimentazione un film cementizio capace di assorbire ogni forma di sporco, dando così l'impressione che sia il materiale a sporcarsi.  
 Con il lavaggio dopo posa:  
 1) Si eliminano i residui di posa (malta, colla, vernice, sporco da cantiere di varia natura).  
 2) Si rimuovono eventuali residui superficiali del materiale.  
 È bene sapere che oltre il 90% delle contestazioni in cantiere è dovuta ad un cattivo, o addirittura inesistente, lavaggio dopo posa.

- 1) NON SI ACCETTANO CONTESTAZIONI PER MATERIALE POSATO
  - 2) CONTROLLARE TONO, CALIBRO, SCELTA E PLANARITA' PRIMA DELLA POSA DEL MATERIALE
  - 3) LE MACCHINE ELETTRONICHE CHE STABILISCONO IL CALIBRO SONO TARATE CON UNA TOLLERANZA DI 1,2 MM
  - 4) IL MATERIALE DEVE ESSERE POSATO CON UN MINIMO DI FUGA DI 3 MM. IL MATERIALE RETTIFICATO DEVE ESSERE POSATO CON UNA FUGA MINIMA DI 2 MM.
- Le serie Terre Toscane e Camelot devono essere posate con una fuga di 5 mm.

Below, we provide some recommendations for enhancing the features of our products during laying. Before laying, we recommend that you check the colour, size and quality. The use of materials that are different than you ordered, or defective, indicates acceptance of the quality of the materials and rules out claims. We will not accept claims regarding installed materials with defects that were visible before laying. Our materials are deliberately produced and selected with slight tonal variations that enhance the effects of the graphics and colours. On basic technique for installing our products is to carefully alternate different tones by picking tiles in groups of 3 or 4 from at least five different boxes and, especially, the use of series with a degree of tonal variation and chromatic mixing equal to, or greater than, a value of V2. We recommend that you orient the grain of the tiles to obtain the best aesthetic and chromatic effect by harmoniously distributing the different colour nuances that can be seen by checking the results from time to time, looking at a portion of the floor from a suitable distance. During laying and especially when laying mixed sizes, use minimum joint spacing of 7 mm. When installing rectified materials it is indispensable, in any case, to maintain a minimum joint space of 2-3 mm between tiles, using stuccos and sealants whose colour is coordinated with that of the material. When installing rectangular rectified materials, it is important to avoid placing the vertex of one tile near the middle of the others in order to compensate for any imperfections of planarity that are, in any case, present in all the large sizes. Since this is cut and rectified material, to avoid this problem, we recommend that you lay the material longitudinally, with a space of 6 to 15 cm between each tile, as shown below (see drawing). We strongly recommend that laying be performed by expert personnel who, after checking the correct planarity of the concrete slab and the quality of the material, will be able to install it in the best way possible.

As for an outside laying, we recommend that you carefully use several techniques:

- 1) Divide the floor into "grids" of smaller surface areas using dilation joints; we recommend placing a joint every 5-10 m<sup>2</sup> following the most probable lines for discharging the tensions of thermal dilations.
  - 2) Create suitable drainages in the foundation as well as a slope (of at least 1%) and a flat surface in order to avoid pools of water on both the foundation and the surface.
  - 3) The concrete slab must be cast on a waterproofing layer at least 5 cm thick.
  - 4) Before laying, make sure there are no areas with large infiltrations of humidity, that pipes and channels and well-protected and that the larger construction works have been completed.
  - 5) You must use mastics and grouts that are suitable for external use and, thus, waterproof. The joint space between tiles must not be less than 7 mm.
  - 6) To avoid water infiltrating the grout, it is a good idea to impregnate it with waterproofing liquid.
- We recommend care in the use of grouts because their colourings can stain glazed surfaces. During laying, the surface of the material must not be marked with pencil (graphite) or indelible marker, especially honed products. Our recommendation is to follow the laying pattern R.L.S. (Raimondi Levelling System) for which we provide the following information.

**R.L.S. System**

Raimondi Levelling System (R.L.S.) is a revolution in the tile setting. In addition to ensuring the proper leveling of tiles, this system helps to speed up the tile setting process. R.L.S. is strongly recommended when installing flexible, large format, heavy or low-thickness tiles (3/5 mm; 1/8" - 3/16"). R.L.S. is made up of three elements: clips (spacers), wedges and pliers. Clips are available in two different versions: for tiles from 3 up to 12 mm thickness (1/8" - 1/2"); for tiles from 12 up to 20 mm thickness (1/2" - 3/4"). The wedge works for both clip sizes and it is re-usable virtually forever. Special traction-adjustable pliers are available in two different versions: for floor or for wall coverings. The use of the pliers is suggested for facilitating and speeding up the insertion of the wedge in the clips. It also optimizes the pressure on the tile. R.L.S. is the easiest and quickest to remove leveling system: it is enough to kick the spacers to remove the unnecessary part from the installed floor. No tool required.

**HOW TO USE**

- How to set the support:
- 1) After having spread the adhesive, insert the clip (base/support) underneath the tiles and along the 4 sides.
  - 2) According with tiles size, set one or more clips on every side of the tile.
  - 3) Set the tile and beat it with a rubber mallet.
- How to insert the wedge:
- 1) Insert the wedge in the clip (base) slot paying attention not to pass the breakpoint.
  - 2) To facilitate this operation, the use of the special traction-adjustable-pliers is recommended.
- How to remove the support:
- Once the adhesive is set, the protruding part of the support, has to be removed by separating it from the clip/base. This can be done with a rubber mallet or even with feet. Beat parallel to the joint.
- For further info please watch the exhaustive video of the R.L.S. on web site: [www.raimondiutensili.it](http://www.raimondiutensili.it)

**Warnings**

Washing and cleaning after laying  
 Washing after laying is of fundamental importance for all subsequent steps and maintenance. The inadequate or late removal of the grout used for joints can leave difficult to remove halos and create a cement film on the floor that can absorb all types of dirt, leaving the impression that the material is dirty.  
 Washing after laying:  
 1) Eliminates laying residues (grout, glue, varnish and various kinds of job site dirt).  
 2) Removes any surface residues of the material.  
 You should know that over 90% of job site complaints are due to poor, or actually non-existent, washing after laying.

- 1) NO CLAIMS WILL BE ACCEPTED FOR LAID MATERIALS
  - 2) CHECK THE SHADE, WORKSIZE, SELECTION AND THE WARPAGE BEFORE LAYING THE MATERIAL
  - 3) ELECTRONIC MACHINES THAT SET THE WORKSIZE ARE CALIBRATED WITH A TOLERANCE OF 1.2 MM
  - 4) THE MATERIAL MUST BE LAID WITH A MINIMUM JOINT OF 3 MM. THE RECTIFIED MATERIAL MUST BE LAID WITH A MINIMUM JOINT OF 2 MM.
- The Terre Toscane e Camelot series (thin paving bricks) must be laid with a joint of 5 mm.

## Conseils de pose . grès cérame - Ratschläge für die Verlegung . feinsteinzeug

Ci-après, vous trouverez certains conseils permettant de mettre en valeur les qualités de nos produits durant la phase de pose. Avant la pose, il est conseillé de vérifier le ton, la taille et le choix du produit. L'utilisation d'un matériau différent de celui commandé ou défectueux, signifie que vous acceptez la qualité du produit en votre possession et exclut toutes réclamations. Nous n'acceptons pas les réclamations sur les matériaux déjà posés présentant des défauts visibles avant la pose.

Nos matériaux comportent délibérément de légères différences de tons qui mettent en relief les effets du graphisme et des couleurs. Un moyen simple d'effectuer la pose de notre produit est d'alterner avec soin les différents tons en prélevant les carreaux par groupe de 3 ou 4 dans au moins cinq boîtes différentes, en particulier pour les séries avec un degré de dénuancement et de mélange chromatique égal ou supérieur à la valeur V2. Nous vous conseillons de disposer les veines des carreaux de manière à obtenir le meilleur effet esthétique et chromatique, de répartir harmonieusement les différentes nuances de couleur qui apparaissent et de contrôler le résultat de temps en temps en observant à bonne distance le groupe de carreaux à peine posés. Durant les opérations de pose, en particulier pour la pose de carreaux de tailles différentes, veuillez adopter un joint minimal de 7 mm.

Pour la pose de matériaux rectifiés et dans tous les cas, veuillez appliquer un joint de 2/3 mm d'un carreau à l'autre en utilisant des stucs et des mastics de couleurs coordonnées à celles des matériaux. Durant la pose de matériaux rectifiés rectangulaires, il est important d'éviter de faire coïncider les sommets d'un carreau avec le milieu des autres afin de pouvoir aux éventuelles imperfections de planéité toujours présentes dans les carreaux de grandes tailles. S'il s'agit de matériaux coupés et rectifiés, pour éviter cette difficulté, il est conseillé de poser les carreaux en coupe perdue et de laisser un intervalle de 6 à 15 cm entre chaque carreau comme indiqué sur le dessin ci-dessous (observer le dessin). Il est fortement recommandé de confier la pose à un personnel expert qui après avoir vérifié que la planéité de la chape est correcte et la qualité du matériau, exécutera la pose impeccablement.

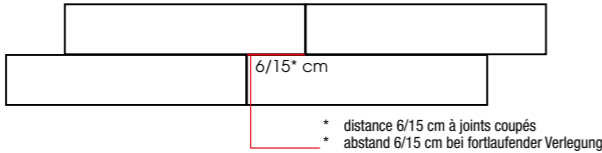

- \* distance 6/15 cm à joints coupés
- \* abstand 6/15 cm bei fortlaufender Verlegung

Concernant la pose en extérieur il est recommandé de suivre scrupuleusement certaines indications:

- Subdivision du revêtement de sol en "maillles" de surfaces réduites au moyen de joints de dilatation; il est recommandé de positionner un joint tous les 5/10 m² en suivant les lignes les plus probables de la perte de charge de tension par dilatation thermique.
- Créer les drainages nécessaires dans l'hourdis, ainsi qu'une pente (à 1% au moins) et la planéité des surfaces là où il est nécessaire d'éviter que l'eau stagne que ce soit dans l'hourdis comme en surface.
- La dalle doit être coulée sur une couche d'imperméabilisant d'une épaisseur minimale de 5 cm.
- Avant la pose, veuillez vous assurer qu'il ne reste pas de zones de grosses infiltrations d'humidité, que les tuyaux et canalisations sont bien protégés et surélevés et que les plus gros travaux de construction sont terminés.
- Il est nécessaire d'utiliser aussi bien des colles que des matériaux réservés à la pose des joints en extérieur, c'est-à-dire des matériaux hydrofuges. Le joint ne doit pas être inférieur à 7 mm.
- Pour éviter les infiltrations d'eau au niveau des jointements il est recommandé d'imbibes les joints d'un liquide imperméabilisant.

Nous vous conseillons d'appliquer les joints avec beaucoup de précautions dans la mesure où les colorants qu'ils contiennent peuvent tâcher les surfaces vernies. Durant la pose, il ne faut pas marquer le matériau sur la surface d'utilisation au crayon à papier ou au stylo indélébile, en particulier les produits polis.

Notre conseil est celui de suivre le modèles de pose R.L.S. (Raimondi Levelling System) pour lequel on vous fournit les informations suivantes.

#### R.L.S System

Le Raimondi Levelling System (R.L.S.) est une révolution dans la pose des carreaux. En plus d'assurer la mise à niveau correcte des carreaux, ce système permet d'accélérer le processus de pose. Ces croisillons nivelant sont fortement recommandés lors de l'installation de carreaux de grand format, lourds ou de faible épaisseur (3 / 5 mm). Le système R.L.S. est constitué de trois éléments : des bases, des coins et des pinces. Les bases sont disponibles dans deux versions différentes : une pour les carreaux à partir de 3 jusqu'à 12 mm d'épaisseur et l'autre pour les carreaux à partir de 12 jusqu'à 20 mm d'épaisseur. Le coin est utilisable avec les deux types de bases et est réutilisable. Une pince ergonomique de précision est proposé en 2 modèles: pour la pose au sol ou en pose murale. L'utilisation de la pince est conseillée pour faciliter et accélérer l'insertion des coins dans les bases. Il optimise également la pression sur le carreau. Le R.L.S. est le système de nivellement le plus facile et rapide à enlever: il suffit de frapper la base pour enlever la partie inutile ainsi que le coin. Aucun outil n'est nécessaire.

#### UTILISATION

Comment préparer support:

- Après avoir étalé la colle, insérer la base sous les carreaux et le long des 4 côtés.
- Selon la taille de carreaux, fixer une ou plusieurs bases de chaque côté du carreau.
- Régler le carreau et le battre avec un maillet en caoutchouc.

Comment insérer le coin:

- Insérer le coin dans la base, attention de ne pas passer le point d'arrêt (cela casserait la base).
- Pour faciliter cette opération, l'utilisation de la pince est recommandée.

Comment retirer le support:

Une fois que la colle est sèche, la partie saillante de la base doit être enlevé. Cela peut être fait avec un maillet en caoutchouc ou même avec le pied. Taper parallèlement au joint. Pour plus d'info, merci de regarder la vidéo complète des R.L.S. sur site web www.raimondiutensili.it



#### Avvertissements

Lavage et Nettoyage après la pose

Le lavage après la pose est une phase fondamentalement importante pour toutes les interventions qui vont suivre et pour l'entretien.

La suppression inadéquate ou tardive des résidus de stucs utilisés pour les joints peut laisser des auréoles difficiles à retirer et créer un film de ciment sur les sols en mesure d'absorber toute forme de saleté, ce qui donne l'impression que c'est le matériau qui est sale.

Avec le lavage après la pose:

- On élimine les résidus dus à la pose (mortier, colle, vernis, salissures de chantier de différentes sortes).
- On retire les éventuels résidus superficiels du matériau.

Il faut savoir que plus de 90% des réclamations concernant les chantiers sont dues à un mauvais lavage ou même à un lavage inexistant après la pose.

- AUCUNE RÉCLAMATION NE SERA PRISE EN COMPTE EN CAS DE MATERIELLE POSÉ;
- CONTRÔLER LA NUANCE, LE CALIBRE, LE CHOIX ET LA PLANÉITÉ AVANT DE POSER LE MATERIELLE;
- LES MACHINES ÉLECTRONIQUES UTILISÉES POUR DÉTERMINER LE CALIBRE PRÉSENTENT UNE TOLÉRANCE DE CALIBRAGE DE 1,2 MM;
- LE MATERIELLE DOIT ÊTRE POSÉ AVEC UN JOINT DE 3 MM MINIMUM. LE MATERIELLE RECTIFIÉ DOIT ÊTRE POSÉ AVEC UN JOINT DE 2 MM MINIMUM.

Les séries Terre Toscane e Camelot doivent être posées avec un joint de 5 mm.

Folgend sind einige Ratschläge für die Aufwertung der Eigenschaften unserer Produkte während der Verlegung aufgeführt. Vor der Verlegung sollte der Farbton, das Maß und die Wahl kontrolliert werden. Die Verwendung von Material, das nicht dem bestellten entspricht oder Mängel aufweist, setzt die Akzeptierung der qualitativen Eigenschaften voraus und schließt eventuelle Beanstandungen aus. Es werden keine Beanstandungen für schon verlegte Material, die vor der Verlegung sichtbare Mängel aufweisen, akzeptiert.

Unser Material wird absichtlich mit leichten Farbunterschieden hergestellt und ausgewählt, die die Wirkung der Graphiken und Farben hervorheben. Bei der Verlegung unseres Produktes sollten die unterschiedlichen Farbtöne abwechselnd verwendet werden, d.h. die Fliesen sollten jeweils in Dreier- oder Vierergruppen aus mindestens fünf verschiedenen Kartons herausgenommen werden, insbesondere bei der Verwendung von Serien, die einen hohen Abweichungsgrad und eine dem V2 Wert entsprechende oder über ihm liegende Farbmischung aufweisen. Wir empfehlen die Maserung der Fliesen auf ästhetisch und farblich effektvolle Weise anzuordnen und dabei die verschiedenen Nuancen aufeinander abzustimmen. Aus einer gewissen Entfernung sollte das Ergebnis eines fertigen Arbeitsbereiches ab und zu kontrolliert werden. Während der Verlegung und insbesondere bei der Verwendung von gemischten Formaten, sollte eine Fuge von 7 mm vorgesehen werden. Bei der Verlegung von rektifizierten Materialien muss immer eine Mindestfuge von 2-3 mm zwischen den einzelnen Fliesen eingehalten werden, wobei Spachtelmassen und Farbesterger verwendet werden müssen, die auf die des benutzten Materials abgestimmt werden. Bei der Verlegung von rechteckigen rektifizierten Materialien ist es wichtig zu vermeiden, dass die Scheitelpunkte einer Fliese an der Mitte einer anderen Fliese liegen, um eventuelle Defekte in der Planheit der Oberflächen, die bei allen großen Formaten auftreten, zu umgehen. Da es sich hierbei um ein geschmittenes und rektifiziertes Material handelt, ist es empfehlenswert, eine fortlaufende Verlegung, wie in dem folgenden Schema dargestellt (siehe Zeichnung) mit einem Abstand von 6 bis 15 cm zwischen den einzelnen Fliesen anzuwenden, um diesem Problem aus dem Weg zu gehen. Mit der Verlegung sollte unbedingt Fachpersonal beauftragt werden, das nach der Überprüfung der korrekten Ebenmäßigkeit der Wallung und Qualität des Materials eine tadellose Ausführung des Auftrags garantiert.

In Bezug auf die Verlegung in Außenbereichen müssen folgende Maßnahmen ergriffen werden:

- Aufteilung des Fußbodenbelags, mittels Dehnungsfugen, in kleine "gitterförmige" Flächen; Es wird empfohlen, die Fuge alle 5-10 m² gemäß der möglichen, durch die thermische Dehnung verursachten Spannungslinien zu positionieren.
- Realisierung von angemessenen Drainagen im Unterboden sowie einer Neigung (mindestens 1%) und Ebenmäßigkeit der Oberfläche, um eine Wasseransammlung sowohl im Unterboden als auch auf der Oberfläche zu vermeiden.
- Der Estrich muss auf einem wasserundurchlässigen Untergrund von mindestens 5 cm verlegt werden.
- Vor der Verlegung muss sichergestellt werden, dass keine Bereiche frei bleiben, die Feuchtigkeitinfiltrationen ausgesetzt sind, die Leitungen und Kanäle geschützt und die größten Bauarbeiten fertig gestellt sind.
- Es müssen sowohl Klebstoffe als auch Materiale verwendet werden, die für die Verlegung in Außenbereichen geeignet und demnach wasserabweisend sind. Die Fugen müssen eine Breite von mindestens 7 mm aufweisen.
- Um Wasserinfiltrationen entlang der Fugen zu vermeiden, sollten dieselben mit einer wasserundurchlässigen Flüssigkeit bearbeitet werden.

Bei der Verwendung von Fugenmasse sollte große Vorsicht geboten sein, da die in ihr enthaltenen Farbstoffe Flecken auf den glasierten Oberflächen bilden können. Während der Verlegung dürfen keine Zeichen mit Bleistift (Graphit) oder unauslöschbaren Stiften auf den Nutzflächen des Materials gemacht werden, dies gilt insbesondere bei Fliesen in Lappato-Ausführung. Für die Verlegung unsere Produkten, ins besonderes für große Formaten und rechteckige Formaten, wird das Verlegung-System R.L.S. Raimondi Levelling System empfohlen.

#### Was ist der System R.L.S.

Exakte Flächen können nur erreicht werden, wenn die Fliesen perfekt im Niveau verlegt werden. Sehr oft ist es schwierig, grosse Fliesen als auch Fliesen mit geringer Dicke vernünftig zu verlegen, da der Untergrund uneben ist. Das Ergebnis sind Platten, die während der Verlegung perfekt ausgeric htet schienen, weisen nach dem Abbinden des Klebers Differenzen in der Höhe auf. Das Endresultat der Arbeit wird dadurch beeinträchtigt. Dieses Problem kann vermieden werden, wenn Sie die Raimondi Levelling System verwenden. Durch diese wird ein perfektes Niveau erreicht. Der Arbeitsablauf kann ebenso beschleunigt werd en. Die Niveau-Halter machen die Verlegung einfach er, schneller und die Fliesen können eben verlegt werden. Die Fugen müssen mindestens 1,5 mm dick sein Die Plattenstärke muss zwischen 3 und 20 mm liegen.

#### ANWENDUNG

So funktioniert s:

- Nachdem Sie den Kleber aufgetragen haben, legen Sie die Clips unter alle 4 Seiten der Fliesen.
- Verwenden sie je nach Plattenformat einen oder mehrere Clips pro Seite.
- Verlegen Sie die Fliese.

So setzen Sie den Keil ein:

- Setzen Sie den Keil in den Clip. Beachten Sie, dass der Bruchpunkt nicht überschritten wird.
- Um diesen Vorgang zu erleichtern empfehlen wir die Verwendung der verstell baren Zange.

So entfernen Sie die Verlegehilfe:

Sobald der Klebstoff abgebunden hat, können Sie den Vorstehenden Teil des Clips mit einem Schlag mit dem Schuh oder dem Gummihammer entfernen. Zu beachten ist, dass Sie parallel zur Fuge schlagen. Für weitere informationen und 'a Video auf site System R.L.S.: www.raimondiutensili.it

#### Warnings

Waschen und Reinigung nach der Verlegung

Die Reinigung nach der Verlegung ist für alle darauf folgenden Eingriffe und die Wartung von besonderer Wichtigkeit. Eine unsachgemäße oder verspätete Entfernung der Reste des für die Fugen verwendeten Materials kann schwer zu beseitigende Ränder bilden und einen Zementfilm auf dem Bodenbelag zurücklassen, der jede Art von Schmutz aufsaugt und somit den Eindruck verleiht, dass das Material leicht verschmutzt. Mit der Reinigung nach der Verlegung:

- Werden die Reste der Verlegung entfernt (Mörtel, Klebstoff, Farbe, Bauschmutz jeder Art).
- Werden eventuelle oberflächliche Materialreste entfernt.

Es ist wichtig zu wissen, dass 90% der Baustellenbeanstandungen auf eine unsachgemäße oder nicht durchgeführte

Reinigung nach der Verlegung zurückzuführen ist.

- ES WERDEN KEINE BEANSTANDUNGEN AKZEPTIERT, NACHDEM DAS MATERIAL BEREITS VERLEGT WURDE.
- ÜBERPRÜFEN SIE DEN FARBTON, DAS WERKMASS, DIE SORTIERUNG UND DIE EBENFLÄCHIGKEIT, BEVOR SIE DIE FLIESEN VERLEGEN.
- DIE ELEKTRONISCHEN MASCHINEN, DIE DAS WERKMASS BESTIMMEN, SIND AUF EINE TOLERANZ VON 1,2 MM EINGESTELLT.
- DIE FLIESEN MÜSSEN MIT EINER FUGENBREITE VON MINDESTENS 3 MM VERLEGT WERDEN. GESCHLIFFENE FLIESEN MÜSSEN MIT EINER FUGENBREITE VON MINDESTENS 2 MM VERLEGT WERDEN.

Die serien Terre Toscane e Camelot müssen mit einer fugenbreite von 5 mm verlegt werden

## Consigli per la stuccatura e la pulizia dopo posa

La pulizia finale dell'eventuale velo polveroso di stucco dalla superficie si esegue a completa stagionatura dello stucco cementizio (almeno 36-48 ore), eseguendo una pulizia con detergente acido applicabile a mano (spugna o stracci) oppure a macchina (monospazzola) attenendosi scrupolosamente ai consigli di seguito riportati.

#### 1. Prodotti consigliati.

Si consiglia di utilizzare una soluzione acida ad azione tamponata, diluita 1:5 (1 litro in 5 di acqua calda) in acqua possibilmente calda
Quantità d'uso: 6 litri soluzione acida per 100m2.
Evitare assolutamente l'utilizzo di acidi da ferramenta diluiti (per il loro rilascio di fumi nocivi e per la loro azione "bruciante" nei confronti dei giunti).

#### 2. Modalità di esecuzione.

a - Bagnare con acqua solamente lo stucco cementizio in modo da proteggerlo da una eventuale azione corrosiva della soluzione acida diluita;
b - Distribuire uniformemente la soluzione acida diluita utilizzando un normale mop-lavapavimenti (mocio) o uno straccio ruvido per ambienti residenziali oppure frizionando con monospazzola rotante per grandi superfici;
c - Lasciare agire per qualche minuto, in funzione dell'intensità dello sporco;
d - Intervenire energicamente con spugna commerciale scotch-brite o con lo spazzolone;
e - Raccogliere il residuo con stracci oppure con aspiraliquidi.
f - Risciacquare abbondantemente con acqua calda pulita, ripetendo l'operazione anche più volte sino alla eliminazione di qualsiasi alonatura o residuo negli interstizi.

Eseguire una precisa e corretta pulizia del prodotto ceramico è di fondamentale importanza per mantenerne nel tempo l'originaria lucentezza e bellezza. Si raccomanda pertanto di seguire con attenzione le indicazioni seguenti.

#### A) PULIZIA “DOPO-POSA” IN CANTIERE

**Il lavaggio iniziale delle piastrelle nel “dopo-posa” in cantiere è una fase di fondamentale importanza.**

È infatti in questo momento che è possibile rimuovere agevolmente dalle piastrelle tutti i residui dei materiali usati per la posa e/o della stuccatura delle fughe della piastrella stessa.

Si tratta di residui di varia natura che, se lasciati “asciugare e/o seccare” sulle piastrelle, soprattutto in quelle caratterizzate da una superficie strutturata più o meno accentuata potrebbero diventare difficili da rimuovere successivamente. Si raccomanda sempre la massima attenzione alla scelta dell'agente pulente per non alterare irrimediabilmente il grado di lucentezza e brillantezza della piastrella posata.

#### Pulizia del pavimento stuccato con “Stucchi cementizi a base d'acqua”

Come già accennato, con il lavaggio “dopo-posa” si rimuovono i residui di cemento, stucchi cementizi, salnitri, colle ed eventuali residui superficiali del materiale di varia natura. In questa fase il pavimento deve essere lavato con detergenti a base di acidi tamponati entro almeno 3-4 giorni dopo la posa e mai oltre i 10 giorni.

NB: Per i prodotti caratterizzati da superfici strutturate e/o anticivello si raccomanda, viste le asperità della struttura, di sporcare il meno possibile la superficie della piastrella durante le fasi della posa e di pulire bene subito dopo la stuccatura gli eccessi di materiali utilizzati con una spugna bagnata in acqua pulita. Si raccomanda altresì di eseguire la procedura sotto-descritta il prima possibile e comunque prima dei su citati 3-4 giorni massimi dal “dopo-posa”.

**Procedere come segue:**

- Preparare il detergente come indicato in etichetta (si consiglia di effettuare prove preliminari su piastrelle non posate per verificare l'inalterabilità della superficie della piastrella)
- Bagnare preventivamente il pavimento con acqua pulita
- Stendere la soluzione sulle piastrelle lasciando che agisca per qualche minuto
- Passare la monospazzola utilizzando dischi appropriati (verdi per le superfici strutturate e rosso per le non strutturate) o una paglietta (verde per le superfici strutturate e rossa/marrone per le non strutturate) strofinando energicamente la superficie delle piastrelle.
- Risciacquare abbondantemente con acqua pulita aspirando il liquido

PULIZIA FINE CANTIERE STUCCO CEMENTIZIO	TIPO DI DETERGENTE	PRODOTTO	PRODUTTORE
Detergente acido		CEMENT REMOVER	FABER CHIMICA
		KERANET	MAPEI
		DETERDEK	FILA

#### Pulizia del pavimento stuccato con “Stucchi epossidici”

Nel caso di utilizzo di stucchi epossidici, considerato che essi induriscono rapidamente in pochi minuti, il lavaggio “dopo-posa” deve essere eseguito con detergenti alcalini il più rapidamente possibile attenendosi scrupolosamente alle indicazioni e procedure d'utilizzo indicati in etichetta.

Procedere come segue:

- Preparare il detergente come indicato in etichetta (si consiglia di effettuare prove preliminari su piastrelle non posate per verificare l'inalterabilità della superficie della piastrella)
- Bagnare preventivamente il pavimento con acqua pulita
- Stendere la soluzione sulle piastrelle lasciando che agisca per qualche minuto

- Passare la monospazzola utilizzando dischi appropriati (verdi per le superfici strutturate e rosso per le non strutturate) o una paglietta (verde per le superfici strutturate e rossa/marrone per le non strutturate) strofinando energicamente la superficie delle piastrelle.
- Risciacquare abbondantemente con acqua pulita aspirando il liquido

PULIZIA FINE CANTIERE STUCCO EPOSSIDICO	TIPO DI DETERGENTE	PRODOTTO	PRODUTTORE
Detergente alcalino		EPOXY REMOVER	FABER CHIMICA
		FILA CR	10 FILA

#### B) PULIZIA QUOTIDIANA

La pulizia ordinaria può essere fatta con l'ausilio di normali detergenti neutri adatti alla pulizia delle superfici ceramiche, eventualmente diluendoli in acqua calda per aumentarne l'efficacia, attenendosi alle istruzioni in etichetta del produttore

## Recommendations for grouting and cleaning after installation

The final cleaning of any powdery layer of grout from the surface should be carried out when the grout is completely dry (at least 36-48 hours) by cleaning with acid-based detergents by hand (sponge or cloth) or by machine (single brush floor cleaning machine) paying close attention to the recommendations below.

#### 1. Recommended products.

A buffered acid cleaner, diluted in a 1:5 ratio (1 liter in 5 liters of hot water) in hot water if possible is recommended.

Quantity: 6 liters of acid cleaner per 100m2.

Avoid using diluted muriatic acid (due to the release of harmful fumes and the way it “burns” the joints).

#### 2. Procedure

a - Wet the grout with water only in order to protect it from any corrosion from the diluted acid solution;
b - Distribute the diluted acid solution using a normal mop/floor-washer or a coarse rag for residential spaces, or with a single-brush floor washing machine for large surfaces;
c - Allow to act for several minutes depending on how dirty the surface is;
d - Clean vigorously with a commercial scotch-brite sponge or with a scrubber;
e - Wipe up any residue using cloths or with a wet/dry vacuum;
f - Rinse abundantly with clean warm water, repeating the operation several times until any marks or residue in the cracks is eliminated.

To maintain the original shine and beauty of your tiles after fixing, the correct cleaning procedures must be followed.

#### A) IMMEDIATE ACTION AFTER LAYING AND GROUTING:

**Cleaning the tiles immediately after the initial fixing and, again after the grouting, is very important.**

At this point thoroughly wash the surface and joints of the tile with clean water several times. This will ensure any residual adhesive or grout will not set on the surface of the tile causing cleaning difficulties later. This is particularly important when fixing tiles with a structured or non slip surface. When grouting tiles with a structured surface it is advisable to ensure grout does not get spread across the whole surface of the tile.

**Secondary Cleaning:**

Whilst thorough washing with clean water will remove residual adhesive and grout from the surface of the tile a proprietary acid based cleaning agent should be applied within 2-3 days of laying to completely clean the surface of the tile. When using secondary cleaning agents it is advisable to “test” the product on a loose tile first to ensure the surface shine and brilliance of the tile is not affected.Recommended Secondary Cleaning Detergents For Water Based Adhesive and Grout:

CLEANING CEMENT-BASED GROUT AFTER INSTALLATION	TYPE OF DETERGENT	PRODUCT	MANUFACTURER
	Acid detergent	CEMENT REMOVER	FABER CHIMICA
		KERANET	MAPEI
		DETERDEK	FILA

#### Recommended secondary Cleaning for Epoxy Grouted Floors:

When using epoxy grouts it is important to remember they harden much more quickly than conventional water based cement grouts. It is therefore necessary to carry out the cleaning procedures immediately using an alkaline detergent.

CLEANING EPOXY-BASED GROUT AFTER INSTALLATION	TYPE OF DETERGENT	PRODUCT	MANUFACTURER
	Alkaline detergent	EPOXY REMOVER	FABER CHIMICA
		FILA CR	10 FILA

#### B) EVERYDAY CLEANING AND MAINTENANCE:

For day to day general cleaning you should use any normal neutral detergent suitable for the cleaning of ceramic or porcelain tiles. Dilute with warm water and always follow the instructions on the product label.

## Conseils pour le stucage et le nettoyage après la pose

Le nettoyage final de l'éventuel voile poussiéreux de stuc de la surface doit être effectué à la fin du séchage du stuc en ciment (minimum 36 à 48 heures), en effectuant un nettoyage à partir d'un détergent acide applicable à la main (éponge ou chiffons) ou à la machine (mono brosse), en respectant scrupuleusement les conseils reportés ci-dessous.

### 1. Produits conseillés

Il est conseillé d'utiliser une solution acide à action tamponnée, diluée 1:5 (1 litre dans 5 d'eau chaude) dans de l'eau chaude si possible.

Quantité d'utilisation : 6 litres de solution acide pour 100m2.

Éviter absolument l'utilisation d'acides de quincaillerie dilués (pour leur relâchement de fumées nocives et pour leur action "brûlante" vis-à-vis des joints).

### 2. Modalité d'exécution

a - Mouiller avec de l'eau uniquement le stuc en ciment de manière à le protéger d'une éventuelle action corrosive de la solution acide diluée ;

b - Répartir uniformément la solution acide diluée en utilisant un balai à franges normal, un chiffon rugueux pour les environnements résidentiels ou en frictionnant à l'aide d'une mono-brosse rotative pour les grands surfaces ;

c - Laisser agir pendant quelques minutes en fonction de l'intensité de la saleté ;

d - Intervenir énergiquement à l'aide d'une éponge commerciale scotch-brïte ou à l'aide d'un balai-brosse;

e - Retirer le résidu avec des chiffons ou un aspirateur de liquides ;

f - Rincer abondamment avec de l'eau chaude propre en répétant l'opération plusieurs fois jusqu'à l'élimination de toutes les auréoles ou tous les résidus dans les interstices.

Un nettoyage minutieux et correct du produit en céramique est fondamental pour en préserver le brillant et la beauté d'origine. Il est donc recommandé de suivre avec attention les indications suivantes

#### A) NETTOYAGE “APRÈS LA POSE” SUR LE CHANTIER

#### Le lavage initial des carreaux au cours de la phase “après la pose” sur le chantier est une étape extrêmement importante.

En effet, c'est à ce moment-là qu'il est possible d'éliminer facilement des carreaux tous les résidus du matériel utilisé pour la pose et/ou du jointage des joints.

Il s'agit de résidus de différente nature qui pourraient s'avérer difficiles à éliminer par la suite, si on les laisse “sécher et/ou durcir” sur les carreaux, surtout s'ils sont caractérisés par une surface structurée plus ou moins accentuée. On recommande toujours de choisir le produit de nettoyage avec la plus grande attention pour ne pas altérer irrémédiablement le degré de luisance et de brillance du carreau posé.

#### Nettoyage des carrelages jointes avec des “Mastics à base de ciment et d'eau”

Comme on l'a dit, le lavage “après la pose” permet d'éliminer les résidus de béton, les mastics à base de ciments, les nitrates de potassium, les colles et les éventuels résidus superficiels de différente nature. Au cours de cette phase, le carrelage doit être lavé avec des détergents à base d'acides tamponnés au moins 3-4 jours après la pose et au maximum dans les 10 jours.

N.B. : Pour les produits caractérisés par des surfaces structurées et/ou antidérapantes, il est recommandé, vu les aspérités de la structure, de salir le moins possible la surface du carreau au cours de la pose et de bien éliminer les excès de produit utilisé immédiatement après le jointage avec une éponge imbibée d'eau propre. Il est également recommandé d'exécuter la procédure décrite ci-dessous dès que possible et au plus tard avant la période maximale de 3-4 jours indiquée plus haut à compter de l"“après-pose”.

**Procéder comme suit** :

- Préparer le détergent d'après les indications figurant sur l'étiquette (il est recommandé d'effectuer des essais préliminaires sur des carreaux non posés pour vérifier l'inaltérabilité de la surface des carreaux)
- Mouiller préalablement le carrelage avec de l'eau propre
- Étaler la solution sur les carreaux en laissant agir quelques minutes
- Passer la monobrosse en utilisant les disques appropriés (verts pour les surfaces structurées et rouges pour les surfaces non structurées) ou une paille de fer (verte pour les surfaces structurées et rouge/marron pour les surfaces non structurées) en frottant énergiquement la surface des carreaux.
- Rincer abondamment à l'eau propre en aspirant le liquide

NETTOYAGE FIN DE CHANTIER MORTIER À BASE DE CIMENT	TYPE DE DÉTERGENT	PRODUIT	FABRICANT
	Détergent acide	CEMENT REMOVER	FABER CHIMICA
		KERANET	MAPEI
		DETERDEK	FILA

#### Nettoyage des carrelages jointes avec des “Mastics époxy”

Si l'on utilise des mastics époxy, vu qu'ils durcissent rapidement en quelques minutes, le lavage “après la pose” doit être effectué avec des détergents alcalins dans les plus brefs délais en suivant scrupuleusement les indications et les procédures d'utilisation figurant sur l'étiquette.

**Procéder comme suit** :

- Préparer le détergent d'après les indications figurant sur l'étiquette (il est recommandé d'effectuer des essais préliminaires sur des carreaux non posés pour vérifier l'inaltérabilité de la surface des carreaux)
- Mouiller préalablement le carrelage avec de l'eau propre
- Étaler la solution sur les carreaux en laissant agir quelques minutes
- Passer la monobrosse en utilisant les disques appropriés (verts pour les surfaces structurées et rouges pour les surfaces non structurées) ou une paille de fer (verte pour les surfaces structurées et rouge/marron pour les surfaces non structurées) en frottant énergiquement la surface des carreaux.
- Rincer abondamment à l'eau propre en aspirant le liquide

NETTOYAGE FIN DE CHANTIER MORTIER ÉPOXY	TYPE DE DÉTERGENT	PRODUIT	FABRICANT
	Détergent alcalin	EPOXY REMOVER	FABER CHIMICA
		FILA CR	10 FILA

#### B) NETTOYAGE QUOTIDIEN

Le nettoyage quotidien peut être réalisé à l'aide de détergents neutres normaux indiqués pour le nettoyage des surfaces en céramique, éventuellement en les diluant dans de l'eau chaude pour en augmenter l'efficacité, en suivant les instructions du producteur sur l'étiquette.

## Ratschläge für die verfugung und erste reinigung nach der verlegung

Auströcknung des Fugenmörtels (mindestens 36-38 Stunden) erfolgen;

Die Reinigung ist mit einem säurehaltigen Putzmittel per Hand oder maschinell (mit Monobürste) entsprechend den folgenden Anweisungen auszuführen.

#### 1. Empfohlene Produkte

Wir empfehlen die Verwendung einer Säurelösung mit tamponierender Wirkung, verdünnt im Verhältnis1:5 ( 1 Liter Lösung ,mit 5 Liter Warmwasser)

Verwendungsmenge: 6 Liter Säurelösung per 100 qm.

Die Verwendung von verdünnten Eisensäuren sind absolut zu vermeiden, aufgrund von Entstehung schädlicher Ausdünstungen und Beschädigung der Fugen.

#### 2. Verarbeitungssanweisung

a - nur die Fugen mit Wasser annässen zum Schutz vor einer evtl. Korrosiven Wirkung der verdünnten Säurelösung.

b - Die Säurelösung gleichmäßig auf der Verarbeitungsfläche verteilen unter Verwendung haushaltsüblicher Bodenreinigungsgeräte oder eines rauen Lappen oder reibend mit einer für große Flächen geeigneten drehenden Bürste.

c - Einige Minuten lang einwirken lassen - je nach der Schmutzdichte.

d - Verwenden Sie zur Reinigung z.B. einen „SCOTCH-BRITE“-Schwamm oder eine große Bürste.

e - Die Reste mit Lappen oder Flüssigkeitsaugern aufnehmen.

f - Reichlich mit klaren Wasser nachspülen, das Verfahren mehrmals auf der gesamtmen . Fläche wiederholen.

Die richtige Reinigung der Keramik Erzeugnisse ist äußerst wichtig, damit sie lange schön bleiben und ihre ursprüngliche Optik bewahrt wird. Daher empfehlen wir folgende Vorgehensweise:

#### A) REINIGUNG NACH DER VERLEGUNG/ERSTREINIGUNG ODER BAUENDREINIGUNG.

#### Die erste Reinigung der Fliesen nach der Verlegung ist von wesentlicher Bedeutung

Zu diesem Zeitpunkt ist es noch möglich, sämtliche Materialreste der Verlege- und/oder Verfugungsarbeiten mühelos von den Fliesen zu entfernen. Lässt man diese Überreste verschiedener Art auf den Fliesen eintrocknen, so kann es sein, das diese sich vor allem bei einer stärker strukturierter Oberfläche, zu einem späteren Zeitpunkt nur noch sehr schwer beseitigen lassen. Auch das Reinigungsmittel sollte mit größter Sorgfalt ausgewählt werden, um zu vermeiden, dass die strahlende Optik der verlegten Fliesen nicht unwiederbringlich verloren geht.

#### Reinigung von Fußböden, die mit „Zementfugenmörtel auf Wasserbasis“ verfugt sind“

Wie bereits erwähnt, werden bei der Erstreinigung nach der Verlegung sämtliche Reste an Zement, Zementfugenmasse, Salpeter und Klebstoffen entfernt, ebenso wie eventuelle oberflächliche Materialreste verschiedener Art. Der Boden sollte innerhalb von 3-4 Tagen, jedoch spätestens 10 Tage nach der Verlegung mit einem schonenden und handelsüblichen Bauendreiniger gereinigt werden. Für empfindliche Oberflächen kann auch ein schonender Bauendreiniger für Marmor eingesetzt werden. Hier kann keine Verletzung der Oberfläche eintreten. Informieren Sie sich im Fachhandel und beachten Sie die Herstellerangaben.

Hinweis: Bei den Erzeugnissen mit strukturierter und/oder rutschfester Oberfläche wird aufgrund der rauen Struktur empfohlen, die Oberfläche während der Verlegung so wenig wie möglich zu beschmutzen und das überschüssige Material nach den Verfugungsarbeiten sofort mit einem in sauberem Wasser getränkten Schwamm zu reinigen. Außerdem sollten die unten beschriebenen Arbeiten so früh wie möglich und in jedem Fall vor der oben genannten Frist von 3-4 Tagen nach der Verlegung durchgeführt werden.

**Folgende Vorgehensweise empfehlen wir:**

- Das Reinigungsmittel gemäß den Hinweisen auf dem Etikett verarbeiten (es wird empfohlen, vorher Proben an nicht verlegten Fliesen durchzuführen, um sicherzustellen, ob die Oberfläche nicht verändert wird).
- Der Belag wird mit klarem Wasser vorgenässt.
- Das Reinigungsmittel wird auf den Belag aufgebracht. Beachten Sie die Herstellerangaben für die Einwirkzeit. Bei zu langen Einwirkzeiten können Verätzungen auftreten.
- Je nach Oberflächenstruktur können Sie zur manuellen Unterstützung, Bürsten oder Pads verwenden. Das gleiche gilt auch im Einsatz mit Reinigungsautomaten oder Einscheibenmaschinen. Aber bitte Vorsicht! Achten Sie auf die Härtegrade der Pads. Ihr Fachhändler wird Sie hinreichend aufklären. Zu harte Pads können die Oberfläche schädigen. Weichere Bürsten oder weiße/weiche Pads sind daher immer eine gute Wahl.
- Die Schmutzbrühe anschließend aufnehmen und gründlich mit klarem Wasser nachwaschen.

REINIGUNG DES ZEMENTBASIS NACH DER INSTALLATION	WASCHMITTEL	PRODUKT	HERSTELLER
	Säurewaschmittel	CEMENT REMOVER	FABER CHIMICA
		KERANET	MAPEI
		DETERDEK	FILA

#### Reinigung von Fußböden, die mit „Epoxidfugenmörtel“ verfugt sind:

Bei der Verwendung von Epoxidfugenmörtel, der bereits innerhalb weniger Minuten hart wird, muss die Erstreinigung schnellstmöglich nach der Verlegung mit geeigneten Reinigungsmitteln erfolgen, wobei die auf dem Etikett genannten Hinweise und Anwendungsverfahren unbedingt befolgt werden sollten.

REINIGUNG EPOXY-BASIERTER FUGEN NACH INSTALLATION	WASCHMITTEL	PRODUKT	HERSTELLER
	Alkalisches Reinigungsmittel	EPOXY REMOVER	FABER CHIMICA
		FILA CR	10 FILA

#### B) TÄGLICHE REINIGUNG/UNTERHALTSREINIGUNG

Für die Unterhaltsreinigung empfehlen wir handelsübliche Feinsteinzeugreiniger. Informieren Sie sich im Fachhandel und beachten Sie die Herstellerangaben.

## NOTE TECNICHE serie MANHATTAN

#### DESTINAZIONI D'USO CONSIGLIATE

Non utilizzabili per rivestimenti esterni / vasche piscina / o fontane.

#### INDICAZIONI PER LA POSA

Verificare la corretta planarità del supporto ed eventualmente livellare la superficie prima della posa, trattandosi di un prodotto altamente artigianale verificare che non sia presente umidità residua prima della posa (nel caso lasciarlo asciugare completamente), scegliere l'adesivo in funzione del tipo di supporto e seguire le istruzioni di utilizzo indicate dal produttore. Non Bagnare le piastrelle prima o durante la posa. Tali finiture possono essere applicati con l'utilizzo di adesivi cementizi classe C2 E, o adesivi reattivi classe R2 (da verificare a seconda delle caratteristiche del supporto). La differenza di tonalità fra le piastrelle di colore e tono non è da considerarsi difetto ma bensì caratteristica di manufatti altamente artigianali. Pertanto, nella posa, si suggerisce di attingere da più scatole contemporaneamente per ottenere un miglior risultato estetico. Prima di posare il prodotto, si consiglia di verificare le caratteristiche dimensionali (soprattutto spessore, rettilineità e planarità), seguendo sempre le norme tecnico-estetiche per una posa eseguita “a regola d’arte”. Si suggerisce di lasciare una fuga minima di 2/3 mm, lo stucco dovrà essere di natura cementizia (si sconsigliano stucchi reattivi) asportato rapidamente durante le fasi di applicazioni per evitare eventuali residui.

#### INDICAZIONI PER LA MANUTENZIONE STRAORDINARIA O FINE CANTIERE

PER IL LAVAGGIO E IL TRATTAMENTO DI FINE CANTIERE, SI AVVERTE DI NON UTILIZZARE DETERGENTI ACIDI.

Ripulire la superficie effettuando un lavaggio con una soluzione acquosa ottenuta diluendo detergenti neutri (tipo FILACLEANER di Fila). Effettuare il primo passaggio utilizzando una spugna o un tampone bianco per poi risciacquare con acqua.

#### INDICAZIONI PER LA MANUTENZIONE ORDINARIA

Evitare prodotti detergenti aggressivi e abrasivi (PRODOTTI ANTI-CALCARE, SPUGNE ABRASIVE, ECC.). Si consiglia l’impiego di prodotti a base neutra normalmente reperibili in commercio. Si avverte che mettere a contatto piastrelle Manhattan (dotate di texture craquelé) con acqua,sostanze e materiali sporchi o untuosi può rovinare l’effetto craquelé della superficie.



FILA Industria Chimica SPA
Via Garibaldi, 32- 35018- San Martino di Lupari (PD)
Tel. 049/9467300 Fax 049/9460753
info@filachim.com
www.@filachim.com

## AVVERTENZE PER FINITURA CRAQUELÉ

#### LAVAGGIO INIZIALE

Prodotto: **FILACLEANER** diluito in acqua 1:10

Attrezzatura: Straccio morbido o panno spugna

Modalità: Aspirare o rimuovere manualmente tutta la polvere di cantiere. Lavare con la soluzione di detergente utilizzando un panno o una spugna morbida. Si consiglia di ripassare con uno straccio asciutto per asciugare la superficie lasciandola perfettamente lucida.

**ATTENZIONE: Non usare prodotti acidi per la pulizia dello sporco di posa**, lo smalto potrebbe venire danneggiato. In fase di posa si dovrà porre la massima attenzione per lasciare il materiale il più pulito possibile, spugnando con abbondante acqua pulita.

#### Protezione antimacchia

Si informa che la protezione antimacchia è già presente sul materiale acquistato ma, per una corretta manutenzione del prodotto,

sono consigliate successive applicazioni ogni 2 anni, con il seguente prodotto: **FILA MP/90**

Attrezzatura: Pennellessa o spugna

Modalità: Applicare una mano di protettivo con pennellessa morbida o spugna, in modo uniforme e continuo, impregnando anche le fughe. Il materiale dovrà risultare bagnato da un velo leggero di prodotto. Lasciare asciugare 24 ore circa, quindi rimuovere l’eccesso di prodotto non assorbito, con un panno imbevuto dello stesso prodotto oppure di FILASOLV.

Strofinare per rimuovere il residuo e asciugare con un altro panno asciutto.

#### MANUTENZIONE ORDINARIA

Prodotto: FILACLEANER diluito 1:200

Attrezzatura: Panno spugna morbido

Modalità: Lavare la superficie con il panno sciacquato spesso e nella soluzione di detergente e ben strizzato.

#### ATTENZIONE: Sostanze come aceto, succhi di frutta, coca cola, vino, ecc. possono danneggiare il materiale anche se protetto.

Le modalità d'uso e le procedure d'applicazione dei prodotti consigliati sono il risultato di precise verifiche da parte del laboratorio. Esistono comunque dei fattori che sfuggono alla nostra influenza: stato della superficie prima del trattamento, caratteristiche/finiture del materiale particolarmente rare o non specificate, condizioni ambientali, professionalità dell'utilizzatore. Si raccomanda perciò una prova preliminare sulla superficie da trattare. La Fila garantisce sempre la qualità dei suoi prodotti ma non si assume alcuna responsabilità per un loro impiego scorretto.

SUPERFICI LAPPATE			
PULIZIA FINE CANTIERE STUCCO CEMENTIZIO	TIPO DI DETERGENTE	PRODOTTO	PRODUTTORE
	Detergente acido	TILE CLEANER	FABER CHIMICA
		FILA CLEANER	FILA
		FLOOR CLEANER	FABER CHIMICA
PROCEDURA *	Per stucchi cementizi additivati con resine o lattici occorre effettuare la rimozione subito con spugna e abbondante acqua. Lavare con una soluzione di detergente leggermente acido o neutro, diluito in acqua secondo le modalità comunicate dal fabbricante, mediante monospazzola o spazzola in saggina, frizionare energicamente. Risciacquare abbondantemente con acqua pulita rimuovendo completamente il liquido tramite spatola gommata e stracci o aspiraliquidi. Ripetere il lavaggio e il risciacquo per due volte con acqua pulita e quindi lasciare asciugare accuratamente.		
PULIZIA FINE CANTIERE STUCCO EPOSSIDICO	TIPO DI DETERGENTE	PRODOTTO	PRODUTTORE
	Detergente alcalino	EPOXY REMOVER	FABER CHIMICA
		FILA CR 10	FILA
PROCEDURA *	Per stucchi epossidici la rimozione deve essere fatta immediatamente con spugna e abbondante acqua. Il giorno successivo alla stuccatura lavare la pavimentazione con soluzione a base di detergente alcalino, diluito in acqua secondo le indicazioni comunicate dal fabbricante, per mezzo di monospazzola o spazzola in saggina frizionando energicamente. Risciacquare abbondantemente con acqua pulita asportando completamente il liquido tramite spatola gommata e stracci o aspiraliquidi. Ripetere il lavaggio e il risciacquo con acqua pulita per due volte e quindi lasciare asciugare accuratamente. Se dovessero rimanere residui traslucidi di stucco utilizzare un solvente idoneo come può essere un diluente al nitro.		
PULIZIA CONSIGLIATA PRIMA DI ARREDARE I LOCALI	TIPO DI DETERGENTE	PRODOTTO	PRODUTTORE
	Detergente leggermente acido o neutro	TILE CLEANER	FABER CHIMICA
		FILA CLEANER	FILA
		FLOOR CLEANER	FABER CHIMICA
PROCEDURA *	Lavare la pavimentazione con soluzione di detergente leggermente acido o detergente neutro, diluito in acqua secondo le indicazioni comunicate dal fabbricante, mediante monospazzola o spazzola in saggina frizionando energicamente. Risciacquare abbondantemente con acqua pulita rimuovendo completamente il liquido tramite spatola gommata e stracci o aspiraliquidi. Ripetere il lavaggio e il risciacquo con acqua pulita per due volte e quindi lasciare asciugare accuratamente.		
MANUTENZIONE ORDINARIA	TIPO DI DETERGENTE	PRODOTTO	PRODUTTORE
	Detergente neutro	FILA CLEANER	FILA
		FLOOR CLEANER	FABER CHIMICA
PROCEDURA *	Lavare il pavimento con detergenti neutri diluiti in acqua seguendo le istruzioni comunicate dal fabbricante. Non utilizzare prodotti con cere o additivi lucidanti. Sciacquare abbondantemente con acqua pulita e quindi lasciare asciugare accuratamente.		
RIMOZIONE MACCHIE COLORATE (vino, frutta, caffè, nicotina)	TIPO DI DETERGENTE	PRODOTTO	PRODUTTORE
	Detergente polifunzionale	COLORED STAIN REMOVER	FABER CHIMICA
		PS 87	FILA
PROCEDURA *	Utilizzare secondo le concentrazioni indicate dal fabbricante, direttamente sulla macchia, lasciare agire secondo i tempi indicati dal fabbricante, e risciacquare la superficie. Se la macchia dovesse persistere ripetere l'operazione.		
RIMOZIONE DI SOSTANZE GRASSE	TIPO DI DETERGENTE	PRODOTTO	PRODUTTORE
	Detergente polifunzionale	OIL & GREASE REMOVER	FABER CHIMICA
		PS 87	FILA
PROCEDURA *	Utilizzare secondo le concentrazioni indicate dal fabbricante direttamente sulla macchia, lasciare agire secondo i tempi suggeriti e asportare il residuo con spugna umida. Se la macchia dovesse persistere ripetere l'operazione.		

SUPERFICI NATURALI E STRUTTURATE			
PULIZIA FINE CANTIERE STUCCO CEMENTIZIO	TIPO DI DETERGENTE	PRODOTTO	PRODUTTORE
	Detergente acido	CEMENT REMOVER	FABER CHIMICA
		KERANET	MAPEI
		DETERDEK	FILA
PROCEDURA *	Per stucchi cementizi additivati con resine o lattici occorre effettuare la rimozione subito con spugna e risciacquare abbondantemente. Utilizzare a stucco indurito, mai oltre 7 giorni, un detergente acido post posa diluito in acqua seguendo le modalità comunicate dal fabbricante mediante monospazzola o spazzola in saggina e frizionare. Sciacquare abbondantemente con acqua pulita, rimuovendo completamente il liquido tramite spatola gommata e stracci puliti o aspiraliquidi. Ripetere il lavaggio e il risciacquo con acqua pulita per due volte e quindi lasciare asciugare accuratamente.		
PULIZIA FINE CANTIERE STUCCO EPOSSIDICO	TIPO DI DETERGENTE	PRODOTTO	PRODUTTORE
	Detergente alcalino	EPOXY REMOVER	FABER CHIMICA
		FILA CR 10	FILA
PROCEDURA *	Lavare il pavimento con soluzione detergente leggermente acida o neutra, diluita in acqua secondo le indicazioni comunicate dal fabbricante, mediante monospazzola o spazzola in saggina frizionando energicamente. Sciacquare abbondantemente con acqua pulita, rimuovendo completamente il liquido tramite spatola gommata e stracci puliti o aspiraliquidi. Ripetere il lavaggio e il risciacquo con acqua pulita per due volte e quindi lasciare asciugare accuratamente.		
MANUTENZIONE ORDINARIA	TIPO DI DETERGENTE	PRODOTTO	PRODUTTORE
	Detergente neutro	FILA CLEANER	FILA
		FLOOR CLEANER	FABER CHIMICA
PROCEDURA *	Utilizzare secondo le concentrazioni comunicate dal fabbricante, direttamente sulla macchia, lasciare agire secondo i tempi indicati dal fabbricante, e risciacquare la superficie con acqua pulita. Se la macchia dovesse persistere ripetere l'operazione.		
RIMOZIONE MACCHIE COLORATE (vino, frutta, caffè, nicotina)	TIPO DI DETERGENTE	PRODOTTO	PRODUTTORE
	Detergente polifunzionale	COLORED STAIN REMOVER	FABER CHIMICA
		PS 87	FILA
PROCEDURA *	Utilizzare secondo le concentrazioni indicate dal fabbricante, direttamente sulla macchia, lasciare agire secondo i tempi indicati dal fabbricante, e risciacquare la superficie. Se la macchia dovesse persistere ripetere l'operazione.		
RIMOZIONE DI ALONATURE LUCIDE /OPACHE	TIPO DI DETERGENTE	PRODOTTO	PRODUTTORE
	Detergente polifunzionale	TILE CLEANER	FABER CHIMICA
		PS 87	FILA
PROCEDURA *	Utilizzare secondo le concentrazioni comunicate dal fabbricante direttamente sulla macchia, lasciare agire secondo i tempi suggeriti e rimuovere il residuo con spugna umida. Se la macchia dovesse persistere ripetere l'operazione.		

Nel caso di **residui di sporco non rimovibili** con detergenti di uso comune si consiglia di consultare la tabella sottostante:

TIPO DI SPORCO	SOLUZIONE	DETERGENTI	PRODUTTORE
MACCHIE INORGANICHE			
carbone - efflorescenze calcaree - gesso - segni metallici - ruggine - matita (grafite) - tempere naturali	ACIDA	DETERDEK TILE CLEANER	Fila Industria Chimica S.p.A. Faber Chimica
MACCHIE ORGANICHE			
Tracce di gomma (suole,pneumatici)	ALCALINA	FILA PS/87 TILE CLEANER	Fila Industria Chimica S.p.A. Faber Chimica
coca cola - caffè - vino - birra - gelato - oli e grassi animali e vegetali - mostarda - ketchup - maionese - marmellata - tintura per capelli - shampoo - rossetto - chewing-gum - inchiostri lampostil	ALCALINA	FILA PS/87 TILE CLEANER	Fila Industria Chimica S.p.A. Faber Chimica
MACCHIE SINTETICHE			
oli silicologici e meccanici - silicone - resine - smalti - lacche - bitume - cera di candele - vernice - catrame - caucciù - residui di scotch	SOLVENTE	FILASOLV ACETONE DILUENTE NITRO	Fila Industria Chimica S.p.A. In Commercio In Commercio
CASI PARTICOLARI			
TIPO DI SPORCO	DETERGENTI	MODO OPERATIVO	
MACCHIE PARTICOLARI			
rimozione di cere protettive	DETERDEK (Fila) TILE CLEANER (Faber)	Per l'eliminazione dei residui di cera, compiere il lavaggio acido strofinando energicamente con tampone scotch-brite fino a completa eliminazione del materiale solido. Nel caso in cui dovessero rimanere alonature silicologiche, distribuire filasolv, lasciando agire fino a completa evaporazione. Risciacquare abbondantemente con acqua calda pulita.	
alonature rotonde delle ventose	FILA HOBBY (Fila) PS/87 (Fila)	Spruzzare con l'apposito spruzzo (per fila hobby) il detergente sulla piastrina che presenta l'alone. Lasciare agire per qualche secondo (mai fino ad asciugamento completo), strofinare energicamente con tampone scotch-brite inumidito e risciacquare abbondantemente con acqua calda pulita.	
MACCHIE RESISTENTI			
tutte le macchie inorganiche (vedi sopra) che non vengono rimosse con DETERDEK	PH ZERO (Fila Industria Chimica)	Ph zero è un acido piu' forte del deterdek e pertanto la sua azione è piu' aggressiva verso le macchie di natura inorganica. Da usare solo in casi giudicati estremi e dopo aver provato, anche piu' volte, con deterdek.	
tutte le macchie organiche (vedi sopra) che non vengono rimosse con PS/87	DRASTIC (Fila Industria Chimica)	Drastic è un prodotto alcalino piu' forte del ps/87 e pertanto la sua azione è piu' aggressiva verso le macchie di natura organica. Da usare solo in casi giudicati estremi e dopo aver provato, anche piu' volte, con ps/87.	

## Cleaning and care of Tuscania products

LAPPED SURFACES			
CLEANING CEMENT-BASED GROUT AFTER INSTALLATION	TYPE OF DETERGENT	PRODUCT	MANUFACTURER
	Acid detergent	TILE CLEANER	FABER CHIMICA
		FILA CLEANER	FILA
		FLOOR CLEANER	FABER CHIMICA
PROCEDURE *	Residues of cement-based grouts containing resin or latex must be removed immediately with a sponge. Rinse with plenty of water. Wash with a mildly acid or neutral cleaning solution, diluted in water as indicated by the manufacturer. Rub vigorously with a motorised brush or broom. Rinse thoroughly with clean water. Soak up liquid with a rubber-coated squeegee, clean cloths or liquid remover. Repeat cleaning and rinse twice with clean water. Allow to dry.		
CLEANING EPOXY-BASED GROUT AFTER INSTALLATION	TYPE OF DETERGENT	PRODUCT	MANUFACTURER
	Alkaline detergent	EPOXY REMOVER	FABER CHIMICA
		FILA CR 10	FILA
PROCEDURE *	Epoxy-based grout must be removed immediately with a sponge. Rinse with plenty of water. The day of grouting, wash the floor with an alkaline detergent, diluted as indicated by the manufacturer. Rub vigorously with a motorised brush or broom. Rinse thoroughly with clean water. Soak up liquid with a rubber-coated squeegee, clean cloths or liquid remover. Repeat cleaning and rinse twice with clean water. Allow to dry. If grout stains remain, use a suitable solvent, such as a nitro thinner.		
RECOMMENDED CLEANING BEFORE FURNISHING ROOMS	TYPE OF DETERGENT	PRODUCT	MANUFACTURER
	Mildly acid or neutral detergent	TILE CLEANER	FABER CHIMICA
		FILA CLEANER	FILA
		FLOOR CLEANER	FABER CHIMICA
PROCEDURE *	Wash the floor with a mildly acid or neutral cleaning solution, diluted in water as indicated by the manufacturer. Rub vigorously with a motorised brush or broom. Rinse thoroughly with clean water. Soak up liquid with a rubber-coated squeegee, clean cloths or liquid remover. Repeat cleaning and rinse twice with clean water. Allow to dry.		
ROUTINE CARE	TYPE OF DETERGENT	PRODUCT	MANUFACTURER
	Neutral detergent	FILA CLEANER	FILA
		FLOOR CLEANER	FABER CHIMICA
PROCEDURE *	Wash the floor with a neutral detergent, diluted in water as indicated by the manufacturer. Never use wax-based products or glossenhancers. Rinse thoroughly with clean water and allow to dry.		
REMOVAL OF COLOURED STAINS (wine, fruit, coffee, nicotine)	TYPE OF DETERGENT	PRODUCT	MANUFACTURER
	Multipurpose detergent	COLORED STAIN REMOVER	FABER CHIMICA
		PS 87	FILA
PROCEDURE *	Apply directly to the stain and allow to soak, for the time and in the concentration indicated by the manufacturer. Then rinse the surface. If the stain remains, repeat.		
REMOVAL OF GREASY SUBSTANCES	TYPE OF DETERGENT	PRODUCT	MANUFACTURER
	Multipurpose detergent	OIL & GREASE REMOVER	FABER CHIMICA
		PS 87	FILA
PROCEDURE *	Apply directly to the stain and allow to soak, for the time and in the concentration indicated by the manufacturer. Remove residue with a moist sponge. If the stain remains, repeat.		

NATURAL AND TEXTURED SURFACES			
CLEANING CEMENT-BASED GROUT AFTER INSTALLATION	TYPE OF DETERGENT	PRODUCT	MANUFACTURER
	Acid detergent	CEMENT REMOVER	FABER CHIMICA
		KERANET	MAPEI
		DETERDEK	FILA
PROCEDURE *	Residues of cement-based grouts containing resin or latex must be removed immediately with a sponge. Rinse with plenty of water. To remove hardened grout (within 7 days from installation), use an acid detergent for after-installation cleaning, diluted in water in accordance to the manufacturer's instructions. Apply and rub with a motorised brush or broom. Rinse thoroughly with clean water. Soak up liquid with a rubber-coated squeegee, clean cloths or liquid remover. Repeat cleaning and rinse twice with clean water. Allow to dry.		
CLEANING EPOXY-BASED GROUT AFTER INSTALLATION	TYPE OF DETERGENT	PRODUCT	MANUFACTURER
	Alkaline detergent	EPOXY REMOVER	FABER CHIMICA
		FILA CR 10	FILA
PROCEDURE *	Wash the floor with a mildly acid or neutral cleaning solution, diluted in water as indicated by the manufacturer. Rub vigorously with a motorised brush or broom. Rinse thoroughly with clean water. Soak up liquid with a rubber-coated squeegee, clean cloths or liquid remover. Repeat cleaning and rinse twice with clean water. Allow to dry.		
ROUTINE CARE	TYPE OF DETERGENT	PRODUCT	MANUFACTURER
	Neutral detergent	FILA CLEANER	FILA
		FLOOR CLEANER	FABER CHIMICA
PROCEDURE *	Wash the floor with a neutral detergent, diluted in water as indicated by the manufacturer. Never use wax-based products or gloss-enhancers. Rinse thoroughly with clean water and allow to dry.		
REMOVAL OF COLOURED STAINS (wine, fruit, coffee, nicotine)	TYPE OF DETERGENT	PRODUCT	MANUFACTURER
	Multipurpose detergent	COLORED STAIN REMOVER	FABER CHIMICA
		PS 87	FILA
PROCEDURE *	Apply directly to the stain and allow to soak, for the time and in the concentration indicated by the manufacturer. Rinse thoroughly with clean water. If the stain remains, repeat.		
REMOVING GLOSSY / MATT MARK	TYPE OF DETERGENT	PRODUCT	MANUFACTURER
	Multipurpose detergent	TILE CLEANER	FABER CHIMICA
		PS 87	FILA
PROCEDURE *	Apply directly to the stain and allow to soak, for the time and in the concentration indicated by the manufacturer. Remove residue with a moist sponge. If the stain remains, repeat.		
<b>If dirt residue cannot be removed using standard detergents, refer to the following table:</b>			
TYPE OF DIRT	SOLUTION	DETERGENTS	MANUFACTURER
INORGANIC STAINS			
coal, lime efflorescence, plaster, metallic marks, rust, pencil (graphite), natural paints.	ACID	DETERDEK TILE CLEANER	Fila Industria Chimica S.p.A. Faber Chimica
ORGANIC STAINS			
traces of rubber (soles of shoes, tyres)	ALKALINE	FILA PS/87 TILE CLEANER	Fila Industria Chimica S.p.A. Faber Chimica
coca cola, coffee, wine, beer, ice-cream, animal and vegetable oils and fats, mustard, ketchup, mayonnaise, jam, hair dye, shampoo, lipstick, chewing-gum, marker pen ink	ALKALINE	FILA PS/87 TILE CLEANER	Fila Industria Chimica S.p.A. Faber Chimica
SYNTHETIC STAINS			
silicone and machine oils, silicone, resins, varnish, lacquer, bitumen, candle wax, paint, tar, india rubber, adhesive tape residues	SOLVENT	FILASOLV ACETONE DILUENTE NITRO	Fila Industria Chimica S.p.A. In Commercio In Commercio
SPECIFIC CASES			
TYPE OF DIRT	DETERGENTS	CLEANING METHOD	
SPECIFIC STAINS			
remove of protective waxes	DETERDEK (Fila) TILE CLEANER (Faber)	For the elimination of wax residues use acid cleaning, scrubbing vigorously with a scotch-brite buffer until complete removal of the solid material. If silicone haloes remain, apply filasolv, leaving it to act until it has completely evaporated. Rinse thoroughly with hot, clean water.	
round suction cap marks	FILA HOBBY (Fila) PS/87 (Fila)	Use the specific nozzle (for fila hobby) to spray the detergent onto the marked tile and leave to act for a few seconds (never until completely dry). Scrub vigorously with a damp scotch-brite buffer and rinse thoroughly with hot, clean water.	
RESISTANT STAINS			
all inorganic stains (see above) not removed with DETERDEK	PH ZERO (Fila Industria Chimica)	Ph zero is a stronger acid than deterdek and therefore has a more aggressive action against inorganic stains. Only for use in cases which are deemed to be extreme, after trying repeatedly with deterdek.	
all organic stains (see above) not removed with PS/87	DRASTIC (Fila Industria Chimica)	Drastic is a stronger alkaline product than ps/87 and so has a more aggressive action against organic stains. Only for use in cases which are deemed to be extreme, after trying repeatedly with PS87.	

Detergent manufacturers: FILA (Padova): Tel. +39 049 9467300 - Fax +39 049 9460753 - fila@filachim.it - www.filachim.com - FABER CHIMICA s.r.l. (Ancona): Tel. +39 073 2627178 - Fax +39 073 222935 - www.faberchimica.com



## Nettoyage et entretien des articles Tuscania

SURFACES LAPPATE			
NETTOYAGE FIN DE CHANTIER MORTIER À BASE DE CIMENT	TYPE DE DÉTERGENT	PRODUIT	FABRICANT
	Détergent acide	TILE CLEANER	FABER CHIMICA
		FILA CLEANER	FILA
		FLOOR CLEANER	FABER CHIMICA
PROCÉDURE *	Pour les mortiers à base de ciment additionnés de résines ou de latex, éliminer tout de suite à l'aide d'une éponge et à grande eau. Nettoyer à l'aide d'une solution détergente légèrement acide ou neutre, diluée selon les indications du fabricant, et d'une monobrosse ou d'une brosse à chiendent en frottant énergiquement. Rincer abondamment à l'eau propre pour éliminer complètement le liquide à l'aide d'une raclette caoutchoutée et de chiffons ou d'un aspirateur pour liquides. Répéter deux fois le lavage et le rinçage à l'eau claire puis laisser sécher soigneusement.		
NETTOYAGE FIN DE CHANTIER MORTIER ÉPOXY	TYPE DE DÉTERGENT	PRODUIT	FABRICANT
	Détergent alcalin	EPOXY REMOVER	FABER CHIMICA
		FILA CR 10	FILA
PROCÉDURE *	Pour les mortiers époxy, éliminer immédiatement la tache à l'aide d'une éponge et à grande eau. Le jour suivant le masticage, laver le sol à l'aide d'une solution à base de détergent alcalin, dilué avec de l'eau selon les indications du fabricant, et d'une monobrosse ou d'une brosse à chiendent en frottant énergiquement. Rincer abondamment à l'eau propre pour éliminer complètement le liquide à l'aide d'une raclette caoutchoutée et de chiffons ou d'un aspirateur pour liquides. Répéter deux fois le lavage et le rinçage à l'eau claire puis laisser sécher soigneusement. En présence de résidus translucides de mortier, utiliser un solvant approprié comme un diluant nitro.		
NETTOYAGE CONSEILLÉ AVANT L'AMEUBLEMENT	TYPE DE DÉTERGENT	PRODUIT	FABRICANT
	Détergent légèrement acide ou neutre	TILE CLEANER	FABER CHIMICA
		FILA CLEANER	FILA
		FLOOR CLEANER	FABER CHIMICA
PROCÉDURE *	Nettoyer le sol à l'aide d'une solution détergente légèrement acide ou d'un détergent neutre, diluée dans de l'eau selon les indications du fabricant, et d'une monobrosse ou d'une brosse à chiendent en frottant énergiquement. Rincer abondamment à l'eau claire et éliminer complètement le liquide à l'aide d'une raclette caoutchoutée, de chiffons ou d'un aspirateur pour liquides. Répéter deux fois le lavage et le rinçage à l'eau claire puis laisser sécher soigneusement.		
ENTRETIEN COURANT	TYPE DE DÉTERGENT	PRODUIT	FABRICANT
	Détergent neutre	FILA CLEANER	FILA
		FLOOR CLEANER	FABER CHIMICA
PROCÉDURE *	Nettoyer le sol à l'aide de détergents neutres dilués avec de l'eau selon les instructions du fabricant. Ne pas utiliser de produits contenant des cires ni des additifs brillants. Rincer abondamment à l'eau claire puis laisser sécher soigneusement.		
ÉLIMINATION TACHES COLORÉES (vin, fruits, café, nicotine)	TYPE DE DÉTERGENT	PRODUIT	FABRICANT
	Détergent multifonction	COLORED STAIN REMOVER	FABER CHIMICA
		PS 87	FILA
PROCÉDURE *	Utiliser selon le dosage indiqué par le fabricant directement sur la tache, laisser agir le temps indiqué puis rincer la surface. Si la tache persiste, répéter l'opération.		
ÉLIMINATION DE SUBSTANCES GRASSES	TYPE DE DÉTERGENT	PRODUIT	FABRICANT
	Détergent multifonction	OIL & GREASE REMOVER	FABER CHIMICA
		PS 87	FILA
PROCÉDURE *	Utiliser selon le dosage indiqué par le fabricant directement sur la tache, laisser agir le temps indiqué puis éliminer le résidu avec une éponge humide. Si la tache persiste, répéter l'opération.		

SURFACES NATURELLES STRUCTURÉES			
NETTOYAGE FIN DE CHANTIER MORTIER À BASE DE CIMENT	TYPE DE DÉTERGENT	PRODUIT	FABRICANT
	Détergent acide	CEMENT REMOVER	FABER CHIMICA
		KERANET	MAPEI
		DETERDEK	FILA
PROCÉDURE *	Pour les mortiers de jointoiement à base de ciment additionnés de résines ou de latex, éliminer tout de suite à l'aide d'une éponge et rincer abondamment. Après durcissement du mortier - mais jamais au-delà de 7 jours – utiliser un détergent acide après pose dilué avec de l'eau selon les modalités indiquées par le fabricant à l'aide d'une monobrosse ou d'une brosse à chiendent et frotter. Rincer abondamment à l'eau claire pour éliminer complètement le liquide à l'aide d'une raclette caoutchoutée et de chiffons propres ou d'un aspirateur pour liquides. Répéter deux fois le lavage et le rinçage à l'eau claire puis laisser sécher soigneusement.		
NETTOYAGE FIN DE CHANTIER MORTIER ÉPOXY	TYPE DE DÉTERGENT	PRODUIT	FABRICANT
	Détergent alcalin	EPOXY REMOVER	FABER CHIMICA
		FILA CR 10	FILA
PROCÉDURE *	Nettoyer le sol à l'aide d'une solution détergente légèrement acide ou neutre, diluée selon les indications du fabricant, et d'une monobrosse ou d'une brosse à chiendent en frottant énergiquement. Rincer abondamment à l'eau claire pour éliminer complètement le liquide à l'aide d'une raclette caoutchoutée et de chiffons propres ou d'un aspirateur pour liquides. Répéter deux fois le lavage et le rinçage à l'eau claire puis laisser sécher soigneusement.		
ENTRETIEN COURANT	TYPE DE DÉTERGENT	PRODUIT	FABRICANT
	Détergent neutre	FILA CLEANER	FILA
		FLOOR CLEANER	FABER CHIMICA
PROCÉDURE *	Nettoyer le sol à l'aide de détergents neutres dilués avec de l'eau selon les instructions du fabricant. Ne pas utiliser de produits contenant des cires ni des additifs brillants. Rincer abondamment à l'eau claire puis laisser sécher soigneusement.		
ÉLIMINATION TACHES COLORÉES (vin, fruits, café, nicotine)	TYPE DE DÉTERGENT	PRODUIT	FABRICANT
	Détergent multifonction	COLORED STAIN REMOVER	FABER CHIMICA
		PS 87	FILA
PROCÉDURE *	Utiliser selon le dosage indiqué par le fabricant directement sur la tache, laisser agir le temps indiqué par le fabricant puis rincer la surface à l'eau claire. Si la tache persiste, répéter l'opération.		
ÉLIMINATION D'AURÉOLES MATES OU BRILLANTES	TYPE DE DÉTERGENT	PRODUIT	FABRICANT
	Détergent multifonction	TILE CLEANER	FABER CHIMICA
		PS 87	FILA
PROCÉDURE *	Utiliser selon le dosage indiqué par le fabricant directement sur la tache, laisser agir le temps indiqué puis éliminer le résidu avec une éponge humide. Si la tache persiste, répéter l'opération.		

En cas de saleté incrustée ne partant pas avec un détergent ordinaire, nous vous conseillons de consulter le tableau ci-dessous:

TYPE DE SALETE	SOLUTION	DETERGENTS	FABRICANT
TACHES NON ORGANIQUES			
carbone, efflorescences calcaires, craie, traces métalliques, rouille, crayon (gris), tempera naturels.	ACIDE	DETERDEK TILE CLEANER	Fila Industria Chimica S.p.A. Faber Chimica
TACHES ORGANIQUES			
traces de caoutchouc (semelles, pneumatiques)	ALCALINE	FILA PS/87 TILE CLEANER	Fila Industria Chimica S.p.A. Faber Chimica
coca cola, café, vin, bière, glace, huile et matières grasses animales et végétales, moutarde, ketchup, mayonnaise, confiture, teinture pour cheveux, shampooing, rouge à lèvres, chewing-gum, encres lampostil	ALCALINE	FILA PS/87 TILE CLEANER	Fila Industria Chimica S.p.A. Faber Chimica
TACHES SYNTHÉTIQUES			
huiles silicone et mécaniques, silicone, résines, émaux, laques, bitume, cire de bougie, vernis, goudron, caoutchouc, traces de scotch	SOLVANT	FILASOLV ACETONE DILUENTE NITRO	Fila Industria Chimica S.p.A. In Commercio In Commercio
CAS PARTICULIERS			
TYPE DE SALETE	DETERGENTS	MARCHE À SUIVRE	
TACHES PARTICULIÈRES			
élimination des cires protectrices	DETERDEK (Fila) TILE CLEANER (Faber)	Pour éliminer les résidus de cire, effectuer un nettoyage acide en frottant avec vigueur à l'aide d'un tampon scotch-brite jusqu'à disparition complète du matériau solide. S'il demeure des auréoles de silicone, répartir du filasolv en laissant agir jusqu'à son évaporation complète. Rincer abondamment avec de l'eau chaude propre.	
auréoles circulaires des ventouses	FILA HOBBY (Fila) PS/87 (Fila)	A l'aide du vaporisateur prévu à cet effet (pour fila hobby), vaporiser le détergent sur le carreau qui présente l'auréole. Laisser agir pendant quelques secondes (ne jamais laisser sécher complètement), puis frotter avec vigueur à l'aide d'un tampon scotch-brite humidifié et rincer abondamment avec de l'eau chaude propre.	
TACHES RÉSISTANTES			
toutes les taches non organiques (voir plus haut) qui n'ont pas été éliminées avec DETERDEK	PH ZERO (Fila Industria Chimica)	Ph zero est un acide plus puissant que deterdek. son action sur les taches de type non organique est donc plus agressive. Utiliser uniquement dans les cas extrêmes et après plusieurs tentatives avec deterdek.	
toutes les taches organiques (voir plus haut) qui n'ont pas été éliminées avec ps/87	DRASTIC (Fila Industria Chimica)	Drastic est un produit alcalin plus puissant que ps/87. son action sur les taches de type organique est donc plus agressive. Utiliser uniquement dans les cas extrêmes et après plusieurs tentatives avec ps/87.	

Fabricants des détergents : FILA (Padova): Tel. +39 049 9467300 - Fax +39 049 9460753 - fila@filachim.it - www.filachim.com - FABER CHIMICA s.r.l. (Ancona): Tel. +39 073 2627178 - Fax +39 073 222935 - www.faberchimica.com

## Reinigung und pflege der produkte von Tuscania

GELÄPTE OBERFLÄCHEN			
REINIGUNG BEI BAUSTELLENENDE ZEMENTSTUCK	ART DES REINIGUNGSMITTELS	PRODUKT	HERSTELLER
	Saurer Reinigungsmittel	TILE CLEANER	FABER CHIMICA
		FILA CLEANER	FILA
		FLOOR CLEANER	FABER CHIMICA
PROZEDUR *	Bei mit Harzen oder Latex stabilisiertem Zementstück muss die Reinigung sofort mit Schwamm und viel Wasser erfolgen. Mit einer im Wasser verdünnten, leicht sauren oder neutralen. Reinigungslösung säubern und nach den vom Hersteller erteilten Vorgaben mit Monobürste oder Reissbürste gründlich scheuern. Mit viel sauberem Wasser nachwischen und die Flüssigkeit komplett mit einer Gummispachtel und Lappen oder mit Nasssauger entfernen. Die Reinigung und das Nachwischen mit sauberem Wasser zweimal wiederholen und dann gut trocknen lassen.		
REINIGUNG BEI BAUSTELLENENDE EPOXY STUCK	ART DES REINIGUNGSMITTELS	PRODUKT	HERSTELLER
	Alkalines Reinigungsmittel	EPOXY REMOVER	FABER CHIMICA
		FILA CR 10	FILA
PROZEDUR *	Bei Epoxy Stuck muss die Reinigung sofort mit Schwamm und viel Wasser erfolgen. Am Tag nach dem Verfugen den Fußboden nach den vom Hersteller erteilten Vorgaben mit einer Lösung auf Basis eines in Wasser verdünnten alkalischen Reinigungsmittels mit Monobürste oder Reissbürste reinigen und gründlich scheuern. Mit viel sauberem Wasser nachwischen und die Flüssigkeit komplett mit einer Gummispachtel und Lappen oder mit Nasssauger entfernen. Die Reinigung und das Nachwischen mit sauberem Wasser zweimal wiederholen und dann gut trocknen lassen. Wenn durchscheinende Rückstände bleiben sollten, muss ein geeignetes Lösungsmittel wie beispielsweise Nitro-Verdünner verwendet werden.		
EMPFOHLENE REINIGUNG VOR DEM EINRICHTEN DER RÄUME	ART DES REINIGUNGSMITTELS	PRODUKT	HERSTELLER
	Leicht saures oder neutrales Reinigungsmittel	TILE CLEANER	FABER CHIMICA
		FILA CLEANER	FILA
		FLOOR CLEANER	FABER CHIMICA
PROZEDUR *	Den Fußboden nach den vom Hersteller erteilten Vorgaben mit einer in Wasser verdünnten, leicht sauren oder neutralen Reinigungslösung mit Monobürste oder Reissbürste reinigen und ordentlich scheuern. Mit viel sauberem Wasser nachwischen und die Flüssigkeit komplett mit einer Gummispachtel und Lappen oder mit Nasssauger entfernen. Die Reinigung und das Nachwischen mit sauberem Wasser zweimal wiederholen und dann gut trocknen lassen.		
PFLEGE	ART DES REINIGUNGSMITTELS	PRODUKT	HERSTELLER
	Neutrales Reinigungsmittel	FILA CLEANER	FILA
		FLOOR CLEANER	FABER CHIMICA
PROZEDUR *	Den Fußboden nach den vom Hersteller erteilten Vorgaben mit in Wasser verdünnten, neutralen Reinigungsmitteln säubern. Keine Produkte mit Wachsen oder polierenden Wirkstoffen verwenden. Mit viel sauberem Wasser nachwischen und dann gründlich trocknen lassen.		
ENTFERNEN VON BUNTEN FLECKEN (Wein, Obst, Kaffee, Nikotin)	ART DES REINIGUNGSMITTELS	PRODUKT	HERSTELLER
	Polyfunktionelles Reinigungsmittel	COLORED STAIN REMOVER	FABER CHIMICA
		PS 87	FILA
PROZEDUR *	In der vom Hersteller angegebenen Konzentration direkt auf den Flecken auftragen, über die vom Hersteller angegebene Zeitdauer einwirken lassen und dann die Fläche nachwischen. Wenn der Flecken nicht verschwindet, den Vorgang wiederholen.		
ENTFERNEN VON FETTEN SUBSTANZEN	ART DES REINIGUNGSMITTELS	PRODUKT	HERSTELLER
	Polyfunktionelles Reinigungsmittel	OIL & GREASE REMOVER	FABER CHIMICA
		PS 87	FILA
PROZEDUR *	In der vom Hersteller angegebenen Konzentration direkt auf den Flecken auftragen, über die vom Hersteller empfohlene Zeitdauer einwirken lassen und dann den Rückstand mit einem feuchten Schwamm entfernen. Wenn der Flecken nicht verschwindet, den Vorgang wiederholen.		

NATÜRLICHE UND STRUKTURIERTE OBERFLÄCHEN			
REINIGUNG BEI BAUSTELLENENDE ZEMENTSTUCK	ART DES REINIGUNGSMITTELS	PRODUKT	HERSTELLER
	Saurer Reinigungsmittel	CEMENT REMOVER	FABER CHIMICA
		KERANET	MAPEI
		DETERDEK	FILA
PROZEDUR *	Bei mit Harzen oder mit Latex stabilisiertem Zementstück muss das Entfernen sofort mit Schwamm und gründlichem Nachwischen erfolgen. Bei hart gewordenem Stück innerhalb von 7 Tagen ein mit Wasser verdünntes saures Nachverlegungs-Reinigungsmittel verwenden und dabei die vom Hersteller mitgeteilte Vorgehensweise, mit Monobürste oder Reissbürste und Scheuern, befolgen. Mit viel sauberem Wasser nachwischen und die Flüssigkeit komplett mit einer Gummispachtel und sauberen Lappen oder Nasssauger entfernen. Die Reinigung und das Nachwischen mit sauberem Wasser zweimal wiederholen und dann gut trocknen lassen.		
REINIGUNG BEI BAUSTELLENENDE EPOXY STUCK	ART DES REINIGUNGSMITTELS	PRODUKT	HERSTELLER
	Alkalines Reinigungsmittel	EPOXY REMOVER	FABER CHIMICA
		FILA CR 10	FILA
PROZEDUR *	Den Fußboden nach den vom Hersteller erteilten Vorgaben mit einer im Wasser verdünnten, leicht sauren oder neutralen Reinigungslösung säubern und mit Monobürste oder Reissbürste gründlich scheuern. Mit viel sauberem Wasser nachwischen und die Flüssigkeit komplett mit einer Gummispachtel und sauberen Lappen oder Nasssauger entfernen. Die Reinigung und das Nachwischen mit sauberem Wasser zweimal wiederholen und dann gut trocknen lassen.		
PFLEGE	ART DES REINIGUNGSMITTELS	PRODUKT	HERSTELLER
	Neutrales Reinigungsmittel	FILA CLEANER	FILA
		FLOOR CLEANER	FABER CHIMICA
PROZEDUR *	Den Fußboden nach den vom Hersteller erteilten Vorgaben mit in Wasser verdünnten, neutralen Reinigungsmitteln säubern. Keine Produkte mit Wachsen oder polierenden Wirkstoffen verwenden. Mit viel sauberem Wasser nachwischen und dann gründlich trocknen lassen.		
ENTFERNEN VON BUNTEN FLECKEN (Wein, Obst, Kaffee, Nikotin)	ART DES REINIGUNGSMITTELS	PRODUKT	HERSTELLER
	Polyfunktionelles Reinigungsmittel	COLORED STAIN REMOVER	FABER CHIMICA
		PS 87	FILA
PROZEDUR *	In der vom Hersteller angegebenen Konzentration direkt auf den Flecken auftragen, über die vom Hersteller angegebene Zeitdauer einwirken lassen und dann die Fläche mit sauberem Wasser nachwischen. Wenn der Flecken nicht verschwindet, den Vorgang wiederholen.		
ENTFERNEN VON FETTEN SUBSTANZEN	ART DES REINIGUNGSMITTELS	PRODUKT	HERSTELLER
	Polyfunktionelles Reinigungsmittel	TILE CLEANER	FABER CHIMICA
		PS 87	FILA
PROZEDUR *	In der vom Hersteller angegebenen Konzentration direkt auf den Flecken auftragen, über die vom Hersteller angegebene Zeitdauer einwirken lassen und dann die Rückstände mit einem feuchten Schwamm entfernen. Wenn der Flecken nicht verschwindet, den Vorgang wiederholen.		

Bei Schmutzrückständen, die sich durch gewöhnliche Reinigungsmittel nicht entfernen lassen, möchten wir auf die folgende Tabelle hinweisen:

ART DER VERSCHMUTZUNG	LÖSUNG	REINIGUNGSMITTEL	HERSTELLER
<b>ANORGANISCHE FLECKEN</b>			
kohle, kalkausblühungen, gips, metallsuren, rost, bleistift (graphit), natürliche temperafarben.	SAUER	DETERDEK TILE CLEANER	Fila Industria Chimica S.p.A. Faber Chimica
<b>ORGANISCHE FLECKEN</b>			
gummispuren (schuhsohlen, reifen)	ALKALISCH	FILA PS/87 TILE CLEANER	Fila Industria Chimica S.p.A. Faber Chimica
coca cola, kaffee, wein, bier, eis, tierische und pflanzliche öle und fette, senf, ketchup, mayonnaise, marmelade, haarfärbemittel, shampoo, lippenstift, kaugummi, tinte, filzstift	ALKALISCH	FILA PS/87 TILE CLEANER	Fila Industria Chimica S.p.A. Faber Chimica
<b>SYNTHETISCHE FLECKEN</b>			
silikon- und mechanische öle, silikon, harze, glasuren, lacke, bitumen, kerzenwachs, anstrichfarben, teer, kautschuk, klebebandreste	LÖSUNGS-MITTEL	FILASOLV ACETONE DILUENTE NITRO	Fila Industria Chimica S.p.A. In Commercio In Commercio
<b>SONDERFÄLLE</b>			
ART DER VERSCHMUTZUNG	REINIGUNGSMITTEL	VORGANGSWEISE	
<b>BESONDERE FLECKEN</b>			
entfernung von schutzwachs	DETERDEK (Fila) TILE CLEANER (Faber)	Zur entfernung der wachsereste die reinigung mit der sauren lösung vornehmen; energisch mit einem scotch-brite-bausch reiben, bis das feste material vollkommen entfernt wurde. Sollten silikon-schlieren verbleiben, filasolv auftragen und einwirken lassen, bis es vollkommen verdampft ist. Mit reichlich warmem, sauberem wasser abspülen.	
runde schlieren von saugnäpfen	FILA HOBBY (Fila) PS/87 (Fila)	Das reinigungsmittel mit der sprühhilfe (für fila hobby) auf die filiese sprühen, auf der die schlieren zu sehen sind. Ein paar sekunden lang einwirken lassen (doch nie so lange, bis die oberfläche vollkommen trocken ist), mit einem befeuchteten scotchbrite-bausch energisch reiben und mit reichlich warmem, sauberem wasser abspülen.	
<b>HARTNÄCKIGE FLECKEN</b>			
sämtliche anorganischen flecken (siehe oben), die nicht mit DETERDEK entfernt werden können	PH ZERO (Fila Industria Chimica)	Ph zero ist eine säure, die stärker ist als deterdek, daher ist ihre wirkung aggressiver gegenüber anorganischen flecken. Nur in fällen verwenden, die als extrem eingestuft werden und nachdem die reinigung vorher auch mehrmals mit deterdek probiert wurde.	
sämtliche organischen flecken (siehe oben), die nicht mit PS/87 entfernt werden können	DRASTIC (Fila Industria Chimica)	Drastic ist ein alkalisches produkt, das stärker ist als ps/87, daher ist seine wirkung aggressiver gegenüber organischen flecken. Nur in fällen verwenden, die als extrem eingestuft werden und nachdem die reinigung vorher auch mehrmals mit ps/87 probiert wurde.	

Hersteller von Reinigungsmitteln: FILA (Padova): Tel. +39 049 9467300 - Fax +39 049 9460753 - fila@filachim.it - www.filachim.com - FABER CHIMICA s.r.l. (Ancona): Tel. +39 073 2627178 - Fax +39 073 222935 - www.faberchimica.com



# Listello coprispigolo - Edge-protection batten - Baguette d'angle - Randabdeckleiste

Il **listello coprispigolo** rappresenta un'idea veramente geniale quale elemento di finitura per ogni pavimento e rivestimento ceramico. Versatile e semplicissimo da posare, questo particolare raccordo, ricavato direttamente dalla piastrella, viene fornito su misura per qualsiasi formato. La sua applicazione serve a chiusura per ogni angolo interno/esterno, per rifinire gradini, battiscopa, coprimuretti, per chiudere le estremità dei pavimenti e dei rivestimenti. Particolare importante: a garanzia di un lavoro ben rifinito e complessivamente armonioso, viene **fornito della stessa lunghezza e spessore della piastrella richiesta**. Lo spessore potrà variare dai 6 mm ai 20 mm.

The **edge-protection batten** is a truly remarkable idea for finishing any flooring and wall covering in ceramic. Versatile and extremely easy to fit, this small joining piece, made entirely from tiles, is supplied to measure for any format. It serves to create an edging for any indoor/outdoor corner, to finish steps, as skirting, as tiles on the top of low walls, and to close the edges around floors and wall coverings. Particularly important: to guarantee a well-finished job with an overall harmonious result, **it is supplied in the same length and thickness as the actual tiles used**. The thickness may vary between 6 mm and 20 mm.

La **baguette d'angle** traduit l'idée vraiment géniale d'un élément de finition pour tout sol et revêtement céramique. Polyvalent et ultra-simple à poser, ce raccord particulier, dérivé directement du carreau, est fourni sur mesure pour tout type de format. Son application sert de fermeture pour tout angle interne/externe, pour peaufiner les marches, la plinthe, les couvre-murs, pour fermer les extrémités des sols et des revêtements. Détail important: pour garantir un travail bien fini et globalement harmonieux, elle est **fournie dans la même longueur et épaisseur que le carreau demandé**. L'épaisseur pourra varier de 6 mm au 20 mm.

Die **Randabdeckleiste** ist eine wirklich brillante Idee als Abschlusselement für alle keramischen Boden- und Wandfliesen. Dieses spezielle Verbindungsstück ist vielseitig und einfach zu installieren und wird direkt aus der Fliese gefertigt und für jede Größe geliefert. Es kann zum Abschluss für jede Innen-/Außenecke und für Stufen, Sockelleisten, Wandverkleidungen, zum Schließen der Böden und der Wandverkleidungen verwendet werden. Wichtiges Detail: Um ein gut verarbeitetes und harmonisches Gesamtbild zu gewährleisten, **wird das Verbindungsstück in der gleichen Länge und Stärke der gewünschten Fliese geliefert**. Die Stärke kann von 6 mm bis 20 mm variieren.



## Applicazioni in opera - Applications - Applications sur le chantier - Anwendungen auf der Baustelle

<p><b>gradini in opera</b> fitting on steps marches sur le chantier Trittschufen auf der Baustelle</p>	<p><b>coprispigolo quarter round esterno</b> round outer tile for covering edges, quarter baguette d'angle quart de rond externe Viertelstababdeckung im Außenbereich</p>	<p><b>chiusura pavimento</b> as edging for floor layouts fermeture sol Abschluss für Bodenfliesen</p>
<p><b>coprimuro in opera</b> as tiles on low wall couvre-mur sur le chantier Wandabdeckung auf der Baustelle</p>	<p><b>coprispigolo interno</b> as an internal edge-protection batten baguette d'angle interne Randabdeckung auf der Baustelle</p>	<p><b>elemento ad elle in opera</b> L-shaped element being fitted élément en L sur le chantier L-Element auf der Baustelle</p>
<p><b>raccordo pavimento - rivestimento</b> to joint floor and wall tiles raccord sol - revêtement Verbindung Bodenbelag - Wandverkleidung</p>	<p><b>cove base in opera</b> base cove being fitted plinthe sur le chantier Abdeckung auf der Baustelle</p>	<p><b>chiusura rivestimento</b> as edging for wall layouts fermeture revêtement Abschluss für Wandfliesen</p>

## Certificazioni - Certifications - Certifications - Zertifizierungen

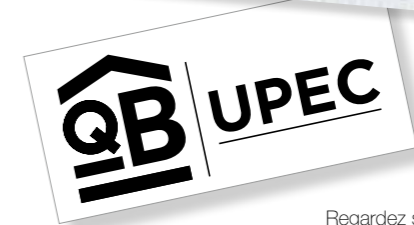

Regardez sur le site internet [www.cstb.fr](http://www.cstb.fr) s'il vous plaît

## Legenda - Legend - Légend - Zeichenerklärung

**rivestimenti**  
wall tiles - faiences - Wandfliesen

**pavimenti**  
floor tiles - carrelage sol - Bodenfliesen

**spessore**  
tickness - épaisseur - stärke

**resistenza allo scivolamento DIN 51130 - sliding resistance DIN 51130 - résistance au glissement DIN 51130 - gleitwiderstands DIN 51130**

**R9 R10 R11 R12 R13**

**stampa digitale**  
digital print - haute definition - Digitaltechnik

**HD**

## aspetto della superficie / stonalizzazione surface appearance - oberflächenaussehen - aspect de la surface

<p><b>V1</b> <b>LOW</b></p> <p><b>V1/LOW</b> Aspetto uniforme Uniform appearance Aspect uniforme Einheitliches Aussehen</p>	<p><b>V2</b> <b>MODERATE</b></p> <p><b>V2/MODERATE</b> Lieve variazione Slight variations Légère variation Leichte Abweichung</p>
<p><b>V3</b> <b>HIGH</b></p> <p><b>V3/HIGH</b> Moderata variazione Moderate variations Variation modérée Mäßige Abweichung</p>	<p><b>V4</b> <b>RANDOM</b></p> <p><b>V4/RANDOM</b> Forte stonalizzazione Substantial variations Effet dénuancé très accentué Starkes Farbspiel</p>

- La diversità di grafica e la naturale stonalizzazione delle piastrelle costituiscono la caratteristica propria di questa serie. Si consiglia di miscelare le varie scatole durante la posa e di scegliere le piastrelle da diversi colli per evitare il ripetersi della stessa grafica accostata.
- The different graphics and the natural shading of each tile are intentional characteristics of this range. When laying tiles, we recommend mixing the various boxes and choosing tiles from different boxes, in order to avoid placing tiles with identical graphics adjacent to each other.
- La diversité graphique et la variété de tonalités naturelle des carreaux caractérisent cette série. Il est recommandé de mélanger les carreaux de différentes boîtes au cours de la pose et de les choisir dans différents colis pour éviter que les mêmes dessins ne se trouvent côte à côte.
- Die unterschiedlichen Maserungen und der natürlichen Farbspiel sind gewollten Eigenschaften dieser Serie. Bei der Verlegung es wird empfohlen Fliesen aus verschiedenen Kartons zu mischen.

## Condizioni generali di vendita

- La firma della conferma d’ordine, l'accettazione di una fattura o di una fornitura equivalgono all’approvazione delle presenti condizioni, le quali - in caso di rapporti commerciali correnti - sono valide anche per i singoli contratti senza indicazione particolare. La variazione o la nullità di singole condizioni non compromette la validità delle altre condizioni.
- Le dichiarazioni fatte da rappresentanti o da altri che divergessero dalle presenti condizioni, che riconoscessero difetti o che contenessero determinate garanzie, sono comunque vincolate alla nostra scrittura.
- Le nostre offerte sono senza impegno e si intendono con partenza dal luogo di fornitura o dal nostro deposito. Siamo autorizzati ad affidare a terzi l'esecuzione di contratti e la fatturazione; in tal caso l'acquirente accetta la validità delle nostre condizioni generali di vendita che si instaurano fra lui stesso e il nostro intermediario. Le forniture si effettuano in base alla disponibilità. Ci facciamo comunque premura di rispettare i termini di consegna ma senza garanzia alcuna.
- Ogni fornitura – parziale, successiva o allegata – costituisce un atto commerciale giuridicamente autonomo e non coinvolge le restanti consegne. Una fornitura ritardata non giustifica alcun risarcimento dei danni o annullamento del contratto.
- Difficoltà di produzione, conflitti di lavoro, catastrofi, impedimenti di trasporto, agitazioni sociali, difficoltà di reperimento di materiale grezzo, accentuato incremento dei prezzi e casi di forza maggiore ci esonerano nel contempo dall’obbligo della fornitura.
- Per ordini di materiale rettificato con posa mista e/o modulare è necessario comunicarlo al momento dell’ordine; così come per ordini di completamento. Tuscania S.p.A. non risponde di contestazioni di calibro se non espressamente comunicato.
- La merce ordinata – soprattutto in caso di forniture parziali dilazionate – va ritirata dall'acquirente al massimo entro un mese. La merce non prelevata – decorso il termine di presa di consegna – da parte nostra può essere utilizzata in altro modo o messa in conto senza variazioni nella scadenza di pagamento. Gli sconti a saldo verranno conteggiati o dedotti ad accettazione o pagamento avvenuti.
- La spedizione avviene per conto ed a rischio e pericolo dell’acquirente. I rischi e pericoli passano a carico dell’acquirente dal momento in cui viene segnalata la disponibilità della merce pronta per la spedizione o per il prelievo, altrimenti dal momento del prelievo stesso. In caso di merce difettosa si suppone che il difetto sia sorto dopo il passaggio della merce all’acquirente, questi semmai deve dimostrare il contrario. Danni all’imballaggio o difetti alle palette vanno denunciati al più tardi durante il carico della merce. Per quanto concerne l'utilizzo dei nostri prodotti garantiamo soltanto in conformità alle indicazioni scritte.
- La garanzia viene meno per merci di seconda o terza scelta, assortimenti minori o partite speciali, soprattutto in riferimento alla protezione dal gelo. La denuncia di eventuali difetti va effettuata al momento della presa in consegna della merce o comunque prima della sua ulteriore consegna o lavorazione, e al più tardi entro 8 giorni dalla presa in consegna va segnalata per iscritto alla nostra gestione commerciale. Siamo autorizzati ad esaminare la denuncia entro 15 giorni dalla data di arrivo. Qualora la denuncia risultasse infondata l’acquirente si assume le spese del controllo effettuato. Se invece essa risulta motivata, si procede – a nostra scelta – alla sostituzione della merce entro un adeguato lasso di tempo o ad una riduzione del prezzo d’acquisto. È esclusa ogni qualsiasi ulteriore rivendicazione. La spedizione di ritorno della merce viene accettata solo previo accordo scritto e va effettuata franco di porto, a spese e a rischio dell’acquirente, fermo restando lo stato originale della nostra merce.
- Sono esclusi i reclami per merce già posata qualora la posa non sia stata eseguita da un tecnico autorizzato dalla nostra azienda.
- I reclami per difetti nascosti vanno effettuati al più tardi entro 6 mesi dalla presa in consegna della merce.
- In caso di forniture supplementari non si garantisce per l’identità del colore rispetto alla merce già ricevuta. Non si garantisce che non vengano lesi diritti protettivi di terzi.
- Per il conteggio vale il prezzo corrente nel giorno della nostra disponibilità alla fornitura o consegna. Le consegne franco di porto e di dogana non ci obbligano alla presentazione di denaro. Le palette vengono fatturate fintanto che al momento della fornitura non riceviamo palette di ricambio. Le nostre fatture vanno saldate entro 30 giorni dalla data di emissione.
- La detrazione di sconti non è ammissibile fintanto che permangono fatture inevase. L’insolviibilità del cliente comporta un’immediata decorrenza del suo debito. La presa a riposo di cambi necessita di una convenzione particolare e funge solo da dilazione. Dalla scadenza il cliente ci offre la cessione dei suoi crediti nell’equivalente del suo debito per l'accettazione in qualsiasi momento.
- Sono validi quei pagamenti che vengono effettuati unicamente presso gli istituti bancari da noi segnalati per iscritto. I versamenti vanno conteggiati dapprima in base ai costi e agli interessi e quindi al valore fatturato.
- La vendita viene fatta con riserva di proprietà di cui agli articoli 1523 c.c. e seguenti sicché le cose vendute passeranno in proprietà all’acquirente soltanto col pagamento dell’ultima rata. L’acquirente assume tutti i rischi e pericoli anche per i casi fortuiti o di forza maggiore obbligandosi a denunciare immediatamente alla venditrice le eventuali azioni conservative o esecutive promesse da terzi nonché ogni rimozione o trasloco della merce in altre località.
- Il mancato o ritardato pagamento di una sola rata provoca la risoluzione di diritto del contratto e fa decadere il debitore dal beneficio del termine. In questo caso il committente riconosce a Tuscania S.p.A. il diritto di ottenere la riconsegna della merce venduta facendo ricorso alla procedura di cui all’art. 833 c.p.c. Le rate già pagate resteranno a totale beneficio della venditrice a rifusione delle spese incontrate nella vendita e dei danni subiti salvo il diritto di ripetere i danni maggiori.
- La concordata riserva sulla proprietà comprende anche le palette e gli imballaggi. Dobbiamo essere informati sugli eventuali pignoramenti della nostra merce.
- Per qualsiasi controversia o contestazione è eletto esclusivamente competente il foro di Modena.

## General conditions of sale

- Your signature on the order confirmation or the acceptance of an invoice or a supply is indicates your approval of these conditions, which - in the case of an ongoing commercial relationship - are also valid for single contracts without any particular indication. If single conditions are changed or found to be void, this will not affect the validity of the other conditions.
- In any case, statements made by representatives or others that contradict these conditions, recognise defects or that contain certain guarantees are not valid without our written confirmation.
- Our offers are not binding and are understood to be from the place of supply or our warehouse. We are authorised to entrust the execution of contracts and billing to third parties; in that case, the purchaser accepts the validity of our general conditions of sale, which are valid between the purchaser and our intermediary. Supplies are made based on availability. In any case, we undertake to respect the terms of delivery but without any guarantee.
- Each supply - partial, subsequent or annexed - is a legally-independent commercial transaction and does not involve the remaining deliveries. A late supply does not justify compensation for damages or the cancellation of the contract.
- Production difficulties, labour disputes, catastrophes, transport problems, social unrest, difficulties in obtaining raw materials, price increases and cases of force majeure will simultaneously release us from the obligation to make the supply.
- It is necessary to communicate in the time of the order if you need material rectified for modular laying or if it is a completion of an old order. Without receiving this previous communication, Tuscania SPA will not accept any claims for caliber problems.
- The purchaser must pick up the goods ordered within a maximum of one month - especially in the case of partially delayed supplies. After the delivery term has passed, we can use any goods that have not been picked up in another way or invoice them without any changes to payment due dates. Payment discounts will be applied or deducted upon acceptance or payment.
- Shipment is on the purchaser’s behalf and its risk. Risks and dangers pass to the purchaser at the time it is notified that the goods are ready for shipment or pick-up or, otherwise, at the moment of the pick-up itself. In the case of defective goods, it is assumed that the defect arose after the transfer of the goods to the purchaser unless it can be proven otherwise. Damage to packing materials or defective pallets must be reported no later than the loading of the goods. As for the use of our products, we only guarantee conformity to their written descriptions.
- The warranty does not apply to goods of second or third quality, small assortments or special lots, especially in reference to frost protection. Any other defects must be reported at the time of the delivery of the goods or, in any case, before another delivery or work and, at the latest, within 8 days from delivery, in writing to our sales department. We are authorised to examine the claim within 15 days of its date of arrival. If the claim is determined to be unfounded, the purchaser will be responsible for the expense of the examination made. If, however, the claim is justified, we will - at our option - replace the goods within an adequate period of time or at a reduced purchase price. Any other claim is excluded. Shipments of returned goods are only accepted with our prior written agreement and must be made prepaid, at the purchaser’s risk and expense, so long as our goods are in their original condition.
- No claims will be accepted for goods already laid unless performed by a technician authorised by our company.
- Claims for hidden defects must be made no later than 6 months from the delivery of the goods.
- In the case of additional supplies, we cannot guarantee that the colour will be identical to that of the goods already received. We cannot guarantee that the protective rights of third parties have not been damaged.
- Goods will be billed at their current price as of the date of our availability to make the supply or delivery. Prepaid and duty-free deliveries do not obligate us to payout cash. Pallets will be billed if, at the moment of the supply, we do not receive pallets in exchange. Our invoices are payable within 30 days from the date of issue.
- Discounts may not be taken so long as there are unpaid invoices. The customer’s insolvency makes its debt immediately payable. The acceptance of bills of exchange requires a special agreement and serves only to extend the terms. Upon their expiration, the customer offers to transfer credits to us equivalent to its debt for acceptance at any time.
- The only valid payments are those made to the banking institutions specified by us in writing. Payments will be applied first to costs and interests and then to the value invoiced.
- Sales are made with the reservation of ownership referred to in articles 1523 and following of the Italian Civil Code since ownership of the goods sold only passes to the purchaser when the last instalment is paid. The purchaser assumes all risks and dangers, even for accidents and force majeure, undertaking to immediately inform the vendor of any attachments or liens by third parties as well as any removal of the goods to another location.
- The late or missing payment of even a single instalment will lead to the cancellation of the contract by law and the debtor will lose the benefit of extended payment terms. In this case, the customer recognises the right of Tuscania S.p.A. to take back the goods sold through recourse to the procedure referred to in article 833 of the Italian Code of Civil Procedure. The vendor will keep all instalments paid to cover the expenses of the sale and the damages suffered except for the right to compensation for greater damages.
- The agreed-upon reservation of ownership also includes the pallets and packing materials. We must be informed of any seizures of our goods.
- The Court of Modena will be exclusively competent for any disagreement or dispute.



## Conditions générales de vente

- La signature d'une commande, l'acceptation d'une facture ou de la fourniture équivaut à approuver les présentes conditions générales de vente qui en cas de rapports commerciaux courants sont applicables également aux simples contrats ne contenant pas d'indication particulière. La variation ou la nullité des conditions simples n'entrave pas la validité des autres conditions.
- Les déclarations faites par des représentants ou d'autres personnes qui peuvent être différentes des présentes conditions et qui reconnaîtraient des défauts ou contiendraient certaines garanties sont dans tous les cas soumises à notre confirmation écrite.
- Nos offres sont sans engagement et leurs termes s’entendent, départ du lieu de la fourniture ou de notre dépôt. Nous sommes autorisés à confier à des tiers l'exécution de contrats et la facturation; dans ce cas, l'acquéreur accepte la validité de nos conditions générales de vente qui s'établiront entre lui et notre intermédiaire. Les fournitures sont livrées en fonction de la disponibilité. Nous nous efforçons de respecter le plus rapidement possible les termes prévus pour la livraison, mais sans aucune garantie.
- Chaque fourniture partielle, ultérieure ou ajoutée constitue un acte commercial juridiquement autonome et n’implique pas le reste des livraisons. Le retard de livraison d'une fourniture ne justifie pas de requérir une indemnisation pour dommages ou l'annulation du contrat.
- Les difficultés dues à la production, conflits dans le travail, catastrophes, empêchements dus au transport, agitations sociales, difficulté rencontrée dans la recherche de la matière première, hausse importante des prix et les cas de force majeure nous exonèrent de toute obligation de fourniture.
- Pour commandes de materiel en finition rectifié pose modulaire et/ou multiformat c'est impératif de le communiquer au moment de la commande. Tuscania spa décline toute responsabilité pour éventuelles réclamations de calibre concernant complements de commande ou le calibre n'a pas été expressément indiquée au moment de la commande.
- La marchandise commandée, surtout en cas de fourniture partielle retardée, sera enlevée par l'acquéreur dans un délai maximal de un mois. La marchandise non retirée dans le délai imparti par les termes de livraison, pourra être utilisée d'une autre manière par nos services ou facturée sans que la date d'échéance de paiement ne soit modifiée. Le solde des remises seront comptabilisées ou déduites dès acceptation du paiement ou après le paiement.
- L'expédition s'effectue aux frais et aux risques et périls de l'acquéreur. Les risques et périls sont à la charge de l'acquéreur au moment où on lui indique que la marchandise est disponible ou prête à être expédiée ou enlevée, dans tous les cas au moment de l'enlèvement. En cas de marchandise défectueuse on considère que le défaut a été relevé après le passage de la marchandise à l'acquéreur, dans le cas contraire, ce dernier doit démontrer le contraire. Les dommages ou les défauts sur l'emballage ou les palettes doivent être signalés au plus tard durant le chargement de la marchandise. En ce qui concerne l'utilisation de nos produits, nous garantissons uniquement la conformité avec ce qui est écrit.
- La garantie ne s'applique pas aux marchandises de second ou de troisième choix, aux assortiments mineurs ou à des parties spéciales, surtout en référence à la protection contre le gel. La dénonciation des éventuels défauts doit être effectuée au moment de la livraison de la marchandise ou dans tous les cas avant toute livraison ultérieure ou travaux et il est impératif de signaler au plus tard 8 jours à partir de la livraison tout défaut par écrit, à notre service de gestion commerciale. Nous disposons d'un délai de 15 jours à compter de sa date de réception pour examiner la réclamation. Si la réclamation s'avérait être non fondée, l'acquéreur assumerait les dépenses relatives au contrôle effectué. Si au contraire la réclamation est justifiée, le remplacement de la marchandise est effectué par nos soins dans un laps de temps adapté ou nous procédons à une réduction du prix d'achat. Toute autre réclamation ultérieure est exclue. L'expédition de retour de la marchandise est acceptée uniquement après autorisation écrite de notre part et s'effectue franco de port aux frais et risques de l'acquéreur sous réserve de l'état d'origine de notre marchandise.
- Les réclamations effectuées sur les marchandises déjà posées sont exclues, si la pose n'a pas été effectuée par un technicien autorisé par notre entreprise.
- Les réclamations concernant les défauts cachés doivent être effectuées au plus tard dans un délai de 6 mois après la livraison de la marchandise.
- En cas de fourniture supplémentaire, on ne garantit pas que la couleur est identique à la marchandise déjà reçue. Nous ne garantissons pas que des droits de protection des tiers ne soient pas lésés.
- Pour la facturation, on applique le prix courant en vigueur le jour de la disponibilité de la fourniture ou de la livraison. Les livraisons franco de port et de douane ne nous obligent pas à présenter des sommes d'argent. Les palettes sont facturées jusqu'au moment où nous recevons des palettes de rechange pour la fourniture. Nos factures sont payables 30 jours à partir de leur date d'émission.
- La déduction des remises n'est pas garantie tant que les factures ne sont pas réglées. L'insolvabilité du client comporte un effet immédiat sur sa dette. La prise d'une garantie permettant de se protéger des changements nécessite une convention particulière et octroie uniquement un délai. À partir de la date d'échéance, le client doit être solvable pour la somme due et accepter d'être débité à n'importe quel moment.
- Les paiements valables sont ceux effectués auprès des instituts bancaires que nous avons inscrits par écrit. Les versements sont comptabilisés en premier lieu en fonction des coûts et des intérêts et donc de la valeur facturée.
- La vente est effectuée conformément à la réserve de propriété visée aux articles 1533 et suivants du code civil, ce qui implique que les marchandises appartiendront à l'acquéreur uniquement après le paiement de la dernière traite. L 'acquéreur assume tous les risques et périls même pour les cas fortuits ou de force majeure et s'oblige à dénoncer immédiatement au vendeur les éventuelles actions de conservation ou d'exécution promues par des tiers ainsi que les cas de retrait ou de transport de la marchandise vers d'autres endroits.
- Le non paiement ou le retard de paiement d'une seule traite provoque l'annulation du droit conféré par le contrat et destitue le bénéficiaire du terme de paiement accordé. Dans ce cas, l'acquéreur reconnaît à Tuscania S.p.A. le droit d'obtenir la re-livraison de la marchandise vendue en faisant appel à la procédure visée à l'article 833 du code de procédure civil. Les traites déjà payées resteront au bénéfice du vendeur pour le remboursement des frais encourus durant la vente et des dommages subis à l'exclusion du droit de faire valoir en plus les dommages majeurs.
- La réserve de propriété accordée inclut également les palettes et les emballages. Nous devons également être informés de l'éventuelle saisie de notre marchandise.
- Pour toute controverse ou réclamation seul le Tribunal de Modène est compétent.

## Allgemeine Verkaufsbedingungen

- Dite Unterzeichnung der Auftragsbestätigung, die Annahme einer Rechnung oder einer Lieferung entsprechen der Annahme dieser Bedingungen, die – im Fall von fortlaufenden Geschäftsbeziehungen – auch für einzelne Verträge ohne besondere Hinweise Gültigkeit besitzen. Die Abänderung oder Nichtigkeit einzelner Bedingungen beeinträchtigt nicht die Gültigkeit der restlichen Bedingungen.
- Die von Vertretern oder anderen abgegebenen Erklärungen, die von den vorliegenden Bedingungen abweichen, die Mängel anerkennen oder bestimmte Gewährleistungen beinhalten, müssen von unserer Firma schriftlich bestätigt werden.
- Unsere Angebote sind nicht bindend und verstehen sich mit Versand ab Lieferort oder ab unserem Lager. Wir sind dazu ermächtigt, Dritte mit der Ausführung der Verträge sowie der Rechnungserstellung zu beauftragen; In diesem Fall akzeptiert der Käufer die Gültigkeit unserer allgemeinen Verkaufsbedingungen, die zwischen ihm und unserem Vermittler vereinbart werden. Die Lieferungen erfolgen je nach Verfügbarkeit. Es ist unsere Sorge, die Lieferfristen einzuhalten, doch ohne jegliche Garantie.
- Jede – partielle, nachfolgende oder anliegende – Lieferung stellt einen rechtlich unabhängigen kaufmännischen Handel dar und bezieht nicht die restlichen Lieferungen mit ein. Eine verspätete Lieferung rechtfertigt keinen Schadenersatz oder Vertragskündigung.
- Produktionsschwierigkeiten, Betriebskonflikte, Katastrophen, Transportbehinderungen, soziale Unruhen, Schwierigkeit bei der Beschaffung von Rohstoffen, verstärkte Preiserhöhungen und Situationen höherer Gewalt befreien uns gleichzeitig von der Lieferverpflichtung.
- Bezüglich Rektifiziertes Material, est ist notwendig mitteilen ob mann eine gemischte und/oder modulierte verlegung benötigt, so wie für nachträgige Bestellungen. Die Firma Tuscania Spa ist nicht verandwortlich für kaliber Beanständigungen, wenn es nicht ausdrücklich mitgeteilt wird.
- Die bestellte Ware – insbesondere im Fall von partiellen, verschobenen Lieferungen – muss von dem Käufer innerhalb eines Monats abgeholt werden. Nicht abgeholte Ware kann – nach Ablauf der Lieferzeit – von uns auf unterschiedliche Weise verwendet oder ohne Abänderung der Zahlungsfrist in Rechnung gestellt werden. Die Skonti bei Rechnungsbegleichung werden bei Annahme oder erfolgter Bezahlung angerechnet oder abgezogen.
- Der Versand erfolgt zu Lasten und auf Gefahr des Käufers. Die Risiken und Gefahren gehen auf den Käufer über, sobald er die Meldung der Versandbereitschaft erhalten hat oder die Ware abgeholt wurde. Im Fall von mangelhafter Ware wird davon ausgegangen, dass der Defekt nach der Übergabe an den Käufer verursacht wurde, andernfalls muss der Käufer selbst das Gegenteil beweisen. Schäden an der Verpackung oder Mängel an den Paletten müssen während der Verladung der Ware angezeigt werden. Die Verwendung unserer Produkte garantieren wir ausschließlich in Übereinstimmung mit den schriftlichen Anweisungen.
- Die Garantie verfällt bei Ware zweiter oder dritter Wahl, geringen Sortimenten oder Sonderpartien, insbesondere hinsichtlich des Frostschutzes. Die Meldung eventueller Mängel muss bei Warenannahme oder vor der Weitergabe oder Verarbeitung derselben und spätestens innerhalb von 8 Tagen nach Warenannahme schriftlich bei unserer Geschäftsverwaltung eingereicht werden. Wir sind berechtigt, die Meldung innerhalb von 15 Tagen nach Empfang zu prüfen. Sollte die Meldung als unbegründet angesehen werden, werden dem Käufer die Kosten für die Prüfung angerechnet. Ist diese hingegen begründet, wird die Ware – nach unserem Ermessen – innerhalb einer angemessenen Frist ausgetauscht oder der Kaufpreis vermindert. Ausgeschlossen wird jedwede weitere Forderung. Die Rückerstattung der Ware wird nur nach schriftlichem Einvernehmen angenommen und hat portofrei, auf Kosten und Gefahren des Käufers zu erfolgen, wobei die Ware in unbeschadetem Originalzustand eingeschickt werden muss.
- Ausgeschlossen sind Beanstandungen für schon verlegte Ware, die nicht von einem autorisierten Fachmann unserer Firma verlegt wurde.
- Beanstandungen für nicht sichtbare Mängel müssen innerhalb von 6 Monaten nach Warenannahme eingereicht werden.
- Bei zusätzlichen Lieferungen ist die Farbidentität zu der mit vorherigen Lieferungen erhaltenen Ware nicht gewährleistet. Es wird nicht gewährleistet, dass die Schutzrechte Dritter nicht verletzt werden.
- Für die Rechnung gilt der am Tag der Lieferbereitschaft angesetzte Preis. Die portofreien und zollfreien Lieferungen verpflichten nicht zur Geldvorlage. Die Paletten werden in Rechnung gestellt, sofern keine Ersatzpaletten bei Lieferung zur Verfügung gestellt werden. Unsere Rechnungen müssen innerhalb von 30 Tagen nach Rechnungserstellung beglichen werden.
- Der Abzug vorgesehener Skonti ist nicht zulässig, sofern noch unbezahlte Rechnungen offen sind. Die Zahlungsunfähigkeit des Kunden hat einen unverzüglichen Fristverfall seiner Schulden zur Folge. Die Ruhelegung aufgrund von Warenaustausch erfordert eine besondere Vereinbarung und ist nur als Aufschub anzusehen. Nach Ablauf der Frist stellt uns der Kunde ein seinen Schulden entsprechendes Guthaben als Garantie zur Verfügung.
- Gültig sind ausschließlich die Zahlungen, die bei den von uns schriftlich angezeigten Bankinstituten geleistet werden. Die Überweisungen werden von vornherein anhand der Kosten und Zinsen und des Rechnungswertes berechnet.
- Der Verkauf erfolgt mit Eigentumsvorbehalt gemäß der Artikel 1523 des Zivilgesetzbuches und Ergänzungen, so dass die verkaufte Ware erst mit der Zahlung der letzten Rate in den Besitz des Käufers übergeht. Der Käufer übernimmt, auch in Zufallsfällen oder bei Fällen höherer Gewalt, alle Risiken und Gefahren und verpflichtet sich, dem Verkäufer unverzüglich eventuelle Vollstreckungs – oder Sicherstellungsforderungen, die von Dritten gestellt werden, sowie jedwede Beseitigung oder Verlegung der Ware in andere Orte anzuzeigen.
- Eine fehlende oder verspätete Zahlung einer einzigen Rate hat die rechtliche Vertragsauflösung zur Folge und der Schuldner verliert das Recht auf Ratenzahlung. In diesem Fall erkennt der Auftraggeber der Tuscania S.p.A. das Recht auf Rückerstattung der verkauften Ware an, indem er das von Artikel 833 der Zivilgesetzordnung vorgesehene Schlichtungsverfahren anstrebt. Die zuvor bezahlten Raten bleiben als Entschädigung für die Verkaufskosten und Schäden in Besitz des Verkäufers, sofern keine schwerwiegenderen Schäden entstanden sind.
- Der vereinbarte Vorbehalt hinsichtlich des Eigentumsrechtes schließt zudem die Paletten und Verpackungen mit ein. Wir müssen über eventuelle Pfändungen unserer Ware unverzüglich informiert werden.
- Für jede Streitigkeit oder Beanstandung ist ausschließlich das Gericht von Modena zuständig.

# Tabella pesi ed imballi - Sizes weight and packaging Mesures poids et emballages - Tabelle der Gewichte und Verpackungen

formati - sizes - tailles - formate			pz. x box	mq. x box	kg. x box	box x pal.	mq. x pal.	kg. x pal.	
122,6x122,6 cm 48"x48" (rettificato)	<b>NEW</b>								
90x90 cm 36"x36" (rettificato)	<b>NEW</b>								
90x90 cm 36"x36" FP2 (rettificato)	<b>NEW</b>								
90x90 cm 36"x36" FP2 (naturale)	<b>NEW</b>								
80x160 cm 31"x62" (rettificato) (lappato e rettificato)	<b>NEW</b>								
75x75 cm 30"x30" (rettificato)		10 mm	2	1,13	23,50	45	50,85	1070	80x120x90
61,5x61,5 cm 24"x24" (naturale)		10 mm	4	1,51	34,00	30	45,30	1030	80x120x75
61,5x61,5 cm 24"x24" FP2 (naturale)		20 mm	2	0,76	34,16	30	22,80	1035	80x120x75
61,0x61,0 cm 24"x24" (rettificato) (lappato e rettificato)		10 mm	4	1,49	32,30	30	44,70	980	80x120x75
61,0x61,0 cm 24"x24" FP2 (rettificato)		20 mm	2	0,74	32,50	30	22,20	985	80x120x75
61,3x122,6 cm 24"x48" (rettificato)		10 mm	2	1,50	37,80	36	54,00	1145	80x120x75
60,0x121,0 cm 24"x48" (lappato e rettificato)		10 mm	2	1,45	32,92	36	52,20	1200	80x120x75
45,5x45,5 cm 18"x18" (naturale)		9 mm	8	1,66	32,37	44	73,04	1440	80x120x105
45x90 cm 18"x36" (rettificato)		10 mm	3	1,21	26,70	32	38,72	865	100x120x55
45x90 cm 18"x36" (lappato)		10 mm	3	1,21	26,70	32	38,72	865	100x120x55
40x122,6 cm 36"x48" FP2 (rettificato)	<b>NEW</b>								
37,5x75 cm 15"x30" (rettificato)		10 mm	4	1,13	23,30	54	61,02	1280	80x120x90
32,5x32,5 cm 13"x13" mini mosaico (wall - pasta bianca)		10,5 mm	9	1,00	17,20	40	40,00	690	80x120x75
30,8x61,5 cm 12"x24" (naturale)		9 mm	7	1,32	25,65	40	52,80	1040	80x120x75
30,6x30,6 cm 12"x12" sp 11/12 mm - industrial		11/12 mm	11	1,03	26,53	40	39,60	1072	80x120x75
30,6x30,6 cm 12"x12" terre toscane / camelot		9 mm	14	1,31	27,66	60	78,60	1670	80x120x75
30,6x30,6 cm 12"x12" (naturale) shiny marble - victoria - industrial		8,2/8,5 mm	16	1,50	28,39	60	86,40	1774	80x120x75
30,5x122,6 cm 12"x48" (rettificato)		10 mm	4	1,50	31,40	36	54,00	1140	94x120x75
30,4x61,0 cm 12"x24" (rettificato)		9 mm	7	1,30	24,50	40	52,00	990	80x120x75
30,4x30,4 cm 12"x12" (rettificato)		9 mm	13	1,20	24,50	40	48,00	990	80x120x75
30,2x60,8 cm 12"x24" (lappato)		9 mm	7	1,28	25,65	40	51,20	1035	80x120x75
30x30 cm 12"x12" nido d'ape (wall - pasta bianca)		9 mm	11	1,00	15,00	44	44,00	660	80x120x75
25x60 cm 10"x24" (bicottura)		8 mm	10	1,50	19,50	48	72,00	950	80x120x90
22x90 cm 9"x36" (rettificato)		10 mm	5	0,99	21,80	60	59,40	1325	100x120x80
20,3x122,6 cm 8"x48"		10 mm	4	1,00	21,05	48	48,00	1020	80x120x75
20x50 cm 8"x20" (bicottura)		8 mm	14	1,40	18,93	48	67,20	919	80x120x95
20x20 cm 8"x8" gres		7,2 mm	38	1,52	24,40	60	91,20	1475	80x120x100
20x20 cm 8"x8" sp 11/12 mm industrial		11/12 mm	24	0,96	24,70	60	57,60	1490	80x120x100
19,6x160 cm 7"x62" (rettificato)	<b>NEW</b>								
15x90 cm 6"x36" (rettificato)		10 mm	8	1,08	22,00	48	51,84	1066	100x120x80
15,1x30,6 cm 6"x12" (naturale) quarzo / terraforte/ tribeca/meteora		8,5 mm	32	1,48	25,55	60	88,80	1545	80x120x105
15,1x30,6 cm 6"x12" (naturale) terre toscane / camelot / etruria		9 mm	28	1,29	27,18	60	75,60	1641	80x120x105
15x61 cm 6"x24" (rettificato)		9 mm	14	1,28	24,32	50	64,00	1225	80x120x80
10x30 cm 4"x12" (rettificato)		9 mm	26	0,78	14,70	60	46,80	895	80x120x135
7,5x30 cm 3"x12" manhattan (wall - pasta bianca)		8,5 mm	22	0,50	7,45	80	40,00	626	77x117x70
7x61 cm 3"x24" (rettificato) decapé	<b>NEW</b>								
pezzi speciali - special pieces - pièces spéciales - formteile									
6,5x122,6 cm 2"x48" battiscopa (rettificato)			10		12,50	36		465	
6,5x90 cm 3"x36" battiscopa (rettificato)			10		12,90	36		475	
6,5x61,5 cm 3"x24" battiscopa			12		8,50	80		695	
6,5x60,8 cm 3"x24" battiscopa (lappato rettificato)			12		9,20	80		750	
6,5x30,8 cm 3"x12" battiscopa tomahawk			36		13,00	68		900	
7,5x45,5 cm 3"x12" battiscopa			20		12,50	72		915	
7,5x30,6 cm 3"x12" battiscopa			36		13,00	68		900	
6,5x30,6 cm 3"x12" battiscopa			36		13,00	68		900	
6,5x20 cm 3"x8" battiscopa			50		10,50	96		1010	



## CATALOGO GENERALE '18/19

Le informazioni contenute nel presente catalogo sono il più possibile esatte, ma non sono da ritenersi vincolanti. Per esigenze di produzione l'Azienda si riserva il diritto di apportare eventuali modifiche che si rendessero necessarie. Peso, colori e misure sono soggetti alle inevitabili variazioni tipiche del processo di cottura della ceramica. Il colori e gli effetti riportati sul presente catalogo sono indicativi per i limiti consentiti dalla stampa; per questo non possono essere vincolanti e costituire base per eventuali contestazioni.

The information contained in this catalogue is as accurate as possible, but cannot be considered as legally binding. The Company reserves the right to make any modifications that become necessary due to production requirements. Weight, colours and dimensions are subject to the inevitable variations typical of the ceramic firing process. Colours and aesthetic effects shown on this catalogue should be considered indicative and approximate as a result of printing process limits. Possible variations may occur and can not be at the base of any claim.

Les informations reprises dans ce catalogue sont exactes, mais elles n'engagent aucunement notre Société du point de vue légal. Pour des exigences de production la Société se réserve le droit d'apporter toutes les dimensions sont assujettis aux variations typiques du processus de cuisson de la céramiques. Les couleurs et les effets présentés dans ce catalogue sont indicatifs dans la mesure permise par la presse, ce qui explique pourquoi ils ne peuvent pas être obligatoire et constituer la base d'un éventuel désaccord.

Die informationen des vorliegenden Katalogs sind so exakt wie möglich, sind jedoch nicht als gesetzlich verbindlich zu betrachten. Aus Fertigungsgründen behält die Firma sich das Recht vor, eventuell notwendige Änderungen vorzunehmen. Gewicht, Farben und Abmessungen unterliegen den unvermeidlichen Veränderungen, die für den Brennvorgang von Keramikprodukten typisch sind. Die in diesem Katalog gezeigten Farben und Effekte sind Richtwerte, soweit durch die Presse, die ist, warum sie nicht bindend und stellen die Grundlage für eine Meinungsverschiedenheit gestattet.

Marketing:  
Tuscania

Credit:  
**EUREKA!**

stampa:  
Pioppi Industrie Grafiche

finito di stampare:  
Settembre 2018

Note - Notes - Notes - Anmerkungen  
I battiscopa vengono venduti a pz. e a scatola completa. Tutti gli altri pezzi speciali vengono venduti al pezzo. I gradini vengono prodotti solo su ordinazione (tempo minimo di consegna 20 gg lavorativi). Skirtings are sold by piece and full boxes. All other special trims are sold by piece. Steps are produced only on request (minimum delivery terms of 20 days). Les plinthes sont vendues la pièce et par boîte complete. Les autres pieces especiales sont vendus la pièce. Le plat de marche sont produit sur demande (delai minimum de 20 jours). Die Sockelleisten werden pro Stk. und Vollen Kartons verkauft. Stufen und Stufenecken werden nur auf Bestellung produziert (Lieferzeiten mindesten 20 arbeitstagen ab Auftragserteilung).



# CATALOGO GENERALE '18/19

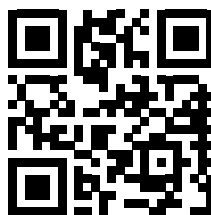

Tuscania S.p.A.  
Via Giardini Sud, 4603  
41028 Serramazzoni (Mo) - Italia  
Tel. +39 0536.952399  
Fax +39 0536.954716  
info@tuscaniagres.it  
www.tuscaniagres.it



Ceramics of Italy